

**WORKS REQUIREMENT
(SECTION VII PART –C)**

**MANAGEMENT STRATEGIES AND
IMPLEMENTATION PLANS (MSIP) TO
MANAGE ESHS RISKS
(ENVIRONMENTAL AND SOCIAL
MANAGEMENT PLAN-ESMP)**

**UPGRADATION OF MANDI REWALSAR
KALKHAR ROAD
IN MANDI DISTRICT
FROM KM 0/000 TO 11/000**

TABLE OF CONTENTS

1.	INTRODUCTION.....	4
1.1	DESCRIPTION OF PROJECT ROAD.....	4
1.2	ASSOCIATED FACILITIES OF TRANCHE I - HPSRTP.....	5
1.3	OBJECTIVES	5
1.4	SCOPE OF ESMP	6
1.5	CONTEXT FOR ESMP.....	6
2.	LEGAL AND REGULATORY FRAMEWORK.....	7
2.1	CLEARANCES AND PERMISSIONS REQUIRED FOR PROJECT ROAD	7
3.	ENVIRONMENTAL AND SOCIAL RISKS AND MITIGATION MEASURES.....	8
3.1	SUMMARY OF RISK/IMPACTS	8
3.2	MITIGATION MEASURES	9
4.	ENVIRONMENT AND SOCIAL MANAGEMENT PLAN	33
4.1	PRE-CONSTRUCTION STAGE ACTIVITIES BY CSC.....	33
4.2	CONSTRUCTION STAGE ACTIVITIES BY THE CONTRACTOR	34
4.3	OPERATION STAGE.....	34
5.	ENVIRONMENTAL MONITORING PROGRAMME	78
5.1	GENERAL.....	78
5.2	PERFORMANCE INDICATORS	78
5.3	MONITORING PLAN FOR ENVIRONMENTAL CONDITIONS	80
5.4	REPORTING SYSTEM.....	84
5.5	INSTITUTIONAL ARRANGEMENTS FOR ESMP IMPLEMENTATION.....	87
5.6	TRAINING AND CAPACITY BUILDING.....	89
5.7	GRIEVANCE REDRESS MECHANISM	89
6.	EMERGENCY RESPONSE PLAN.....	91
6.1	INTRODUCTION	91
6.2	RISK ASSESSMENT	91
7.	ENVIRONMENTAL, SOCIAL, HEALTH AND SAFETY REQUIREMENTS	95
7.1	POLICY ON ENVIRONMENTAL AND SOCIAL ASPECT.....	95
7.2	MINIMUM CONTENT OF ESHS REQUIREMENTS	95
7.3	MINIMUM REQUIREMENTS FOR THE BIDDER'S CODE OF CONDUCT	96
	APPENDIX 1: BORROW AREAS MANAGEMENT PLAN	99
	APPENDIX 2: QUARRY MATERIALS.....	103
	APPENDIX 3: GENERAL GUIDELINES FOR CONTRACTOR'S CONSTRUCTION WATER MANAGEMENT PLAN	105
	APPENDIX 4: SELECTION AND MANAGEMENT OF CONSTRUCTION CAMP	107
	APPENDIX 5: DEBRIS DISPOSAL SITE MANAGEMENT	111
	APPENDIX-6: TRAFFIC AND SAFETY MANAGEMENT DURING CONSTRUCTION.....	114
	APPENDIX 7: FORMATS FOR ENVIRONMENTAL REPORTING	118

APPENDIX 8: NATIONAL STANDARDS OF AIR, NOISE, WATER AND SOIL.....	137
APPENDIX 9: ENVIRONMENT FRIENDLY CONSTRUCTION METHODOLOGY	139
APPENDIX 10: SOIL EROSION AND SEDIMENTATION CONTROL	143
APPENDIX 11: WORKERS SAFETY IN COMMON OPERATION AND DURING CONSTRUCTIONS	145
APPENDIX 12: STORAGE HANDLING, USE AND EMERGENCY RESPONSE FOR HAZARDOUS CHEMICALS.....	158
APPENDIX-13 ENVIRONMENT COMPLIANCE CERTIFICATE.....	162
APPENDIX-14 SEPTIC TANK AND OIL INTERCEPTOR.....	164
APPENDIX 15: MANAGEMENT PLAN FOR LABOUR INFLUX.....	166
APPENDIX-16: GOHP'S STRATEGY TO REHABILITATE AREAS INFESTED WITH INVASIVE ALIEN PLANT SPECIES (EXOTIC WEEDS) IN HIMACHAL PRADESH.....	172
APPENDIX-17: DISASTER MANAGEMENT & EMERGENCY RESPONSE PLAN AT PROJECT ROAD LEVEL.....	180
APPENDIX-18: ILLUSTRATIVE CHECKLIST FOR WORK ZONE SAFETY REQUIREMENTS	211

LIST OF TABLES

TABLE 2-1: CLEARANCES AND PERMISSIONS REQUIRED FOR PROJECT ROAD	7
TABLE 3-1: ENVIRONMENTAL AND SOCIAL RISKS/IMPACTS	8
TABLE 3-2: PROVISION FOR EROSION CONTROL MEASURES FOR PROJECT ROAD.....	9
TABLE 3-3: POTENTIAL LOCATIONS FOR BIO ENGINEERING INTERVENTIONS ALONG PROJECT ROAD	14
TABLE 3-4: BIO-ENGINEERING INTERVENTIONS FOR SLOPE STABILITY AND EROSION CONTROL	14
TABLE 3-5: PROVISION FOR LONGITUDINAL DRAINS ALONG PROJECT ROAD.....	15
TABLE 3-6: PROPOSED CROSS DRAINAGE STRUCTURES UNDER HPSRTP	16
TABLE 3-7: PROPOSED CROSS DRAINAGE STRUCTURES UNDER HPSRTP	17
TABLE 3-8: DETAILS OF BUS STOPS/RAIN SHELTERS ALONG PROJECT ROAD.....	18
TABLE 3-9: ROAD SAFETY SIGNAGES PROPOSED TO PROJECT ROAD	19
TABLE 3-10: STRUCTURES CONSIDERED FOR CONSERVATION/RENOVATION AND ENHANCEMENT MEASURES	20
TABLE 4-1: ENVIRONMENT AND SOCIAL MANAGEMENT PLAN ó ENVIRONMENTAL IMPACTS	35
TABLE 5-1: PERFORMANCE INDICATORS.....	79
TABLE 5-2: ENVIRONMENTAL MONITORING PLAN FOR AIR, WATER, NOISE AND SOIL	82
TABLE 5-3: REPORTING SYSTEM	85
TABLE 5-4: SUMMARY DETAILS OF REPORTING FORMATS	85
TABLE 5-5: CONTACT DETAILS FOR LODGING GRIEVANCES AND FEEDBACK UNDER HPSRTP	89
TABLE 6-1: RISK ASSESSMENT MATRIX	91
TABLE 6-2: POTENTIAL RISKS ASSOCIATED WITH DIFFERENT TYPES OF HAZARDS	92
TABLE 6-3: CONTROLLED MEASURES FOR /IDENTIFIED RISKS:	92
TABLE 6-4: DISPLAY BOARD WITH EMERGENCY CONTACT NUMBERS:	94

1. INTRODUCTION

1.1 Description of Project Road

1. The Mandi to Rewalsar- Kalkhar road is 28+000 Km and is designated as MDR-26 (Major District Road). The project road starts from Mandi town and ends at Kalkhar and traverses entirely within Mandi Tehsil of Mandi district. Project road connects to NH -154 at 0 km, NH-3 at Km 4.5 (Talyahar) and MDR 84/old SH 32 at Km 29 (Figure 1-1). The latitude and longitude of the project road at Mandi and Kalkhar are 31.707°N to 31.632°N and 76.930°E to 76.833°E respectively. The altitude of project corridor from Mandi to Kalkhar ranges between 850-1350 m above mean sea level (MSL).

2. There are 26 settlements along the project road. Some of the big settlement areas along the project road are Mandi, Panjethi, Talyahar, Ghera, Gaddel, Rattipul, Raghwanoo, Randhara, Gambharpul, Rewalsar, Kalkhar. Out of the total 28 km length, the built-up areas of the settlements extend to 9 km, which is about 32% of the road length. There are 18 junctions along the project road out of which 2 are major junctions and the rest 16 are minor junctions. The existing carriageway width varies from 3.1m to 7.2m all along the project road.

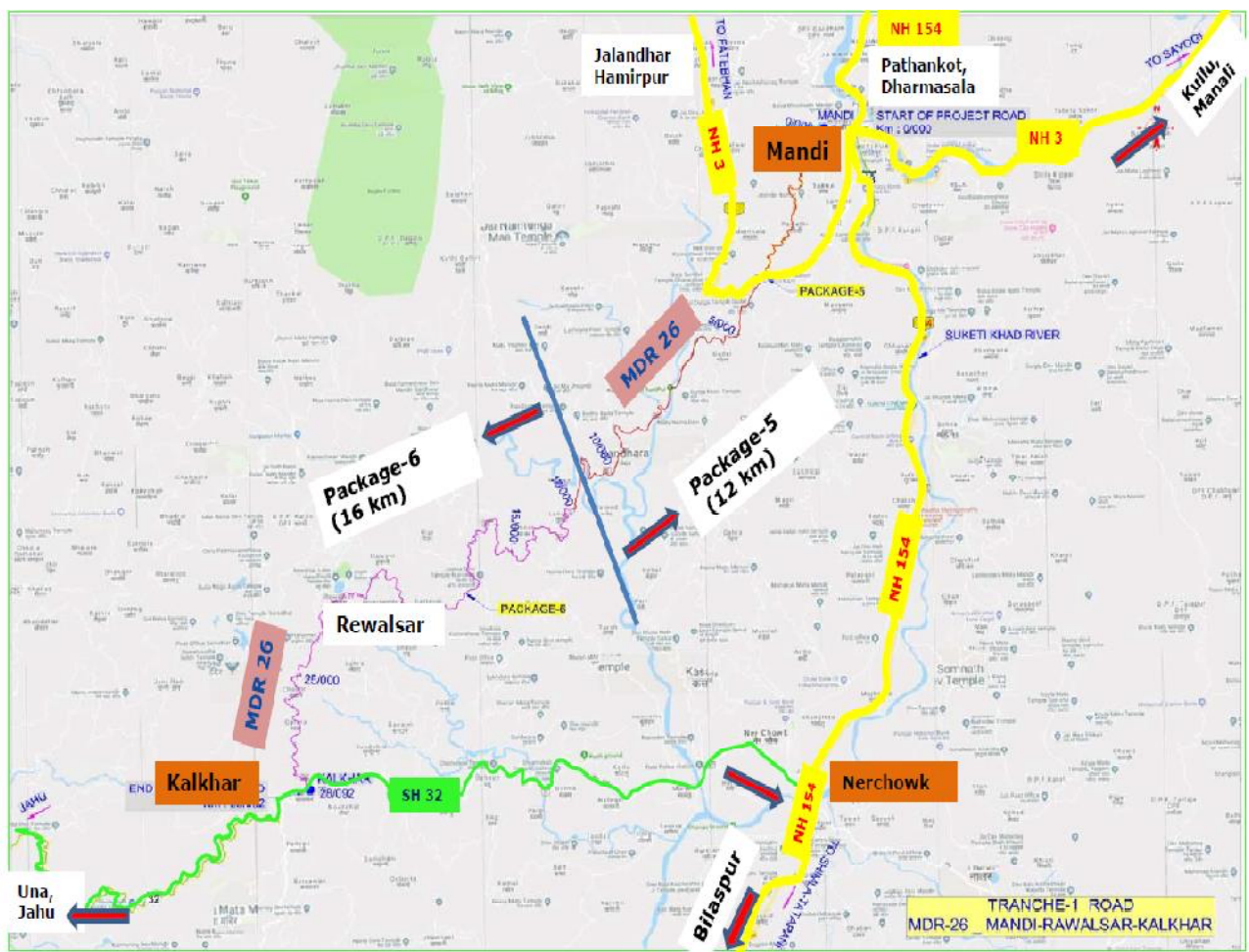

Figure 1-1: Location Map of Mandi -Rewalsar- Kalkhar Project Road

1.2 Associated Facilities of Tranche I - HPSRTP

3. At present four bridges (3 minor and 1 major bridge) are under construction at different chainages along the 28 km long Mandi-Rewalsar-Kalkhar road by HPPWD and funded through the Central Road Fund (CRF) of Government of India (GoI). The Mandi Rewalsar Kalkhar is one of the four corridors under Tranche I and the four bridges, which are under construction meets all the three criteria set out in the ESF Policy of the World Bank to qualify as Associated Facilities

4. Since the qualifying Associated Facilities, mentioned above is not under the funding by any other multi-lateral or bi-lateral funding agencies, requirement for a common approach for the assessment and management of environmental/social risks and impacts will not apply. Further, the ESF policy stipulate that the qualifying Associated Facilities shall meet the ESSs requirements, to the extent that the borrower (HPRIDCL) has control over such Associated Facilities.

5. In present case, HPRIDCL has no direct control over the qualifying Associated Facilities i.e., four bridges under construction by HPPWD. Although, HPRIDCL resolve itself to undertake certain passive mitigation measures, if any warranted at all the 4 bridge locations, since these bridges are integral to the Mandi-Rewalsar-Kalkhar corridor. Such mitigation measures can comprise river/stream bed clean up and profile restoration (up to 500 meters on both upstream and down steam sides), riverbank protection works through both engineering and nature-based bio-engineering solutions (up to 100 meters on both upstream and down steam side) and road safety measures. However, HPRIDCL has no jurisdictional control over the discharge of untreated sewage/sullage directly into river/steam(s) and dumping of construction debris and/or municipal waste into river/streams by the local community from the nearby settlement areas, shops and establishments at all locations.

1.3 Objectives

6. The main objective of Environment and Social Management Plan is to mitigate the various adverse impacts and enhance positive impacts of the project road. The objectives at various stages of the project planning, design and implementation stages are as follows.

Design Phase

- To address the preconstruction adverse social impacts such as impacts on private assets ó residential, commercial structures etc.,and CPRs through commensurate mitigation measures.
- To minimize impact on roadside trees and vegetation cover.
- To incorporate safety of road users and roadside communities in project design.
- To provide mitigation measures to all anticipated environmental degradation.
- To develop a design that incorporate environmental safeguards.

Construction Stage

- To prevent and reduce the negative environmental impacts of the project by implementing the mitigation measures to be carried out by the contractor.
- To ensure that the provision of the ESMP (Environment & Social Management Plan) are strictly followed and implemented by strengthening implementation arrangement.
- To address the construction stage social impacts arising due to various project activities enroute the corridor and particularly at habitations through specific measures that need to be applied across and certain specific measures that shall be determined on a case by case basis.

Operation Stage

- To monitor deterioration of natural environmental components of air, water, soil and noise, etc.
- To improve the safety of road users and the roadside communities.

1.4 Scope of ESMP

7. Environment and Social Management Plan (ESMP) consists of the set of mitigation, monitoring and institutional measures to be taken during the design, construction and operation phase of the project road to eliminate adverse social and environmental impacts, to compensate them, offset them, or to reduce them to acceptable levels in accordance with the mitigation hierarchy. The plan also includes the actions needed for the implementation of these measures.

1.5 Context for ESMP

8. This Environmental & Social Management Plan for Mandi- Rewalsar- Kalkhar road is based on the findings of ESIA (Environmental and social Impact Assessment) carried out in the project corridor and provides for effective implementation of the Environment & Social Management measures required for addressing the potential environmental & Social impacts/risks. This Environment & Social Management Plan assists HPRIDCL and the Contractor to implement the environmental & Social management measures effectively.

2. LEGAL AND REGULATORY FRAMEWORK

9. A review of the legal and regulatory framework related to the environmental and social safeguards and their applicability to the project road has been made covering the following and included under Section 3 of ESIA Volume:

- Applicable Regulations of GoI/ GoHP
- World Bank ESF Policy, WBG's EHSGs and Standards ó Extent of Relevance
- Comparison of GoI/ GoHP legislations and ESF, 2016

10. The ESIA volume may be referred for any further details on the applicable legal and regulatory framework for the project road.

2.1 Clearances and Permissions required for Project Road

11. The project road does not require any prior environmental or forest clearances from the State Government or Government of India level. The pre-construction and construction stage permissions required for the project road are given in **Table 2-1**.

Table 2-1: Clearances and Permissions Required for Project Road

S. No.	Clearances/Permissions required	Competent Authority to Accord Clearances	Responsibility to Obtain Clearance
A. Pre-construction Stage			
1	Permission for felling of an estimated 360 trees, which are within the Right of Way (RoW)/ Corridor of Impact (CoI)	Divisional Forest officer, Mandi, Department of Forests, GoHP and District Magistrate Mandi	HPRIDCL
B. Construction Stage			
1	Consent to establish and Consent to operate construction camp sites, crusher units, hot mix plants, concrete batch mix plants, WMM plants, work force camps etc.	Himachal Pradesh State Pollution Control Board	Contractor
2	Permissions for sourcing of water for construction activities (Surface and Ground Water)	HP Ground Water Authority and Irrigation and Public Health Department, GoHP	Contractor
3	License to store HSD and Explosives at Construction camp, if required.	Regional office of Chief Controller of Explosives, GoI, Himachal Pradesh	Contractor
4	Permission to Establish Construction camps	District Magistrate & Local Panchayat (s), landowners in case of private land	Contractor
5	Opening of new quarry sites for Stone aggregates	Geological Wing, Department of Industries, GoHP	Contractor
6	Labour licence/ permits for engaging construction workers (skilled & un-skilled)	Respective district level Labour Officer	Contractor

3. ENVIRONMENTAL AND SOCIAL RISKS AND MITIGATION MEASURES

3.1 Summary of Risk/Impacts

12. Identification of Environmental and social Risks/Impacts was carried during ESIA process is summarized as follows in Table 3-1.

Table 3-1: Environmental and Social Risks/Impacts

Components	Environmental and social Risks	Risk Type
Construction Phase		
Topography & Geology	<ul style="list-style-type: none"> Change in existing profile of the land due to earthwork and rock excavation. Disturbance on geological setting due to hill side cutting/quarrying resulting in the accumulation of debris material. 	Low risk
Soil	<ul style="list-style-type: none"> Loosening of topsoil & loss of vegetative cover along the road due to excavation and back filling which will lead to enhanced soil erosion. 	Low risk
Land Use	<ul style="list-style-type: none"> Generation of debris waste in the form of excavated material/construction spoils from construction sites. Changes in existing land use pattern of the ROW for construction of the road. Roadside agricultural land will be affected by unauthorised debris disposal. 	Moderate risk
Drainage	<ul style="list-style-type: none"> Chances of filling of existing drainage courses during earth filling. Scouring of land in the outfall locations of culverts. 	Moderate risk
Water Use	<ul style="list-style-type: none"> Impact on the local water sources due to its usage as construction water. 	Low risk
Water Quality	<ul style="list-style-type: none"> Increase of sediment load in the runoff from construction sites and increase in turbidity in receiving streams/water bodies. Water pollution due to sewage from construction camps. 	Moderate risk
Air Quality	<ul style="list-style-type: none"> Deterioration of air quality due to fugitive dust emission from construction activities like excavation, backfilling & concreting, hauling & dumping of earth materials & construction spoils, and vehicular movement along unpaved roads. Deterioration of air quality due to gaseous emissions from construction activities. 	Moderate risk
Noise Level	<ul style="list-style-type: none"> Increase in noise level due to construction activities like operation of construction equipment and vehicular traffic. 	Moderate risk
Flora and Fauna	<ul style="list-style-type: none"> Loss of flora & loss of habitat of fauna due to felling of trees along the ROW. 	Low risk
Construction Camp	<ul style="list-style-type: none"> Influx of construction work force and supplier who are likely to construct temporary sheds in the vicinity. Likely sanitation and health hazards & other impacts on the surrounding environment due to inflow of construction labourers. Health risks due to lack of health and sanitation conditions through disposal of sewage on open land which may cause mosquito nuisance, water borne diseases etc. Chances of spread of sexually transmittable 	Moderate risk

Components	Environmental and social Risks	Risk Type
	diseases like AIDs.	
Occupational Health & Safety	<ul style="list-style-type: none"> Health & safety related problems to construction workers due to inadequate health & safety measures. 	Moderate risk
Road Safety	<ul style="list-style-type: none"> Increase on incidence of road accidents due to disruptions caused in existing traffic movements. 	Moderate risk
Land Acquisition	<ul style="list-style-type: none"> Design Measures suggests that there is no land acquisition from private parties 	Low Risk
Private structures	<ul style="list-style-type: none"> Encroachment of structures will be adequately compensated as per RAP. A RAP will be prepared to mitigate the measures. No displacement will take place due to removal of structures; the impacts are partial. 	Moderate risk
Operational Phase		
Land Use & Encroachment	<ul style="list-style-type: none"> Change of land use by squatter/ encroachment within ROW and induced development outside the ROW. New spaces generated due to shift in alignment could be encroached by local people or other people. 	Moderate risk
Drainage	<ul style="list-style-type: none"> Environment degradation is due to improper maintenance of drainage. 	Moderate risk
Air Quality	<ul style="list-style-type: none"> Air pollution due to vehicular emission from road traffic. 	Low risk
Noise Level	<ul style="list-style-type: none"> Noise pollution due to increased traffic. 	Low risk
Access	<ul style="list-style-type: none"> Significant severance problem on pedestrian & animal crossing and cross traffic due to widening, partially access control & increase in traffic speed. 	Low risk
Road Safety	<ul style="list-style-type: none"> Impacts on human health due to accidents. Damage of road due to wear and tear. 	Low risk

3.2 Mitigation Measures

13. To address above risks, mitigation measures have been proposed and have been included in various design proposals (as described below) and site-specific enhancement or management plans. These are;

3.2.1 Design Proposals

Provision of Protection Measures

14. Based on the designed alignment and topographic survey results, the location, where the normal fill slopes cannot be used due to the topographic conditions, retaining walls and Breast walls are provided. The locations of such proposed protection measures are provided in Table 3-2.

Table 3-2: Provision for Erosion Control Measures for Project Road

a) Breast Wall towards Hill Side

<i>Sl No</i>	<i>From</i>	<i>To</i>	<i>Length</i>	<i>Hts</i>	<i>Side</i>
1	2055	2120	65	1.5	RHS
2	2135	2175	40	4	RHS
3	2205	2250	45	4	RHS
4	2300	2320	20	2	RHS
5	2320	2350	30	1.5	RHS
6	2355	2375	20	1.5	RHS
7	2420	2460	40	2	RHS
8	2460	2490	30	1.5	RHS
9	2490	2530	40	2	RHS
10	2530	2550	20	1.5	RHS
11	2810	2835	25	1.5	RHS
12	2880	2915	35	1.5	RHS
13	2990	3010	20	1.5	RHS
14	3050	3130	80	2.5	RHS
15	3170	3200	30	3	RHS
16	3200	3300	100	3	RHS
17	3300	3310	10	3	RHS
18	3310	3360	50	1.5	RHS
19	3360	3410	50	3	RHS
20	3415	3420	5	3	RHS
21	3420	3490	70	3	RHS
22	3510	3600	90	3	RHS
23	3600	3670	70	3	RHS
24	3705	3730	25	3	RHS
25	3780	3850	70	3	RHS
26	3880	3960	80	2	RHS
27	3960	3970	10	3	RHS
28	3975	3980	5	3	RHS
29	3980	4150	170	3	RHS
30	4150	4200	50	1.5	RHS
31	4700	4705	5	2	RHS
32	4705	4860	155	2	RHS
33	4860	4870	10	2	RHS
34	4870	4900	30	2	RHS
35	4900	4925	25	2	RHS
36	4925	5035	110	2	RHS
37	5035	5100	65	2	RHS
38	5100	5200	100	2	RHS
39	5200	5280	80	1.5	RHS
40	5300	5325	25	3	RHS
41	5330	5380	50	3	RHS

42	5470	5530	60	1.5	RHS
43	5530	5580	50	4	LHS
44	5580	5635	55	4	LHS
45	5635	5660	25	3	LHS
46	5660	5700	40	1.5	LHS
47	5760	5820	60	1.5	LHS
48	5880	5935	55	4	LHS
49	5935	6020	85	3	LHS
50	6020	6030	10	3	LHS
51	6030	6055	25	1.5	LHS
52	6055	6080	25	3	LHS
53	6155	6210	55	4	LHS
54	6210	6250	40	4	LHS
55	6250	6280	30	4	LHS
56	6280	6290	10	4	LHS
57	6290	6320	30	4	LHS
58	6530	6565	35	1.5	LHS
59	6620	6640	20	1.5	LHS
60	6650	6680	30	1.5	LHS
61	6720	6760	40	3	LHS
62	6790	6830	40	2.5	LHS
63	6900	6940	40	2.5	LHS
64	6940	6970	30	4	LHS
65	6970	6980	10	4	LHS
66	6980	7070	90	4	LHS
67	7530	7570	40	1.5	RHS
68	7570	7600	30	1.5	RHS
69	7600	7610	10	3	RHS
70	7610	7660	50	3	RHS
71	7660	7780	120	3	RHS
72	7800	7810	10	1.5	RHS
73	7890	8000	110	2	RHS
74	8000	8090	90	2	RHS
75	8090	8160	70	4	RHS
76	8160	8210	50	2.5	RHS
77	8210	8240	30	2.5	RHS
78	8240	8280	40	2	RHS
79	8280	8300	20	2	RHS
80	8300	8330	30	2	RHS
81	8330	8410	80	2	RHS
82	8410	8420	10	2	RHS
83	8420	8505	85	2	RHS

84	8505	8530	25	2	RHS
85	8530	8570	40	2	RHS
86	8570	8620	50	2	RHS
87	8620	8690	70	3	RHS
88	8690	8720	30	1.5	RHS
89	8740	8790	50	3	RHS
90	8790	8820	30	1.5	RHS
91	8820	8880	60	3	RHS
92	8880	8910	30	3	RHS
93	8910	8940	30	3	RHS
94	9040	9080	40	1.5	RHS
95	9110	9145	35	3	RHS
96	9150	9230	80	1.5	RHS
97	9230	9245	15	3	RHS
98	9245	9300	55	3	RHS
99	9300	9335	35	3	RHS
100	9335	9370	35	3	RHS
101	9400	9410	10	1.5	RHS
102	9410	9470	60	1.5	RHS
103	9510	9575	65	3	RHS
104	9590	9620	30	1.5	RHS
105	9730	9790	60	1.5	RHS
106	9840	9930	90	1.5	RHS
107	9930	9965	35	5	RHS
108	10130	10160	30	1.5	RHS
109	10460	10495	35	5	RHS
110	10495	10560	65	5	RHS
111	10560	10625	65	2.5	RHS
112	10625	10650	25	1.5	RHS
113	10650	10675	25	1.5	RHS
114	10675	10830	155	2.5	RHS

b. Retaining /Toe wall adjacent to Shoulders towards Valley Side

S.No	Design Ch From	Design Ch To	Length (m)	Avg Height	Side
1	2160	2260	100	2	LHS
2	2540	2640	100	1.5	LHS
3	2670	2780	110	1.5	LHS
4	3480	3520	40	1	LHS
5	3960	4000	40	1	LHS
6	5630	5670	40	1.5	RHS

7	5670	5710	40	1.5	RHS
8	5770	5920	150	1.5	RHS
9	6080	6100	20	1	RHS
10	6150	6300	150	1	RHS
11	6830	6970	140	1	RHS
12	6970	7000	30	1	RHS
13	8140	8180	40	2	LHS
14	8260	8280	20	2	LHS
15	8920	8940	20	2.5	LHS
16	8960	9030	70	2.5	LHS
17	9060	9240	180	2.5	LHS
18	10070	10190	120	1	LHS
19	10290	10310	20	1	LHS
20	10350	10390	40	1	LHS
21	10660	10710	50	1	LHS
Total			1520		

C. Gabion Walls Provided at Toe side

S.No	Design Ch from	Design To	Length	Average Height	Side
1	2640	2670	30	2	LHS
2	6100	6150	50	2	RHS
3	9030	9060	30	2	LHS
4	9280	9310	30	2	LHS
5	10190	10250	60	2	LHS
6	10250	10290	40	3	LHS
7	10310	10350	40	3	LHS
8	10470	10510	40	2	LHS
9	10800	10860	60	2	LHS
10	10860	11000	142	3	LHS
Total			520		

Provision for Nature Based Bio Engineering Interventions

15. The landslide impact can be further minimized / mitigated through provision of engineering and non-engineering interventions. Some of engineering measures considered for the project road are breast walls along hill side and retaining walls along valley side in order to protect the vulnerable and potential landslide locations due to hill cut and filling of valley side for project road construction.

16. The landslide impact can be further minimized / mitigated through provision of non-engineering and nature-based bio engineering interventions. Potential locations for nature-based bio-engineering intervention requirements assessed for the project road during ESIA is given in **Table 3-3**. However, these locations will have to re-assessed/reviewed along with additional warranted

locations for bio- engineering interventions once the hill cut operations along hill side and filling works along valley side are completed during construction phase.

Table 3-3: Potential Locations for Bio Engineering interventions along Project Road

S. No.	Chainage	Bio-engineering Intervention	LHS/RHS	Length RM	Slope length (m)	Slope angle°
1	1+760	Hedge Brush Layer, Grass Slip Plantation	LHS/HS	25	8	50°
2	1+960	Hydroseeding	RHS/HS	300	6	>60°
3	2+580	Hedge Brush Layer, Grass Slip Plantation	RHS/HS	420	8	55°
4	3+350	Grass Slip Plantation	RHS/HS	8	8	45°
5	3+350	Grass Slip Plantation	LHS/VS	8	8	45°
6	3+490 to 3+800	Brush Layer, Grass Slip Plantation and Bamboo Crib Wall	RHS/HS	310	8	45°
7	5+480 to 5+530	Brush Layer, Grass Slip Plantation and Bamboo Crib Wall	LHS/HS	50	8	45°
8	5+480	Brush Layer, Grass Slip Plantation and Bamboo Crib Wall	RHS/VS	20	15	45°
9	9+430 to 9+460	Brush Layer, Grass Slip Plantation and Bamboo Crib Wall	RHS/HS	30	8	45°
10	10+200 to 11+200	Brush Layer, Grass Slip Plantation	RHS/HS	1,000	6	45°

17. Most suitable provisions made for the nature based (bio-engineering) interventions considered in the project design are given in **Table 3-4** and cover potential landslide and erosion prone stretches along the RoW, upstream and downstream of seasonal streams, CD structures, muck/debris disposal sites, low-lying areas reclaimed /open areas in RoW, areas of cleared of invasive vegetation among others.

18. Adequate cost provisions have been included in the project cost estimates for both engineering and non-engineering interventions to avoid impacts due to landslides, erosion and enhance vegetative cover along project road. The bio-engineering works are to be executed in accordance with the detailed specifications of Bio-Engineering manual of HPPWD under the supervision of bio-engineering specialist of HPRIDCL.

Table 3-4: Bio-Engineering Interventions for Slope Stability and Erosion Control

S. No	Description	Unit	Quantity Pkg 5
1	Construction of hedge brush layer	RM	15550
2	Construction of brush layer	RM	15150
3	Construction of live palisade	RM	600
4	Construction of live Fascine	RM	1100
5	Grass slip plantation on slope <45° @ 100 drills/sqm	sqm	3400
6	Grass slip plantation on slope 45°-60° @ 100 drills/sqm	sqm	1300
7	Grass slip plantation on >60° slope @ 100 drills/sqm	sqm	500
8	Plantation of large sized stature grass slips at slope of <45° @ 20 slips/sqm	sqm	3000

9	Bamboo crib wall	cum	600
10	Tree plantation in plains within RoW	nos	1300
11	Shrub Plantation in plains Within Row	Nos.	570
12	Agave plantation in slopes	nos	80
13	Group plantation of shrubs	sqm	80
14	Hedge Plantation (2 plants/RM)	RM	200
15	Hedge Plantation (4 plants/RM)	RM	200
16	Bamboo plantation within RoW	nos	200
17	Grass seed sowing at >40°slopes including vetiver	sqm	12300
18	Grass seed sowing<40° slopes	sqm	12400
19	Grass seed sowing on slope 40-45 with mulch and jute netting	sqm	11300
20	Hydro seeding including dressing/trimming of slope including removing of fractured material and maintenance with watering 2 to 3 times after 12hrs of hydro seeding @ 1 litre/Sqm (each time) for six months/propagation of grasses and shrubs under supervision of hydro seeding provider	sqm	14050

Provision of Longitudinal Drains along Project Road

19. In order to ease the drainage along the project road, based on topography and rainfall, two types of surface drains have been proposed for the project road as shown in given in Table 3-5. These are;

20. **V-Shaped Drain:** This drain is provided normally in the cut slopes located in hilly and rolling terrain, this drain is of lined in nature. Predominant lengths in hilly areas are provided with this drain type.

21. **Rectangular Drain:** For the locations, such as built-up areas and those with pedestrian movements rectangular drains have been proposed. As per the requirement, it is provided on one side or both sides of the project road.

Table 3-5: Provision for Longitudinal Drains along Project Road

Sl. No	Des Ch From	Des Ch To	Design Length (m)	Type of Drain	Side	TCS Type
1	0	350	350	Rectangular in Built up	RHS	TCS-1
2	350	1700	1350	Rectangular in Built up	RHS	TCS-1 A
3	1700	2100	400	Rectangular in Built up	Both sides	TCS-4

Sl. No	Des Ch From	Des Ch To	Design Length (m)	Type of Drain	Side	TCS Type
4	2100	2850	750	V Drain	RHS	TCS-5
5	2850	3350	500	Rectangular in Built up	Both sides	TCS-4
6	3350	4190	840	V Drain	RHS	TCS-5
7	4190	4370	180	Rectangular in Built up	Both sides	TCS-4
8	4370	5590	1220	Rectangular in Built up	Both sides	TCS-2
9	5590	6300	710	V Drain	RHS	TCS-3
10	6300	6750	450	Rectangular in Built up	Both sides	TCS-2
11	6750	7060	310	V Drain	RHS	TCS-3
12	7060	7540	480	Rectangular in Built up	Both sides	TCS-2
13	7540	7920	380	V Drain	RHS	TCS-3
14	7920	8100	180	Rectangular in Built up	Both sides	TCS-2
15	8100	8280	180	V Drain	RHS	TCS-3
16	8280	8850	570	Rectangular in Built up	Both sides	TCS-2
17	8850	9330	480	V Drain	RHS	TCS-3
18	9330	9990	660	Rectangular in Built up	Both sides	TCS-2
19	9990	11000	1010	V Drain	RHS	TCS-3
Total			11000			

Provision of Cross drainage structures along Project Road

22. As a part of Project road up gradation, 55 CD structures are being reconstructed, 34 are new construction, 5 are retained with minor repairs and extension. The list of the proposed cross drainage works is given in below Table 3-6 & Table 3-7. The chainage wise details of cross drainage structures are provided in Appendix-6 of ESIA report.

Table 3-6: Proposed Cross Drainage Structures under HPSRTP

Type	Reconstruction	New Construction	Retaining	Widening	Total
Box Culverts	9	3	0	0	12
Pipe Culverts	24	7	2	0	33
Slab Culverts	0	0	3	1	04
Major Bridges	0	1	0	0	1
Minor Bridges	1	3	0	1	5

Provision of Cross Drainage structure

23. Surface drains are further connected to culverts so that water can be channelized down the valley. Erosion control measures in the form of step apron have been provided at the outlet of the culvert. schedule of the culvert is provided in table 3-7 below

Table 3-7: Proposed Cross Drainage Structures under HPSRTP

S. No.	Existing Chainage (Km)	Design Chainage (Km)	Existing Structure Type	Existing Span Arrangement		Improvement Proposal	Proposed str Type	Proposed Span Arrangement	
				No. of Spans	Span			No. of Spans	Span
1	0+668	0+668	pipe	1	0.90	Retained	Pipe Culvert	1	0.90
2	1+275	1+274	Slab	1	5	Retained	Slab Culvert	1	5.00
3	1+450	1+451	Slab	1	2.6	Retained	Slab Culvert	1	2.60
4	1+850	1+849	MNB	1	6.2	Reconstruction	Minor Bridge	1	7.50
5	2+250	2+240	Slab	1	0.8	Reconstruction	Box Culvert	1	2.00
6	2+310	2+298	pipe	1	0.9	Reconstruction	Pipe Culvert	1	1.00
7	New	2+526				New Construction	Box Culvert	1	2.00
8	2+820	2+814	Slab	1	1.7	Reconstruction	Box Culvert	1	2.00
9	New	2+850				New Construction	Box Culvert	1	2.00
10	3+090	3+088	Slab	1	0.7	Reconstruction	Box Culvert	1	2.00
11	3+370	3+351	pipe	1	0.90	Reconstruction	Pipe Culvert	1	1.00
12	3+390	3+381	Slab	1	2	Widening	Slab Culvert	1	2.00
13	3+720	3+705	Slab	1	1.7	Reconstruction	Box Culvert	1	2.00
14	4+000	3+983	Slab	1	1.20	Reconstruction	Box Culvert	1	2.00
15	4+550	4+532	pipe	1	0.9	Reconstruction	Pipe Culvert	1	1.00
16	4+850	4+827	Slab	1	4	Reconstruction	Box Culvert	1	4.00
17	5+000	4+959	Slab	1	4.2	Retained	Slab Culvert	1	4.20
18	New	5+201				New Construction	Pipe Culvert	1	1.00
19	5+820	5+719	MNB	1	17.20	Under Construction	Minor Bridge	1	19.75
20	6+020	5+881	pipe	1	0.60	Reconstruction	Pipe Culvert	1	1.00
21	6+240	6+068	pipe	1	0.9	Reconstruction	Pipe Culvert	1	1.00
22	6+300	6+162	pipe	1	0.9	Reconstruction	Pipe Culvert	1	1.00
23	6+440	6+295	pipe	1	0.9	Reconstruction	Pipe Culvert	1	1.00
24	6+550	6+406	pipe	1	0.9	Reconstruction	Pipe Culvert	1	1.00
25	6+745	6+597	Slab	1	1.20	Reconstruction	Box Culvert	1	2.00
26	6+960	6+813	pipe	1	0.90	Reconstruction	Pipe Culvert	1	1.00
27	New	6+943	-	-	-	New Construction	Pipe Culvert	1	1.00
28	7+120	6+970	pipe	1	0.90	Reconstruction	Pipe Culvert	1	1.00
29	7+530	7+365	MNB	1	40.4	Under Construction	Major Bridge	1 / 1	45 / 28
30	7+775	7+593	pipe	1	0.90	Reconstruction	Pipe Culvert	1	1.00
31	8+120	7+842	Slab	1	2.00	Under Construction	Minor Bridge	1	24.00
32	8+440	8+070	pipe	1	0.90	Reconstruction	Pipe Culvert	1	1.00
33	8+820	8+444	pipe	2	0.90	Reconstruction	Pipe Culvert	1	1.00

S. No.	Existing Chainage (Km)	Design Chainage (Km)	Existing Structure Type	Existing Span Arrangement		Improvement Proposal	Proposed str Type	Proposed Span Arrangement	
				No. of Spans	Span			No. of Spans	Span
34	8+860	8+492	pipe	1	0.90	Reconstruction	Pipe Culvert	1	1.00
35	8+920	8+547	pipe	1	0.90	Reconstruction	Pipe Culvert	1	1.00
36	9+090	8+713	pipe	1	0.90	Reconstruction	Pipe Culvert	1	1.00
37	9+325	8+948	MNB	1	21.30	Widening	Minor Bridge	1	21.30
38	9+340	9+003	Slab	1	1.20	Reconstruction	Box Culvert	1	2.00
39	9+470	9+085	Slab	1	0.70	Reconstruction	Box Culvert	1	2.00
40	9+680	9+307	pipe	1	0.90	Reconstruction	Pipe Culvert	1	1.00
41	9+780	9+400	pipe	1	0.90	Retained	Pipe Culvert	1	0.90
42	10+050	9+670	pipe	1	0.90	Reconstruction	Pipe Culvert	1	1.00
43	New	10+045				New Construction	Pipe Culvert	1	1.00
44	New	10+245				New Construction	Pipe Culvert	1	1.00
45	New	10+313				New Construction	Pipe Culvert	1	1.00
46	10+800	10+405	pipe	1	0.90	Reconstruction	Pipe Culvert	1	1.00
47	New	10+635				New Construction	Pipe Culvert	1	1.00
48	11+100	10+706	pipe	1	0.90	Reconstruction	Pipe Culvert	1	1.00
49	11+225	10+826	pipe	1	0.90	Reconstruction	Pipe Culvert	1	1.00
50	11+270	10+879	pipe	1	0.90	Reconstruction	Pipe Culvert	1	1.00
51	New	10+966				New Construction	Pipe Culvert	1	1.00
52	11+475	11+054	MNB	1	41.00	Under Construction	Minor Bridge	1	55.00
53	11+753	11+330	pipe	1	1.00	Reconstruction	Pipe Culvert	1	1.00
54	12+200	11+778	pipe	1	0.90	Reconstruction	Pipe Culvert	1	1.00
55	New	11+821				New Construction	Box Culvert	1	2.00

Bus Stops/ Rain Shelters

24. The project road has 4 existing bus stops between at 1/205 to 9/490 and 5 no New bus stops has been proposed. The details are given in the table 3-8 below. Under the project road widening proposal, 3 bus stops/rain shelters is retained, 5 are newly proposed and 1 no. Bus Stop is reconstructed, details are as shown in Table 3-8. All the bus stops are to be provided with proper cross ventilation as well as arrangement to prevent entry of stray animals into the bus stop. All re-modeled bus stops shall have universal access (ramp) for physically challenged persons in accordance with rights of persons with disabilities act, 2016. Provisions for bio-toilets at selected bus stops has been considered and but same could not be considered due to requirement of regular maintenance issues and responsibility thereof during operational stage despite this issue was requirement from the local people during the consultations.

Table 3-8: Details of Bus stops/Rain Shelters along Project Road

S. No	Existing Chainage	Design Chainage	Side	Condition	Remarks
1	1/535	1+530	LHS	Poor	Reconstruction
2	2/195	2+185	RHS	New	New proposal

S. No	Existing Chainage	Design Chainage	Side	Condition	Remarks
3	3/190	3+180	LHS	New	New proposal
4	4/210	4+190	LHS	Fair	Retained
5	5/400	5+350	LHS	New	New proposal
6	6/570	6+420	RHS	New	New proposal
7	7/475	7+320	RHS	Fair	Retained
8	9/845	9+460	RHS	Fair	Retained
9	11/345	10+945	RHS	New	New proposal

Road Safety Measures:

25. The built-up and settlement areas have direct access on to project road in addition to intersections like major and minor junctions. The road will also act as haul road for transporting construction materials and debris, along with concurrently ongoing construction activities at prioritized stretches. Adding to these, existing site settings i.e., present narrow roadway width, sharp curves, hilly/mountainous terrain will provide limited option for maneuvering. All of these is likely to cause restrictions/inconveniences and safety issues to existing road users, requiring temporary traffic diversions, traffic management through warden/monitor(s) with reflective jackets and handheld batons and appropriate traffic signages in addition to dust suppression and noise level management measures, among others.

26. To ensure ease of traffic movement as well as community safety (local people as well throughfare road users) along the road will largely depend on contractor's work management plan and procedures, which will be regulated through contractual obligations. In addition, road safety measures like provision of information/caution boards, road signages, object markers will be provided at all required locations in accordance with IRC:99-2019 as per the road safety plan for the project road and are summarized in **Table 3-9**.

Table 3-9: Road Safety Signages proposed to Project Road

S.No	Description	Locations / Usage	Unit	Quantities
A	Informatory signs			
	a) Facility information Signs of size 800mm x 600mm	Bus stops & Hospitals	Nos	13
	b) Direction / Place Identification signs of 1200mm x 600mm	Settlements and Minor Junctions	Nos	24
	c) Advance Direction / Destination / Reassurance / Place Identification signs of 1200mm x 750mm	Minor Junc. - 4 legged & Major Junc. - 3 Legged	Nos	2
	d) Advance Direction / Destination / Reassurance / Place Identification signs of 1200mm x 1150mm	Major Junctions - 4 - Legged	Nos	2
	e) Route marker signs of rectangular plate of 450mm x 600mm	Major Junctions with SH/NH	Nos	1
B	Cautionary signs			
	a) Cautionary signs of size 600mm	School zone,	Nos	121

S.No	Description	Locations / Usage	Unit	Quantities
	(Triangular)	junctions and Curvatures		
	b) Chevron Boards - Single Chevrons of 500 x 548 (WXH in mm) Sinlge sign post with TWO Chevron Boards	Curvatures	Nos	100
	c) Chevron Boards - Single Chevrons of 500 x 548 (WXH in mm) Sinlge sign post with ONE Chevron Boards	Curvatures	Nos	
C	Mandatory signs, size			
	a) Circular of size 600mm	Speed Restricted Zones & Curvatures	Nos	56
	c) Octagonal of size 750mm	Junctions	Nos	7
D	Object marker (Hazardous)	Bridges & Culverts	Nos	211
E	Convex Mirrors	Hairpin Bends / Blind Curves	Nos	4
F	Road Studs RED -WHITE Bi - directional	Blind Curves, Hairpin Bends & Built-up Locations	Nos	1622
G	Road Studs Yellow Bi - directional	Blind Curves, Hairpin Bends & Built-up Locations	Nos	1622
H	Rumble Strip Markings	Blind curves, Hairpin Bends, School Zone and Junctions	Sq.m	207.90
I	Pedestrian Crossing - Markings	School Zones & Bus stops	Sq.m	176.00
J	Retro refracting tape for Crash Barrier	Along the Crash Barriers	mts	2750
K	AFC sheets for hazards or Fixed Hazards	Along the road side Structures	Mts	200
L	Gantry Boards	At end point of the road	No	1

3.2.2 Site Specific Management Measures

27. As part of the Environmental and Social Impact Assessment, consultations were held along project road at various locations. Based on the outcome of the consultations and site investigations, some location specific management or enhancement measures have been considered for natural water sources and religious shrines/structures (peepal tree with platform) for conservation of natural resources and cultural heritage measures. The list of such locations are given in Table 3-9 and the drawings showing conservation or enhancement measures for these structures/locations are given in the following figures. Adequate cost provisions have been included in ESMP budgetary provisions and included in the Bill No.12 of Bidding Forms.

Table 3-10: Structures considered for Conservation/Renovation and Enhancement Measures

Sl. No.	Chainage	Type of CPR Structure and Conservation/ Renovation & Enhancement Measure considered
1	3+700	Natural Water Source ó Conservation & Enhancement Measure
2	3+999	Religious Shrine ó Renovation

Sl. No.	Chainage	Type of CPR Structure and Conservation/ Renovation & Enhancement Measure considered
3	4+297	Dug well ó Conservation & Enhancement Measure
4	4+515	Primary health Centre ó Provision of Crash Barrier
5	4+773	Private School ó Provision of Noise Barrier* see note below
6	5+321	Religious Shrine/structure (Peepal tree with platform)ó Renovation and Enhancement Measure
7	5+989	Religious Shrine - Relocation & Enhancement Measure
8	8+275	Religious Shrine/structure (Peepal tree with platform)ó Conservation & Enhancement Measure
9	8+280	Natural drinking resourceó Conservation & Enhancement Measure
10	10+416	Natural water resource ó Conservation & Enhancement Measure
11	10+725	Religious Shrine ó Conservation & Enhancement Measure
<p><i>Note- Provision of polycarbonate noise barrier outside the school building has been discussed with the school authority during the Stakeholder consultation as part of ESIA. However, alternative materials or types for noise barrier like use of double-glazed windows for the school building can also be evaluated during the project implementation phase, in consultation with the school authorities, which may require to replace or retrofit all the windows with double glazed shutters.</i></p>		

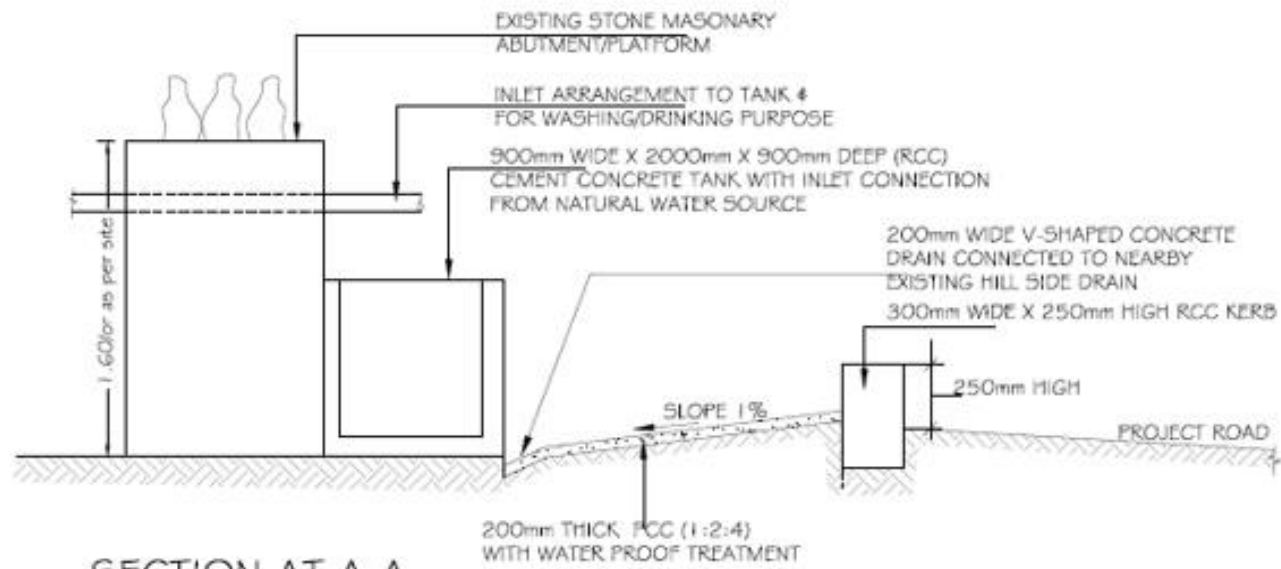

SECTION AT A-A

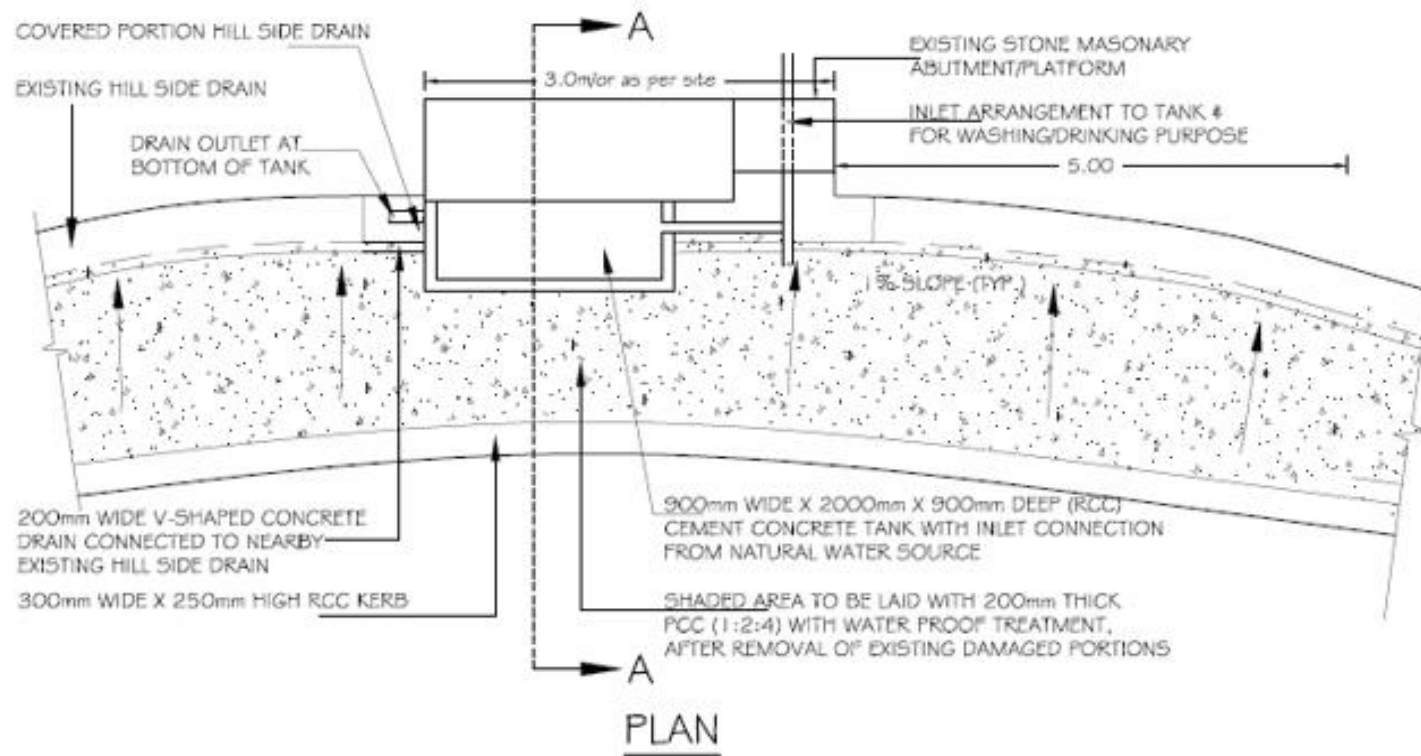

PLAN

RENOVATION OF NATURAL SOURCE AT CH 3+700.

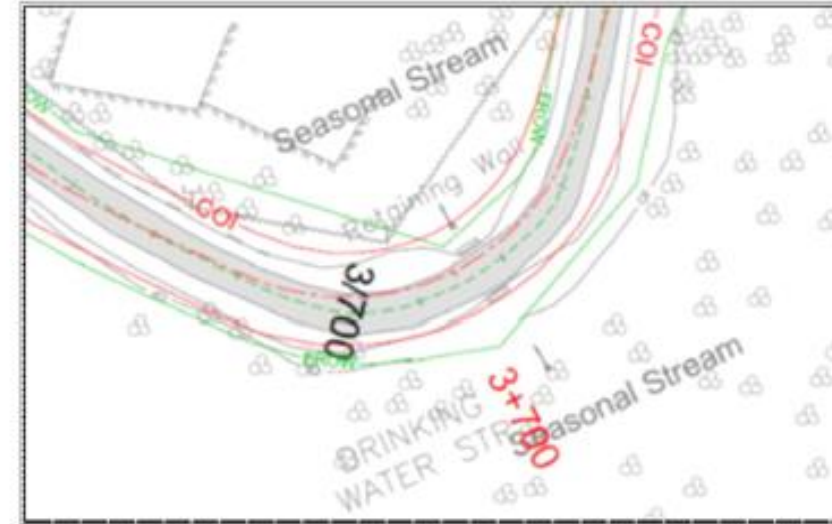

LOCATION PLAN



PRESENT SITE PHOTOGRAPH AT CH 3+700

Items for Renovation of Natural Water Source cum open well at Ch 3+700

1. Carryout minor repairs to the entire masonry of superstructure/masonry block of natural water including filling up cracks and redoing broken edges and sides as required /per site condition and all sides of super structure is finished to slope outwards to avoid stagnation of water around the well
2. Provide 300 mm thick PCC 1:2:4 and a 200 mm deep V shaped drain as per indicated areas in the drawing at water source structure with proper slopes and a RCC kerb along the edge of the road as shown in the drawing to avoid stagnation of water surrounding the water source and spill over of water from source on to the road.
3. Providing cement 12 mm thick plastering in CM 1:4 to all external surfaces of the water source/ well super structure with a neat coat of cement finish
4. Providing two coats of exterior paint/white washing to the entire super structure of source as per site requirements
5. Replace all pipe extensions and plumbing fixtures at water source as well as provide proper inlet connections to all water troughs to facilitate drinking of water by stary animals, grazing cattle as well as for washing of vehicles by road users
6. Removal and/or clearing of unwanted debris/wate material surrounding the water source/ well and disposal of the same at an approved location
7. "3M" make high intensity retro reflective conspicuity tape (2" wide X 1mtr length) shall be pasted along edge of road near structure

Note: All renovation /conservation work shall be carried out in close consultation with local community leaders/regular users of at the water source. All suggestions shall be duly considered with prior approval of Engineer-in-Charge.

Note: Arrangements shown above are for guidance only. Working/GFC drawings are to be prepared by contractor and approved by CSC

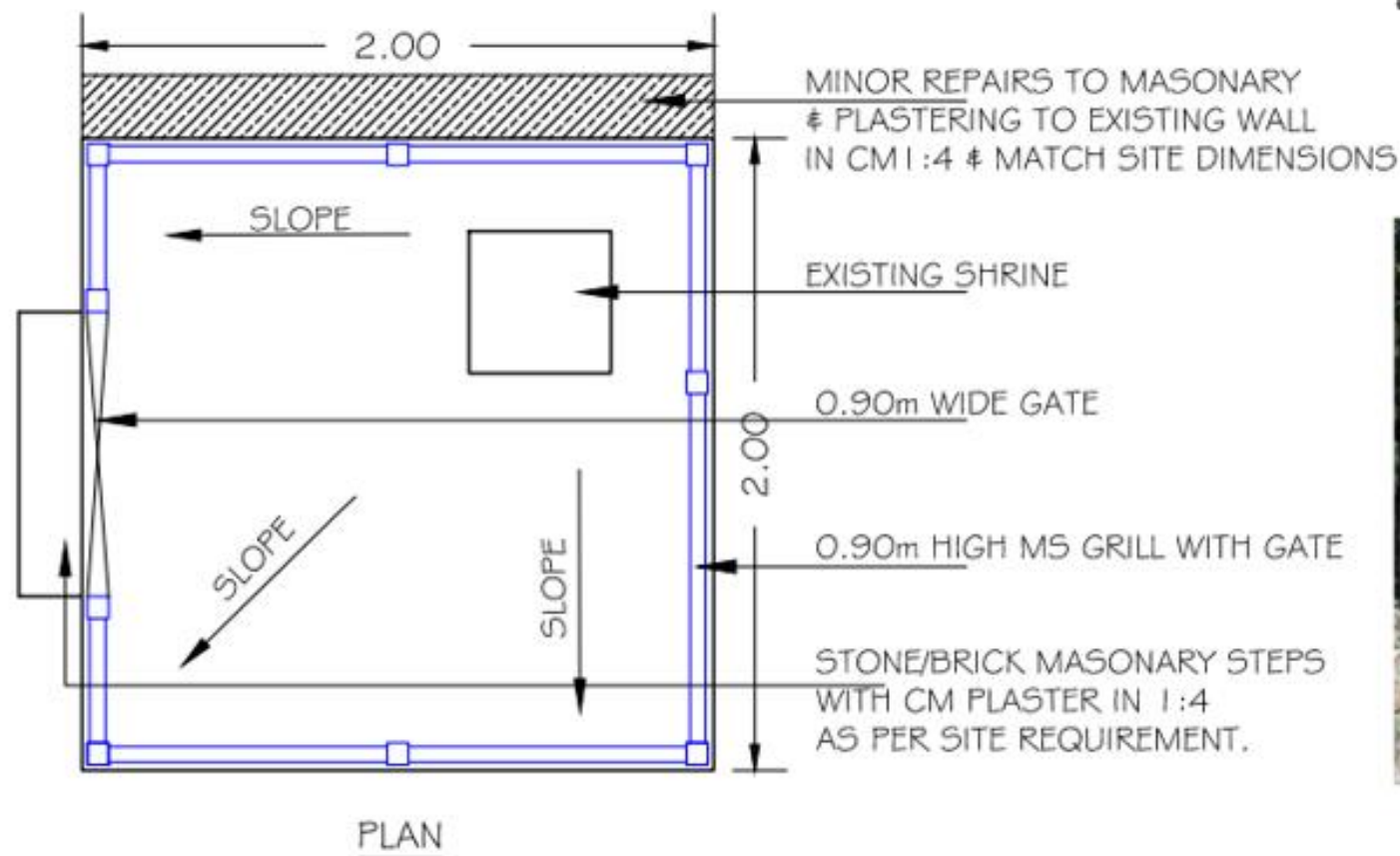
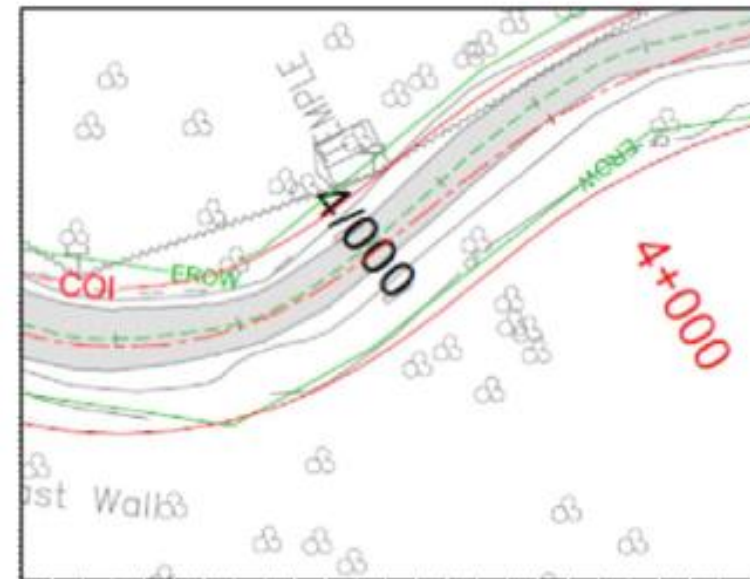
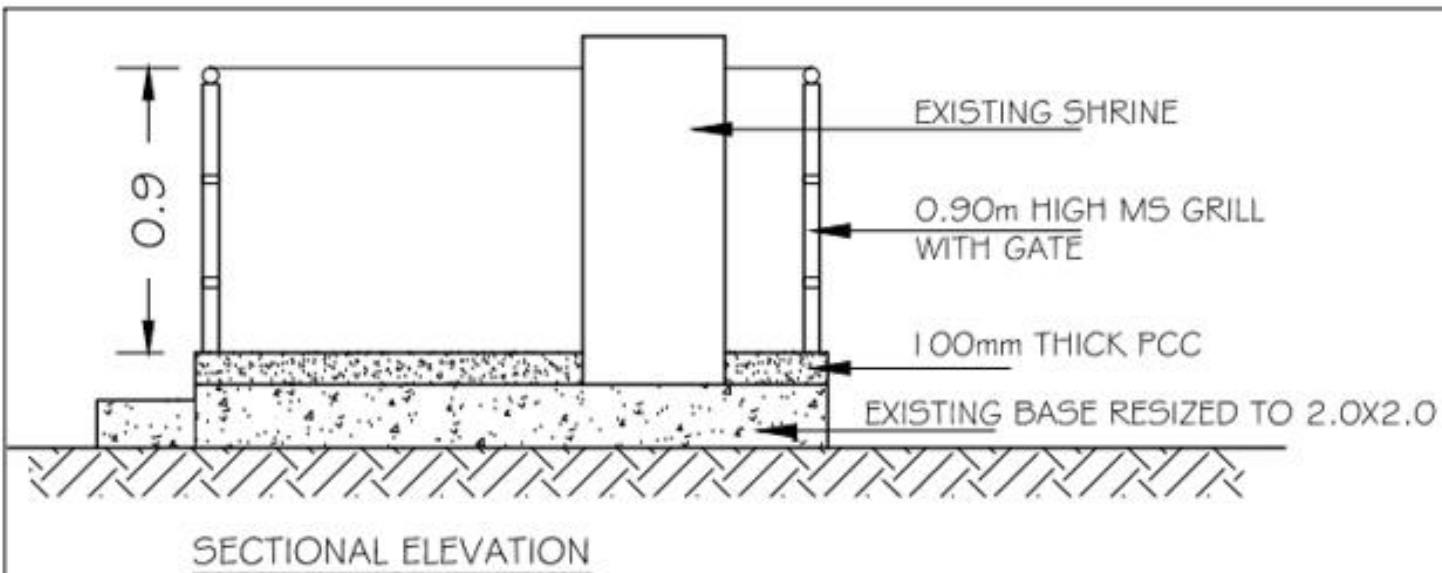

Items for Renovation of Religious Shrine at Ch 3+999

1. Carryout repairs to random rubble masonry wall in CM 1:4 to retain earth at the back side of shrine and plaster the masonry wall in CM 1:4 with 12mm thick. The dimension of structure shall be 2-metre-long, 1.5 metre height and shall vary and match as per site conditions.
2. Resize the existing base of the shrine to 2m X 2m and lay a 100mm thick PCC 1:2:4 bed, sloping outwards as shown in drawings and as per site conditions.
3. Providing and Fixing of MS railing all along the edge of the newly built platform (900 mm height and 8metre long) with a gate for entrance/exit.
4. Provide one or two steps in rubble masonry and plaster the same in CM 1:4 and 12mm thick as per site requirements for easy entry and exit of visitors
5. Provide two coats of exterior paint/white washing to the entire religious shrine as per site conditions/site requirements
6. Removal and/or clearing of unwanted debris/wate material surrounding the shrine and disposal of the same at an approved location
7. "3M" make high intensity retro reflective conspicuity tape (2" wide X 1mtr length) shall be pasted along edge of road near structure

Note: All renovation /conservation work at the religious shrine shall be carried out in close consultation with local community leaders/regular users of shrine. All suggestions shall be duly considered with prior approval of Engineer-in-Charge.

RENOVATION OF RELIGIOUS SHRINE AT CH.3+999.

Note: Arrangements shown above are for guidance only. Working/GFC drawings are to be prepared by contractor and approved by CSC

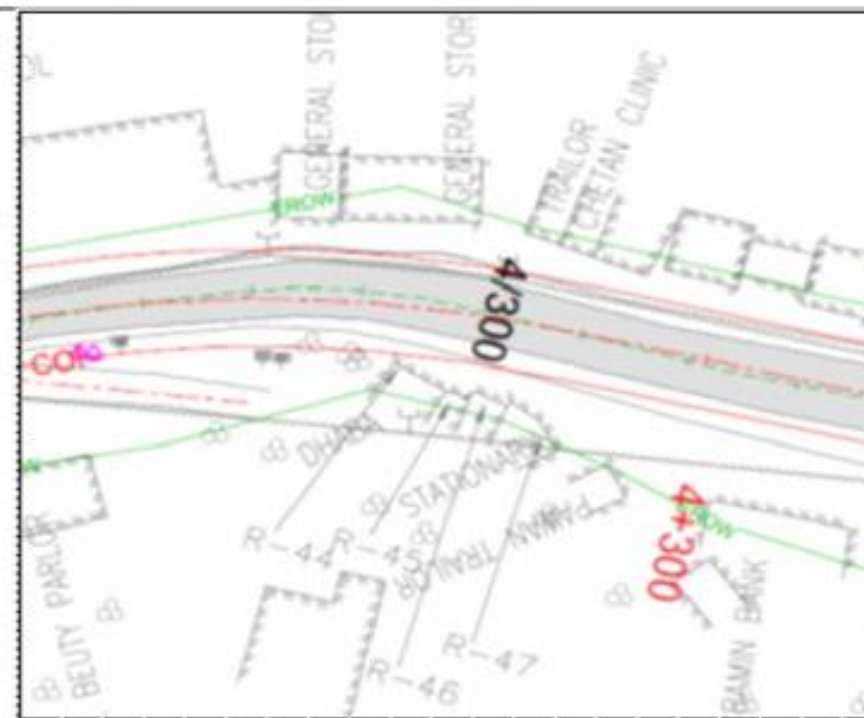
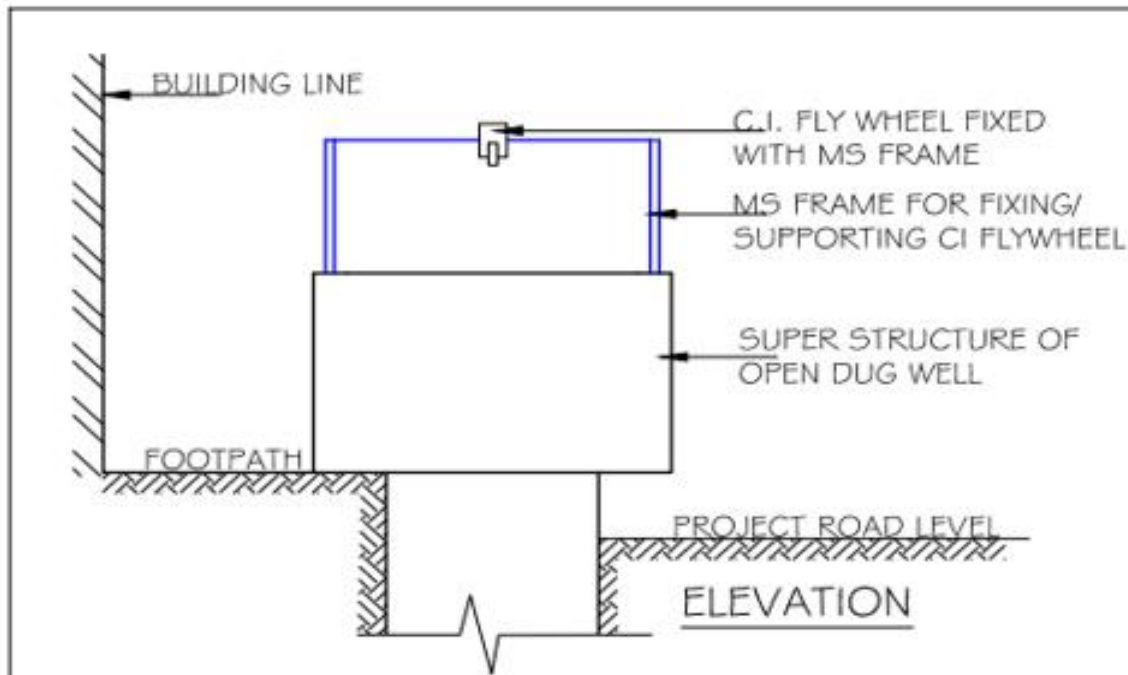

LOCATION PLAN

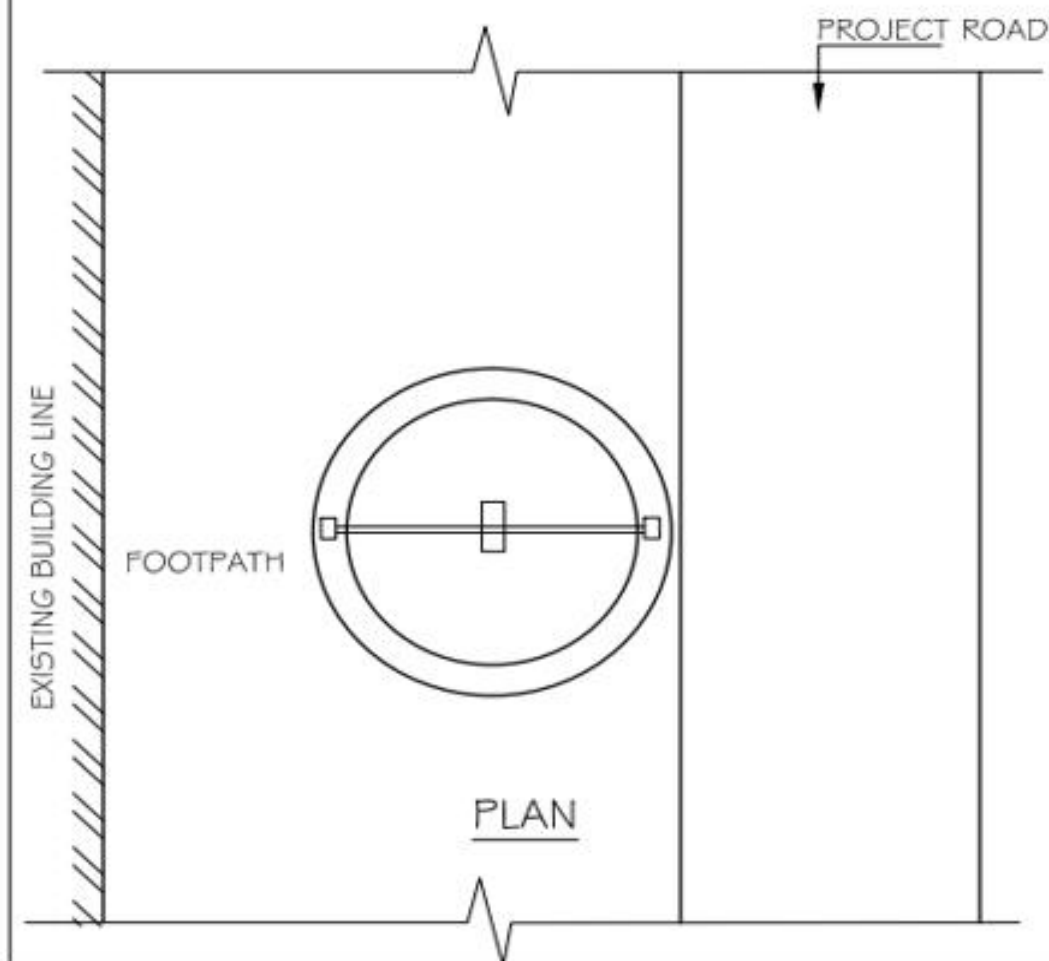

PRESENT SITE PHOTOGRAPH AT CH 4+297

RENOVATION OF OPEN DUG WELL AT CH 4+297.

Items for Renovation of Open Dug Well at Ch 4+297

1. Carryout minor repairs to the entire masonry of superstructure of open well including filling up cracks and redoing broken edges and sides as required /per site condition and all sides of well super structure is finished to slope outwards to avoid stagnation of water around the well
2. Providing and Fixing of M. S. Frame with required sizes and thickness on the parapet wall of the dug well super structure to support C.I. Fly wheel and facilitate drawing of water as shown in drawing /as per site requirements
3. Provide appropriate drainage around the well and connect it to the nearby roadside drain to avoid stagnation of water spills surrounding the well
4. Providing cement 12 mm thick plastering in CM 1:4 to all external surfaces of the dug well super structure with a neat coat of cement finish
5. Providing two coats of exterior paint/white washing to the entire super structure of dug well including anti corrosive painting to M S frame supporting the fly wheel as per site requirements
6. Removal and/or clearing of unwanted debris/wate material surrounding the dug well and disposal of the same at an approved location
7. "3M" make high intensity retro reflective conspicuity tape (2" wide X 1mtr length) shall be pasted along edge of road near structure

Note: All renovation /conservation work shall be carried out in close consultation with local community leaders/regular users of at the open dug well. All suggestions shall be duly considered with prior approval of Engineer-in-Charge.

Note: Arrangements shown above are for guidance only. Working/GFC drawings are to be prepared by contractor and approved by CSC

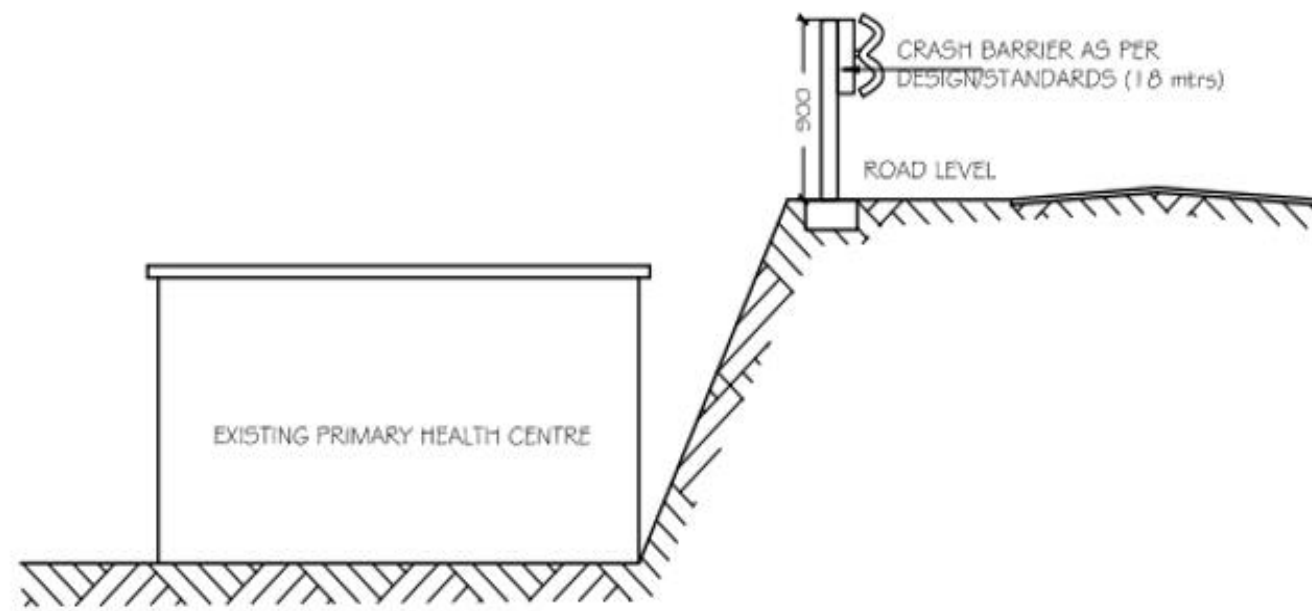

SECTION AT A-A

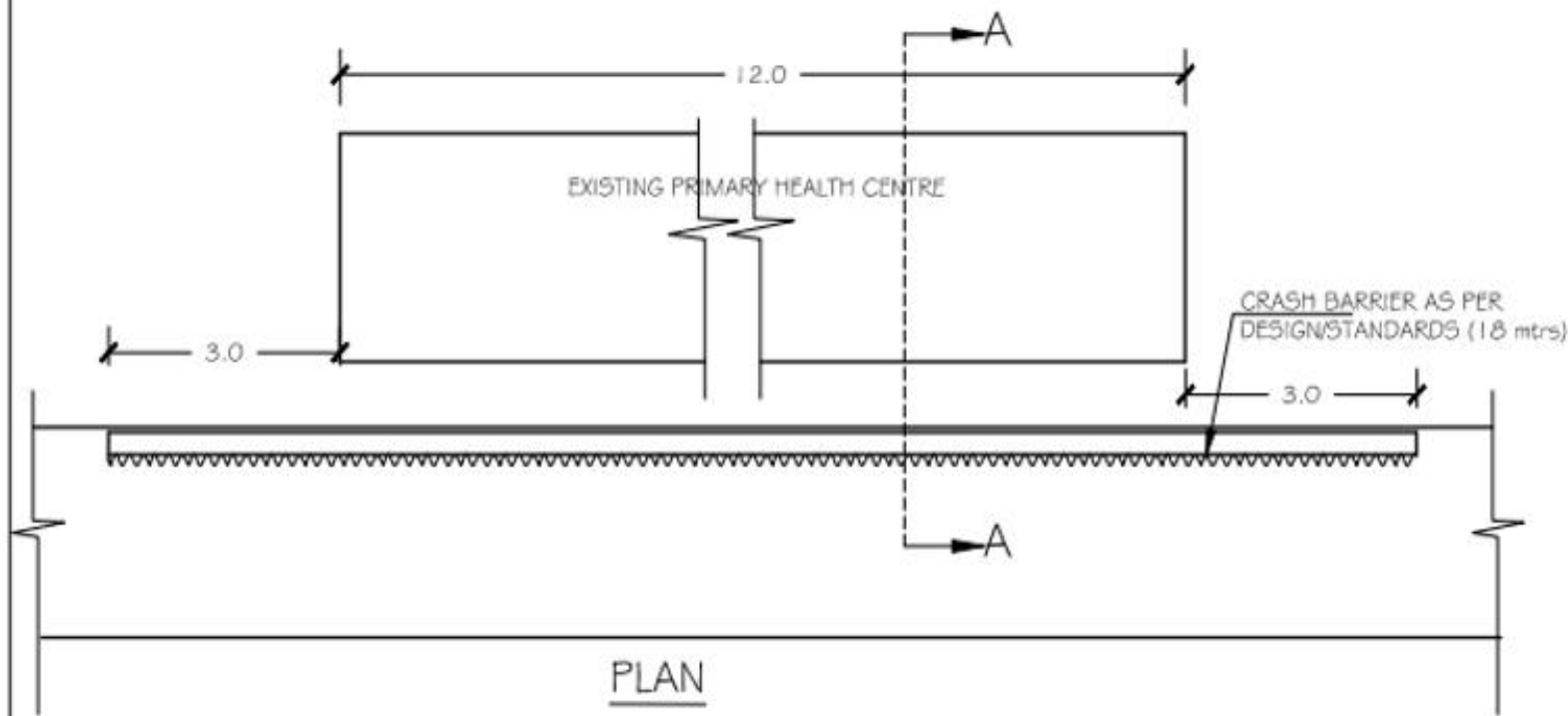

PLAN

PROVISION OF CRASH BARRIER AT CH.4+515.

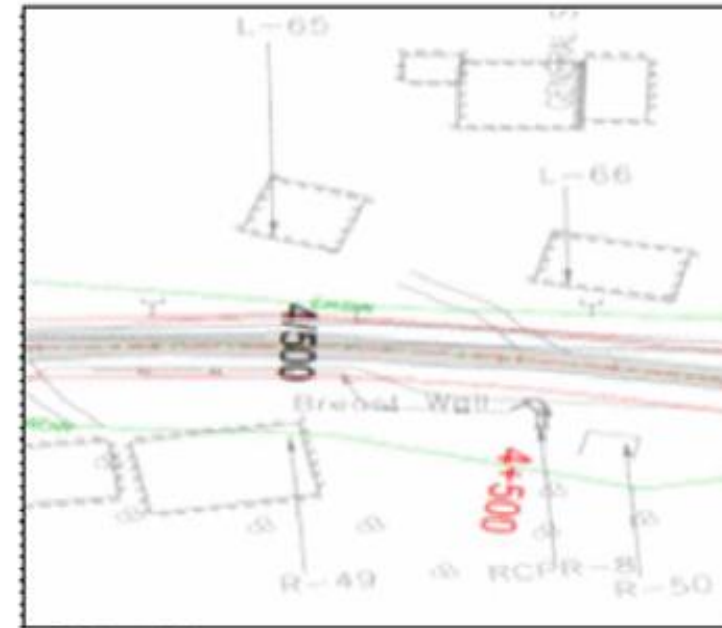

LOCATION PLAN



PRESENT SITE PHOTOGRAPH AT CH 4+515

Items for Safety Enhancement of Sensitive Receptor (primary health centre) at Ch 4+515

1. Provide crash barrier for the entire length of the sensitive receptor with atleast 3m additional length on both side of the sensitive receptor
2. The crash barrier shall be as per standard specifications
3. Removal and/or clearing of unwanted debris/wate material along the road side and back side of the sensitive receptor and disposal of the same at an approved location
7. "3M" make high intensity retro reflective conspicuity tape (2" wide X 1mtr length) shall be pasted along edge of road near structure

Note: The primary health centre shall be consulted during the installation of crash barrier and suggestions received from health centre shall be duly considered with prior approval of Engineer-in-Charge.

Note: Arrangements shown above are for guidance only. Working/GFC drawings are to be prepared by contractor and approved by CSC

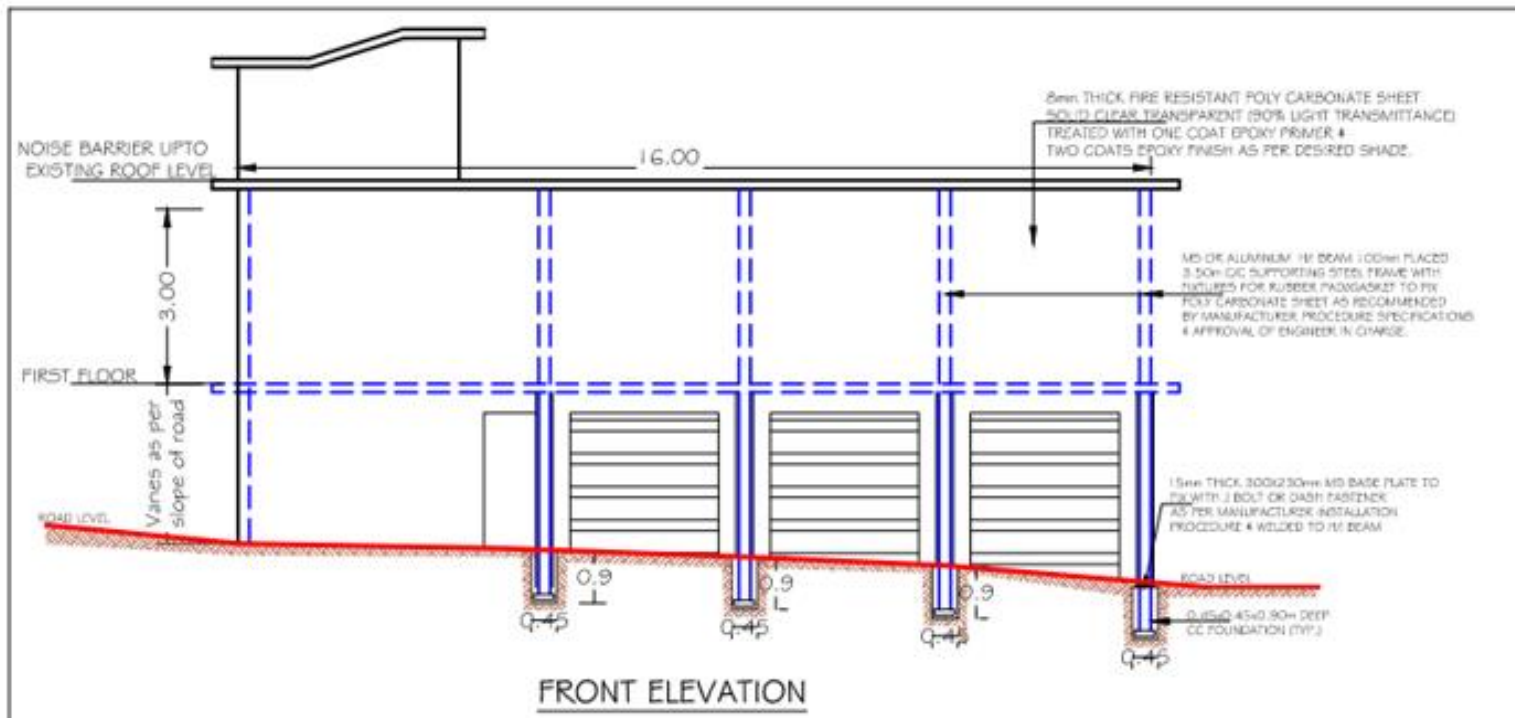

FRONT ELEVATION

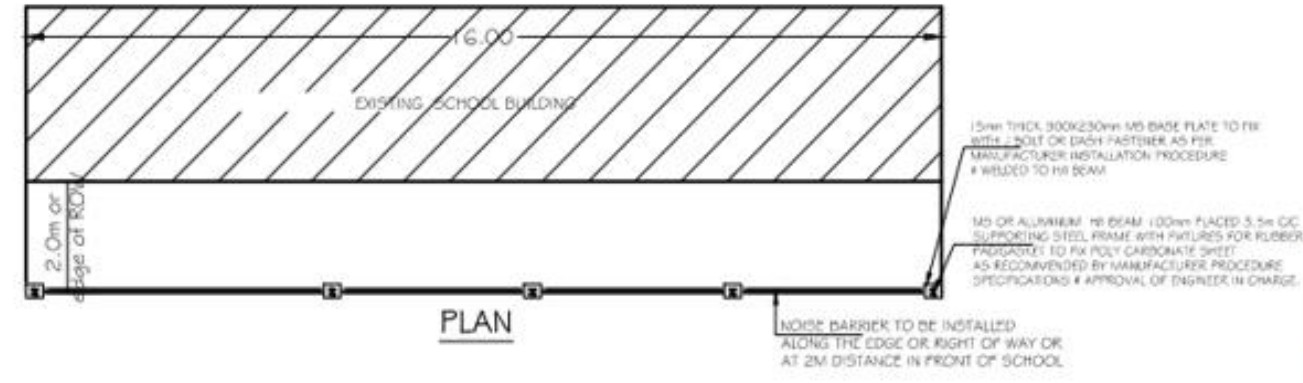

PLAN

- NOTES :-
- i) Noise barrier to be installed along the edge or Right of way or at 2m distance in front of school.
 - ii) All dimensions shown are to be verified at site.
 - iii) Noise barrier design and general arrangement to be confirmed with school authorities.
 - iv) All dimensions are in metres unless otherwise specified.

NOISE BARRIER AT CH.4+773 (SARASWATI VIDYA MANDIR MIDDLE SCHOOL TALYAHAR)



LOCATION PLAN



PRESENT SITE PHOTOGRAPH AT CH.4+773

Items for Noise Barrier for Sensitive Receptor at Ch 4+773 (Saraswathi Vidya Mandir Middle School)

1. Initiate consultation with the school authorities about the noise barrier design, general arrangement and installation requirements and benefits of reduction in ambient noise levels for the school due to installation of noise barrier.
2. Consultation during ESIA with School authorities had broadly indicated no objection to installation of noise barrier in front of school, if it does not obstruct the light and at no cost to school.
3. Plan and schedule the installation of noise barrier during school holidays and/or weekends to avoid disruption to school activities and ensure utmost safety to school children. Examination days shall be strictly avoided for any construction activity near school premises.
4. Plan and complete the installation of noise barrier in ONE-GO and in limited time frame. Installation of Noise barriers in multiple schedules shall be avoided to the extent possible.
5. Ensure the entire installation of noise barrier at school premises by the supplier/fabricator is well supervised and all required safety measures for school children and public and road users including plying traffic during installation.
6. Ensure the noise barrier is adequately designed, fabricated and installed to withstand the known maximum wind speed known for the region and as per relevant as per standards.
7. Removal and/or clearing of unwanted debris/water material in the premises and/or on road during installation of noise barrier and disposal of the same at an approved location.
8. Installation of the noise barrier shall preferably completed prior to commencement of construction related to the road widening works.
7. "3M" make high intensity retro reflective conspicuity tape (2" wide X 1mtr length) shall be pasted along edge of road near structure.

Note: Any suggestions by the school authorities on the noise barrier design, fabrication, installation, safety aspects and aesthetics shall be duly considered with prior approval of Engineer in Charge

Note: Arrangements shown above are for guidance only. Working/GFC drawings are to be prepared by contractor and approved by CSC

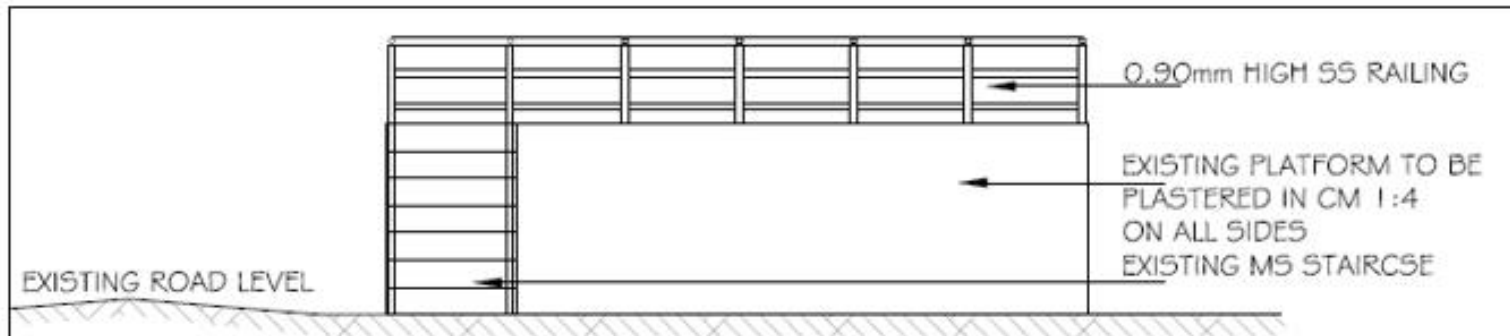

ELEVATION

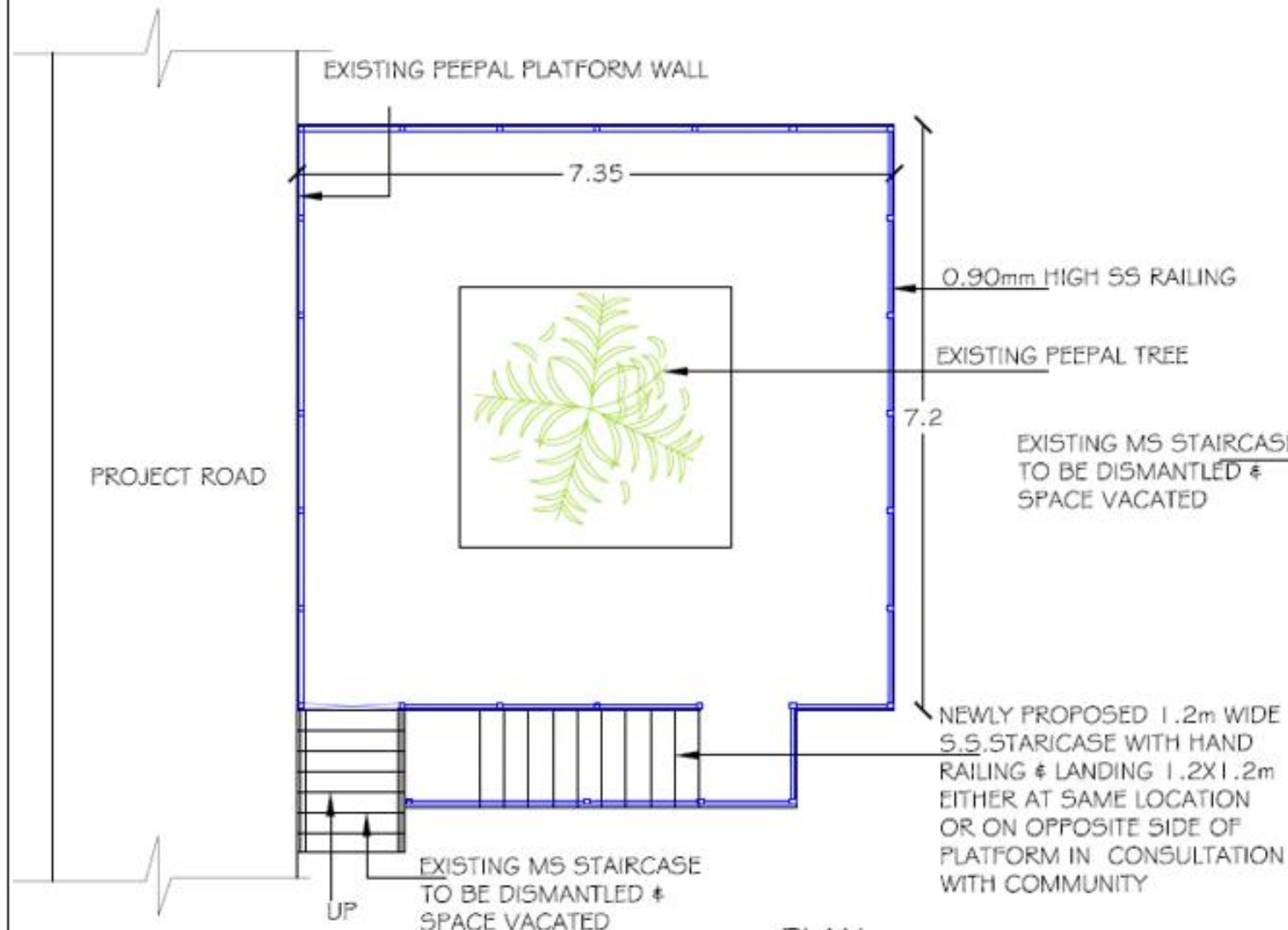

PLAN

RENOVATION OF RELIGIOUS SHRINE AT CH 5+32 I



LOCATION PLAN



PRESENT SITE PHOTOGRAPH AT CH 5+32 I

Items for Renovation of Religious Shrine at Ch 5+321

1. Carryout repairs to peepal tree platform wall in CM 1:4 and plaster the masonry wall in CM 1:4 with 12mm thick. The dimension of structure shall be 7.2 X 7.35 with 2 metre high as per site and indicated in the drawing
2. Providing and Fixing of MS railing 900 mm high SS railing all along the edge of platform with a gate for entrance/exit.
3. Provide hand railing to already existing MS steps for climbing on to platform as per site requirements for safety, easy entry and exit of visitors
4. Provide two coats of exterior paint/white washing to the entire religious shrine as per site conditions/site requirements
5. Removal and/or clearing of unwanted debris/waste material surrounding the shrine and disposal of the same at an approved location
7. "3M" make high intensity retro reflective conspicuity tape (2" wide X 1mtr length) shall be pasted along edge of road near structure

Note: All renovation /conservation work at the religious shrine shall be carried out in close consultation with local community leaders/regular users of shrine. All suggestions shall be duly considered with prior approval of Engineer-in-Charge.

Note: Arrangements shown above are for guidance only. Working/GFC drawings are to be prepared by contractor and approved by CSC

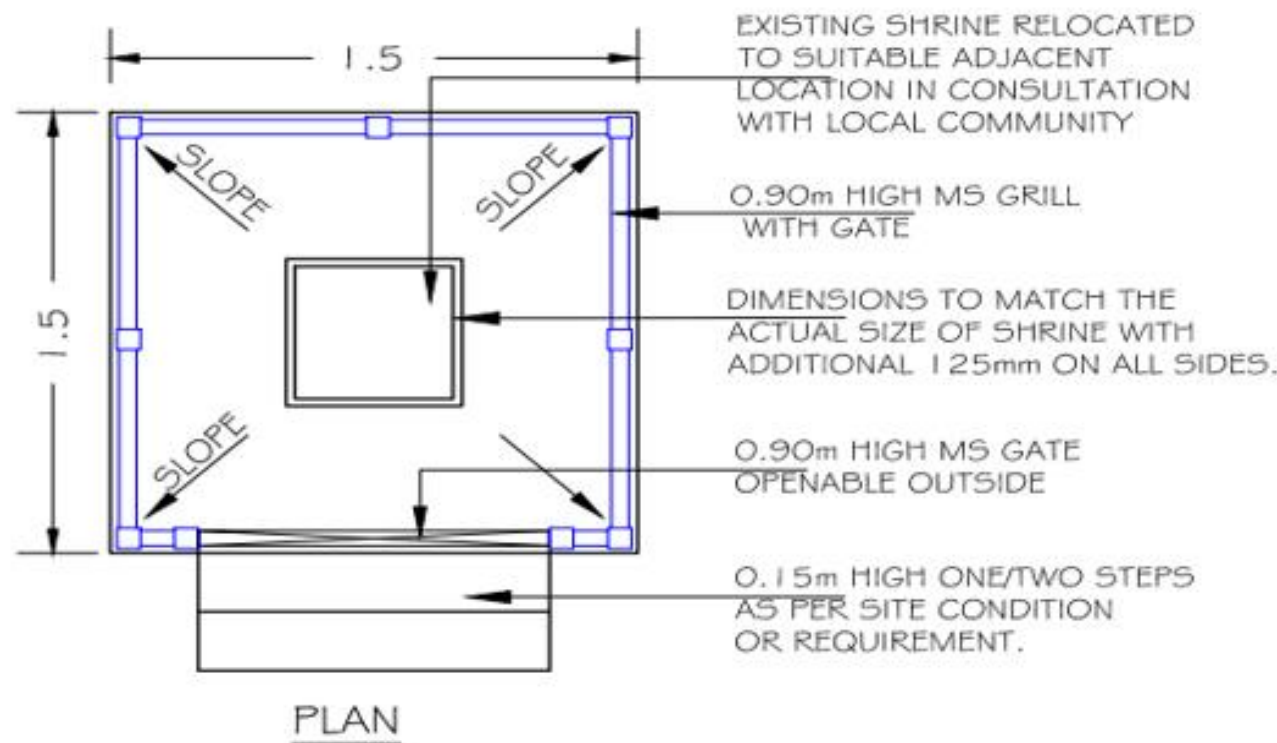
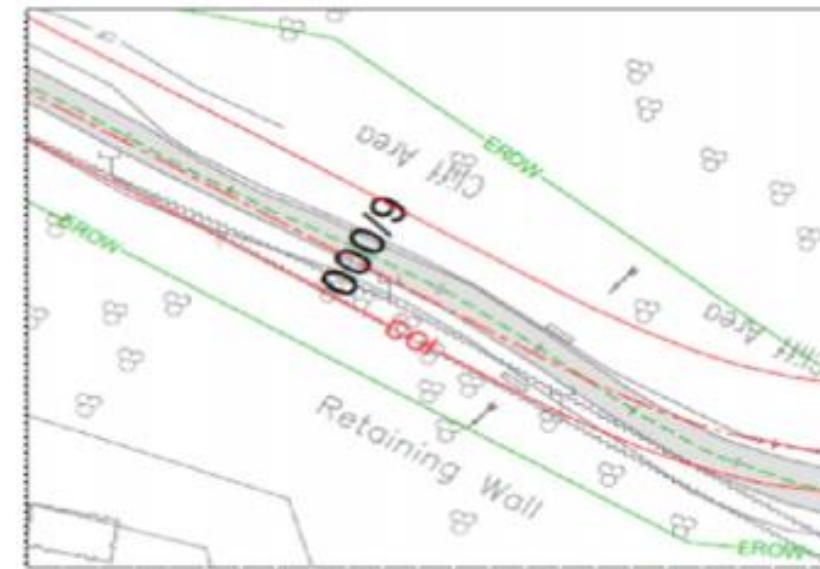
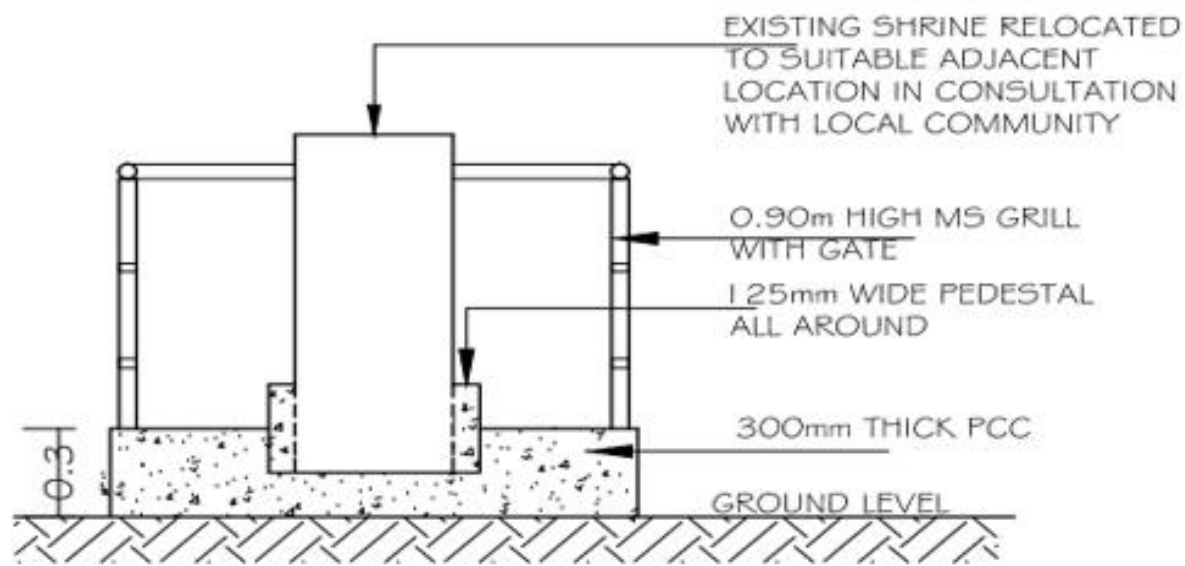

Items for Relocation of Religious Shrine at Ch 5+989

1. Identify a suitable location, within the proximity of existing location of the shrine but beyond the construction disturbance zone, in consultation with the local community leaders and or regular visitors to shrine
2. Clear and prepare the identified site for construction of platform as shown in the drawings/as per site requirements
3. All construction work for relocation of shrine shall be undertaken as shown in drawing /site construction and as agreed upon with the local community leaders and or regular visitors to shrine
4. All relocation work shall be completed prior to commencement of construction works related to road widening
5. Ensure utmost care and the shrine is handled diligently and carefully, while shifting from its existing location to the new location, in cooperation and/or consultation with local community leaders and or regular visitors to shrine
6. All works related to relocation of the religious shrine shall be essentially completed prior to commencement of construction related to the road widening works
7. Once the relocation is completed and all civil works are completed as shown in drawings/site requirements, facilitate a pooja ceremony to the satisfaction of local community/ regular visitors prior to handing over of the shrine
7. "3M" make high intensity retro reflective conspicuity tape (2" wide X 1mtr length) shall be pasted along edge of road near structure

Note: All relocation work including the civil works shall be carried out in close consultation with local community leaders/regular users of shrine. All suggestions shall be duly considered with prior approval of Engineer-in-Charge.

RELOCATION & RENOVATION OF RELIGIOUS SHRINE AT CH.5+989.

Note: Arrangements shown above are for guidance only. Working/GfC drawings are to be prepared by contractor and approved by CSC



STEP TO BE SHIFTED FROM EXISTING POSITION TOWARDS LEFT HAND SIDE OR AS PER SITE CONDITION WITH SAME MARBLE FINISH



LOCATION PLAN



PRESENT SITE PHOTOGRAPH AT CH 8+275

SHIFTING OF STEP AT PEPPAL PLATFORM AT CH 8+275.

Items for Relocation of climbing Steps of Religious Shrine at Ch 8+275

1. Clear and prepare the identified side of the platform for shifting/relocating the climbing steps to the platform as shown in the drawings/as per site requirements
2. All construction work for relocation of climbing steps to the shrine shall be undertaken as shown in drawing /site construction and as agreed upon with the local community leaders and or regular visitors to shrine
3. All relocation work shall be completed prior to commencement of construction works related to road widening and same type of finish shall be achieved to the extent possible.
4. Ensure utmost care and the shrine is handled diligently and carefully, while shifting from its existing location to the new location, in cooperation and/or consultation with local community leaders and or regular visitors to shrine
5. All works related to relocation of steps of the religious shrine shall be essentially completed prior to commencement of construction related to the road widening works
6. Once the relocation is completed and all civil works are completed as shown in drawings/site requirements, facilitate a pooja ceremony to the satisfaction of local community/regular visitors prior to handing over of the shrine
7. "3M" make high intensity retro reflective conspicuity tape (2" wide X 1mtr length) shall be pasted along edge of road near structure

Note: All relocation work including the civil works shall be carried out in close consultation with local community leaders/regular users of shrine. All suggestions shall be duly considered with prior approval of Engineer-in-Charge.

Note: Arrangements shown above are for guidance only. Working/GfC drawings are to be prepared by contractor and approved by CSC

Items for Renovation of Natural Water Source cum open well at Ch 8+280

1. Carryout minor repairs to the entire masonry of superstructure of natural water source cum open well including filling up cracks and redoing broken edges and sides as required /per site condition and all sides of well super structure is finished to slope outwards to avoid stagnation of water around the well
2. Construct a 300 mm wide parapet wall with 900 mm height around the natural water source/well as well as 900 mm wide PCC platform all sides of the water source/well to facilitate water drawing by women and local people
3. Remove the existing RCC roof and increase the height of the superstructure to 3 metre and make it suitable for installation of a truss roof to support transparent poly carbonate sheets for at least 90% light transmittance as shown in the drawing /as per site requirements
4. Providing and Fixing of M. S. Frame with required sizes and thickness on the parapet wall of the water structure/well super structure to support C.I. Fly wheel and facilitate drawing of water as shown in drawing /as per site requirements
5. Provide appropriate drainage around the well and connect it to the nearby roadside drain to avoid stagnation of water surrounding the water source/well
6. Providing cement 12 mm thick plastering in CM 1:4 to all external surfaces of the water source/ well super structure with a neat coat of cement finish
7. Providing two coats of exterior paint/white washing to the entire super structure of dug well including anti corrosive painting to M S frame supporting the fly wheel as per site requirements
8. Removal and/or clearing of unwanted debris/water material surrounding the water source/ well and disposal of the same at an approved location
9. "3M" make high intensity retro reflective conspicuity tape (2" wide X 1mtr length) shall be pasted along edge of road near structure

Note: All renovation /conservation work shall be carried out in close consultation with local community leaders/regular users of at the water source/ open well. All suggestions shall be duly considered with prior approval of Engineer-in-Charge.

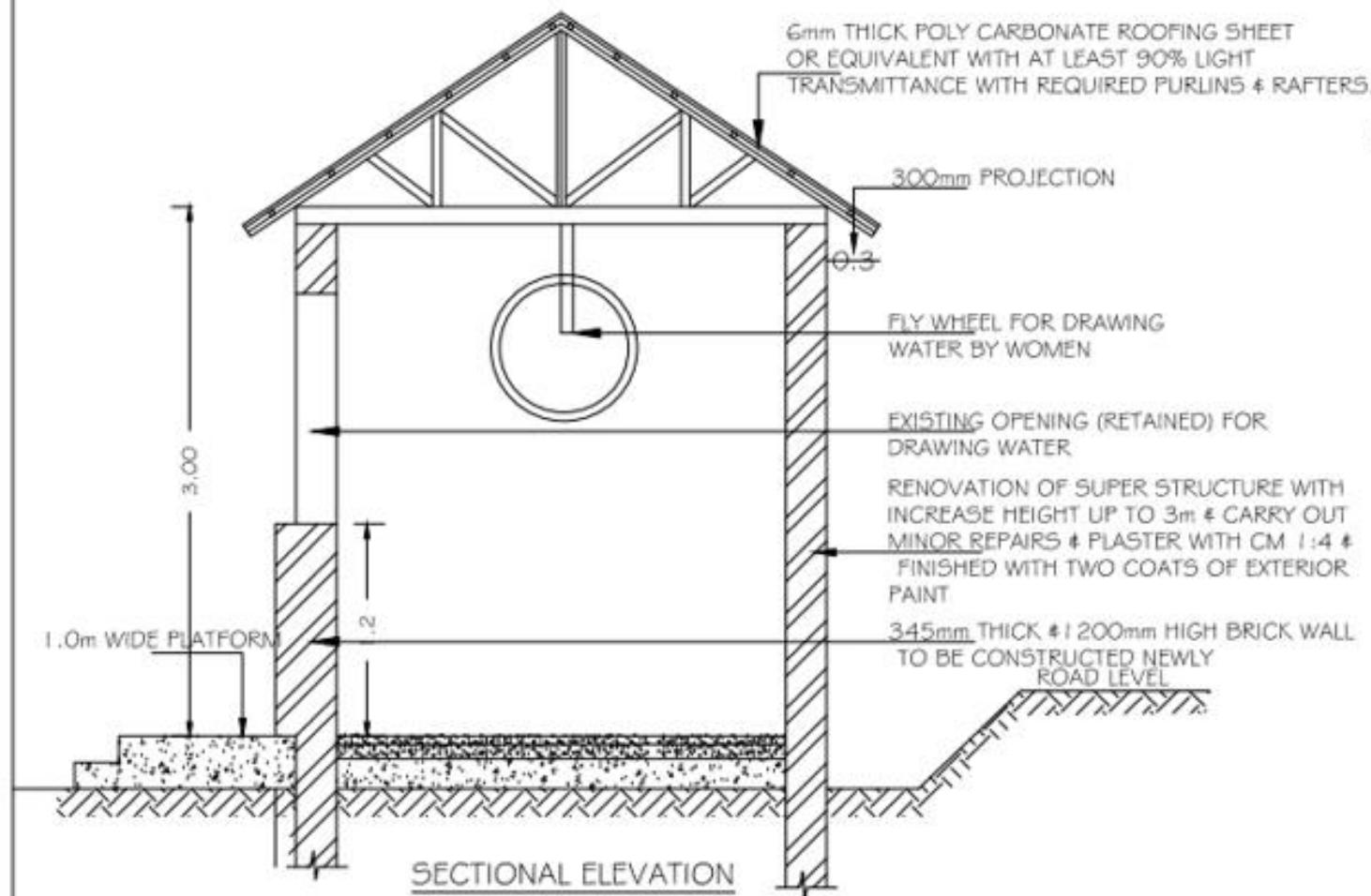
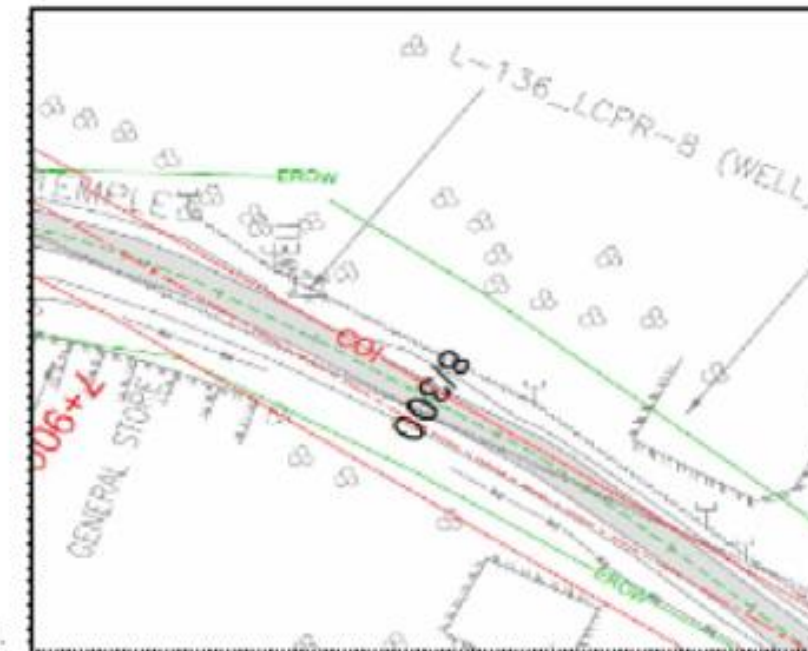
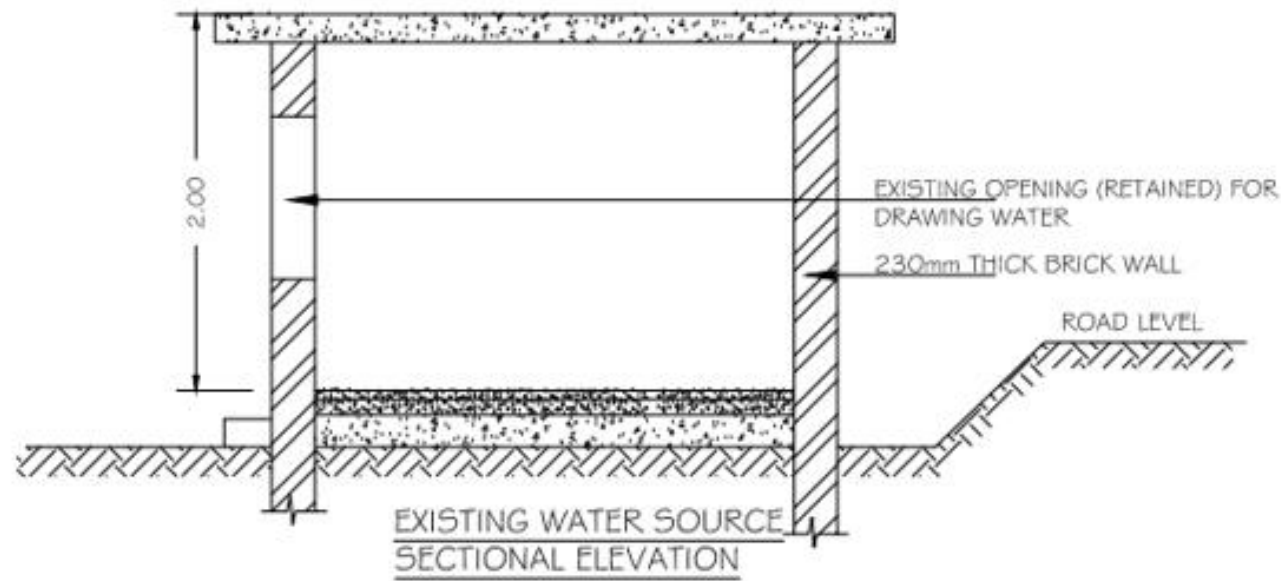

LOCATION PLAN



RENOVATION OF NATURAL SOURCE AT CH 8+280.

Note: Arrangements shown above are for guidance only. Working/GFC drawings are to be prepared by contractor and approved by CSC



PRESENT SITE PHOTOGRAPH
AT CH 10+416

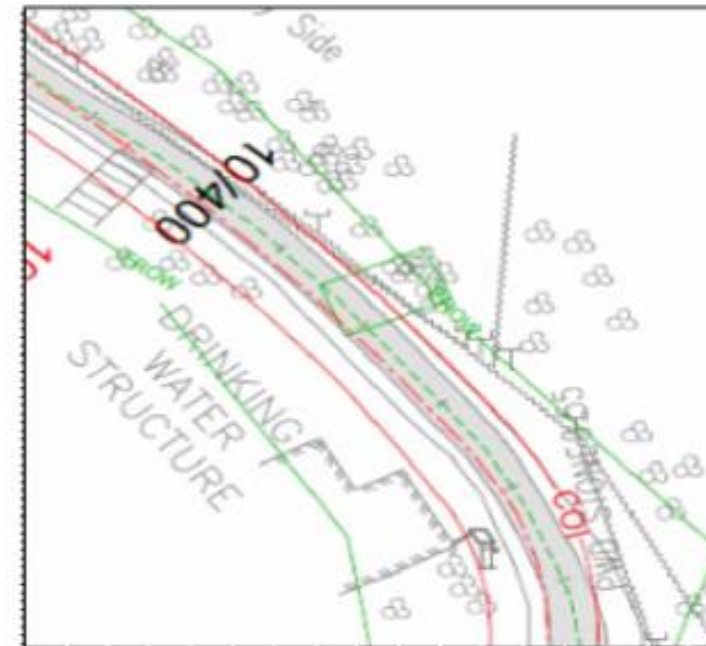

LOCATION PLAN



MINOR REPAIR TO ROOF
(BOTH INSIDE & OUTSIDE) WITH
12mm THICK PLASTER IN CM 1 :4

MINOR REPAIR TO SUPER STRUCTURE
(BOTH INSIDE & OUTSIDE) WITH 12mm
THICK PLASTER IN CM 1 :4

RECONSTRUCTION OF STEPS IN
RANDOM RUBBLE MASONRY IN CM 1 :4

RENOVATION OF NATURAL WATER SOURCE AT CH 10+416.

Items for Renovation of Natural Water Source at Ch 10+416

1. Install a new pre-cast RCC tank of 2000 litres capacity or rectangular shaped poly-propylene (pre-fabricated) tank in a suitable location in close proximity to natural water source, on a firm and 100 mm thick level bed of PCC.
2. Connect the newly placed tank with required pipe connections and plumbing fixtures to the natural water source
3. Place a pre-cast concrete trough 1.5 m long, 0.45 m wide and 0.45 m deep to facilitate drinking of water by stary animals and grazing cattle and connect it to pre-cast water storage tank as shown in drawing /as per site requirements
4. Level the area and provide 150 mm thick PCC in and around the natural water source, storage tank and trough, and PCC finished with sloping outwards to drain the water and no water stagnate as required /per site condition
5. Providing two coats of exterior paint/white washing to the entire water body structure as per site conditions/site requirements
6. Dismantle existing pre-cast tank and remove and/or clearing of unwanted debris/wate material surrounding the water source and disposal of the same at an approved location
7. "3M" make high intensity retro reflective conspicuity tape (2" wide X 1mtr length) shall be pasted along edge of road near structure

Note: All renovation /conservation work at the natural water source shall be carried out in close consultation with local community leaders/regular users of water source. All suggestions shall be duly considered with prior approval of Engineer-in-Charge.

Note: Arrangements shown above are for guidance only. Working/GFC drawings are to be prepared by contractor and approved by CSC

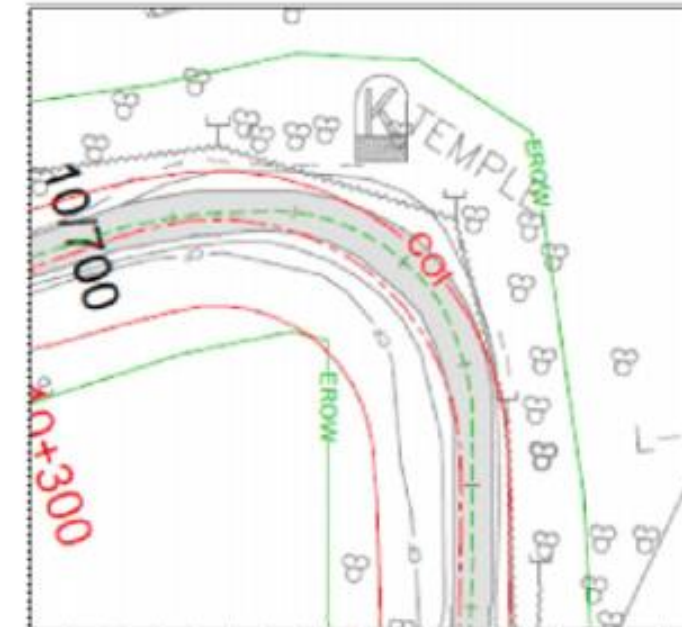
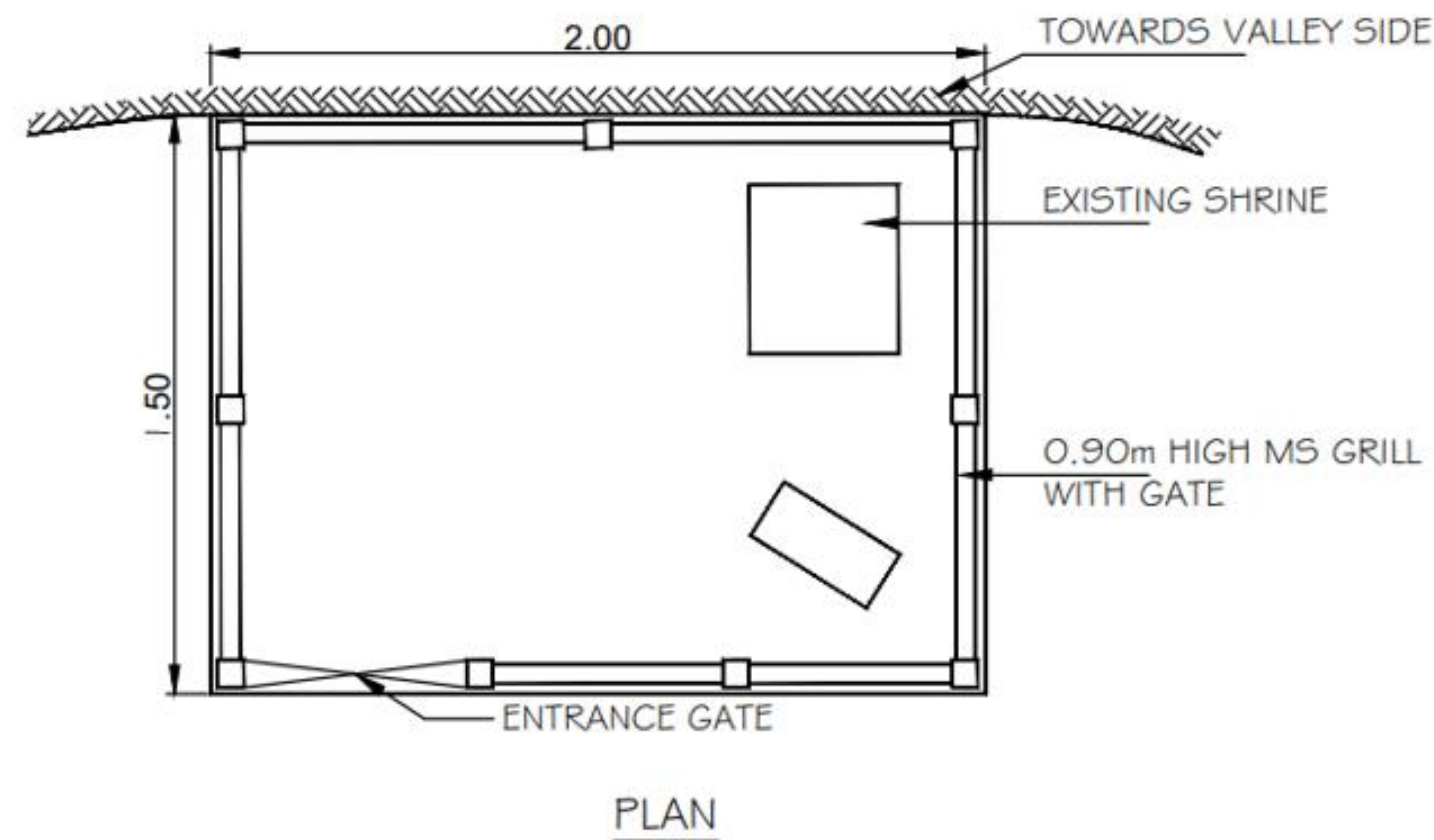
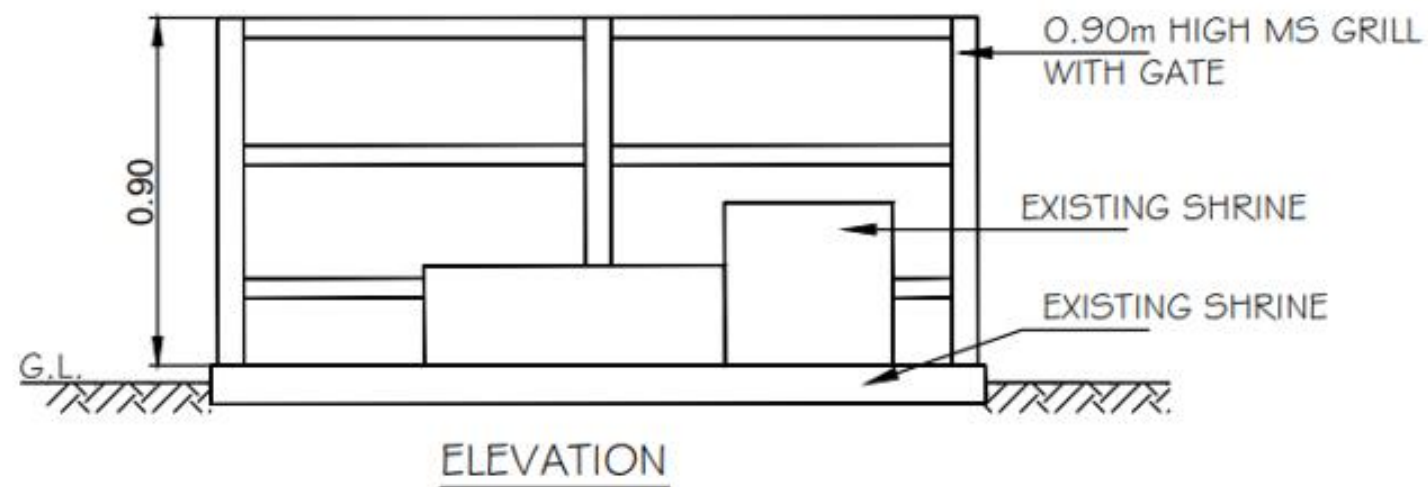

Items for Enhancement of Religious Shrine at Ch 10+725

1. Resize the existing platform as shown in the drawings
2. Carryout repairs to masonry wall in CM 1:4 at the back of shrine to retain earth and plaster the masonry wall in CM 1:4 with 12mm thick. The dimension of structure shall vary and match as per site conditions.
3. Provide and fix a MS grill 900 mm height all-round the shrine with an entrance gate
4. Providing two coats of exterior paint/white washing to the entire religious as per site conditions/site requirements
5. Removal and/or clearing of unwanted debris/wate material along the roadside and back side of the sensitive receptor and disposal of the same at an approved location
7. "3M" make high intensity retro reflective conspicuity tape (2" wide X 1mtr length) shall be pasted along edge of road near structure

Note: All resizing and renovation /conservation work at the religious shrine shall be carried out in close consultation with local community leaders/regular users of shrine. All suggestions shall be duly considered with prior approval of Engineer-in-Charge.

RENOVATION OF RELIGIOUS SHRINE AT CH 10+725

Note: Arrangements shown above are for guidance only. Working/GFC drawings are to be prepared by contractor and approved by CSC

4. ENVIRONMENT AND SOCIAL MANAGEMENT PLAN

28. The environment and social impact mitigation and management measures during pre-construction, construction & operation phases of the project road are described in this section and summarized in **Table 4-1**.

4.1 Pre-Construction Stage Activities by CSC

29. Prior to the Contractor's mobilization, the Construction Supervision Consultant (CSC) will be responsible to ensure that encumbrance free road stretches are readied/prepared for handing over to contractor.

30. The pre-construction stage activities by CSC shall comprise but not limited to the following

- Obtaining permissions for felling of 360 trees from the Department of Forests, GoHP which are within right of way and essentially to be cleared for road widening and ensuring timely felling of trees through the Forest Department, including removal of all stubs and clearance of site;
- Ensuring all utility utilities, which are within Right of way like water supply pipelines, electric poles, transformers, telephone poles etc. in accordance with encumbrance removal plan and close coordination with respective line departments;
- Co-ordination with HPRIDCL appointed NGO for implementation of RAP for the project corridors and ensure all encroachments within right of way by non-titleholders/ encroachers are removed, after disbursement of compensation, duly in accordance with RPF/RAP under HPSRTP. No encroachments shall be removed, prior to disbursement of entitlements and in case of any grievances, same shall be redressed, prior to removal of encroachment
- Ensure all grievances of PAHs are received and are resolved in accordance with established GRM
- Prioritize the stretches for handing over to the contractor for commencement of construction

Pre-Construction Activities by Contractor

31. The pre-construction stage activities of contractor involve;

- Procurement and mobilization of construction equipment / machinery such as crushers, hot mix plants, batching plants and other construction equipment and machinery
- Identification and selection of material sources (quarry and borrow material, water, sand etc.) and debris disposal locations
- Planning traffic diversions and detours, including arrangements for establishing campsites, workforce camps, material stack yards, crusher units, batch mix plants for WMM and concrete, hot mix plants, rented accommodation for supervisory staff. This activity includes identification of suitable lands, wherever required and obtaining requisite permissions or closing lease agreements
- Applying and obtaining of requisite permits/ licenses/ clearances like CTE, CTO, permissions for construction water sourcing, labour permission and similar other regulatory compliance requirements.
- Preparation of C-ESMP which include, OHS plan, Water and Waste Management Plan, Influx management Plan, Worker's camp management plan, CHS Plan, Transport (or road safety) management Plan, Quarry/borrow area management plan, establishment of GRM for labour and Site restoration Plan among others in accordance with the GoI and/or IFC /WB/EBRD

workers Accommodation guidelines. All such plans prepared by contractor will be reviewed and approved by the CSC, prior to commencement of construction works.

4.2 Construction Stage Activities by the Contractor

32. The environmental impact mitigation and management measures anticipated during different stages of project road construction as here under.

- General measures, which are akin to Good International Industry Practice (GIIPs), considered incidental to works and deemed to be included in the quoted bid price by the contractor.
- Project road specific mitigation measures and/or environmental enhancement measures considered as additional requirements that are to be implemented by the contractor against budget provision/ quoted bid price by the contractor.

33. The general measures (GIIPs) which are incidental to works as well as project road specific mitigation measures are described in **Tables 4-1** as ESMP. These will be integrated in the contract/bidding documents as mandatory contractual obligations of contractor. Thus, the contractor is expected to be fully conversant with the ESMP requirements of project road construction of road and accordingly make requisite cost provisions for implementing the SEMP at the bidding stage itself.

34. The construction stage activities require careful management to avoid environmental impacts. The activities that trigger the need for environmental management measures include a) Implementation of site-specific mitigation/management measures b) Monitoring the environmental quality parameters along project road operational sites and other sites like material stack yard, camp site offices, workforce camps, hot mix plants, crusher sites, batch mix plants. Environmental monitoring parameters may include air, noise, water and soil.

35. In addition, social issues which needs to be handled during construction phase include:

- Loss of land due to land-slides resulting from hill cutting activities
- Vibrations and cracks in structures or damage in buildings (of all types) adjacent to RoW due to construction works e.g., hill cutting activities within RoW
- Drying up of seasons springs or streams due to hill-cut operations
- Disruption to services such as water supply, power supply due to utility relocation and/or at times due to construction activities
- Disruption to access to private houses /properties during construction activities, temporarily;
- Disruption to traffic movement leading to time delays;
- differential impacts on vulnerable and disadvantaged population
- Dust emissions during construction leading to impacts on community health, crops and trees
- Likelihood of accidents due to road construction works;
- Possibility of gender-based violence arising from influx of migrant construction workers;
- Possibility of HIV/AIDS, among construction workers and roadside community;

4.3 Operation Stage

36. The ESMP measures during operation phase largely include environmental monitoring, upkeep and maintenance of nature-based bio-engineering solutions along project road. This shall be carried out by the contractor appointed for the maintenance contract.

Table 4-1: Environment and Social Management Plan – Environmental Impacts

S. No	Project Stage/Activity	Mitigation Management Measures/GIP Measures	Responsibility	
			Planning and Execution	Supervision/ Monitoring
PRE-CONSTRUCTION ACTIVITIES BY CSC and HPRIDCL				
1	Permission for Tree Felling	<ul style="list-style-type: none"> The project road does not require any prior environmental clearances. Only permission for felling of trees, which are within the right of way shall be required from Department of Forests, GoHP. The application for tree permissions shall be made well in advance and no site clearance or pre-construction activities shall be initiated in stretches, which involve tree felling. Coordinate and ensure timely felling of trees through the Forest Department, including removal of all stubs and clearance of site. Undertake, any stipulations imposed by the Department of Forests, while issuing the tree felling permissions including compensatory plantation among others Prioritize the stretches for handing over to the contractor for commencement of construction 	Environment & Social Specialists of CSC for the Construction Package	Environmental Specialist of HPRIDCL under the overall guidance of Project Director
2	Clearance of encumbrances within RoW (Encroachments by non-title holders and squatters)	<ul style="list-style-type: none"> Ensure all encroachments within right of way by title and non-titleholders are removed, after disbursement of compensation, duly in accordance with RPF/RAP under HPSRTP through an NGO appointed by HPRIDCL for implementation of RAP for the project corridors. No encroachments shall be removed, prior to disbursement of entitlements and in case of any grievances, same shall be redressed, prior to removal of encroachment Ensure all grievances of PAHs/PAHs are received and are resolved in accordance with established GRM The compensation and removal of private assets within the CoI, shall be in accordance to resettlement policy framework applicable to HPSRTP and as per the Resettlement Action Plan prepared for this specific corridor. As per the RAP, encroachers & squatters shall be paid due entitlements (compensation and assistances) and shifted out of COI. Relocation of impacted CPRs shall be carried out as per the RPF provisions. Prioritize the stretches for handing over to the contractor for commencement of construction 	NGO for RAP implementation and Environment & Social Specialists of CSC for the Construction Package assisted by Revenue Department as required	Environmental Specialist of HPRIDCL under the overall guidance of Project Director
3	Relocation of Community Utilities and Common Property	<ul style="list-style-type: none"> Ensure all utility utilities, which are within Right of way like water supply pipelines, electric poles, transformers, telephone poles etc. in accordance with encumbrance removal plan and close coordination with respective line departments. Prioritize the stretches for handing over to the contractor for commencement of construction 	NGO for RAP implementation and Environment & Social Specialists of CSC for the Construction Package in co-	Environmental Specialist of HPRIDCL under the overall guidance of Project Director

S. No	Project Stage/Activity	Mitigation Management Measures/GIIP Measures	Responsibility	
			Planning and Execution	Supervision/ Monitoring
			ordination with line departments as required	
PRE-CONSTRUCTION ACTIVITIES BY CONTRACTOR AND CONSTRUCTION SUPERVISION CONSULTANTS (CSC)				
4	ESHS Performance Requirements under the Contract	<ul style="list-style-type: none"> The ESHS (Environment, Social, Health and Safety) performance requirements by the contractor under contract have been specified and incorporated as special conditions and performance requirements in all bid documents of contract packages (ref. Appendix-11). Adequate cost provisions for implementation of ESHS requirements are included in the item rates, so that contractor can perform requirements in a fair and objective manner. Provision of 2% of contract amount has been earmarked as ESHS performance security in the bidding documents. Thus, the contractor is expected to be fully aware of ESHS performance requirements at the bidding stage and accordingly deemed to have priced the performance requirements at the bidding stage itself. The ESHS performance requirements incorporated in the bid documents, obligate the contractor, upon mobilization, to prepare a Contractor's ESMP (C-ESMP), which shall include impacts mitigation and management plan, environmental enhancement plan, OHS plan, labor management plan, labor Influx management Plan, workers' campsite management plan, GRM for workers' traffic management and road safety management plan, COVID-19 considerations and among others in accordance with the GoI, GoHP, IFC & WB requirements. The C-ESMP submitted by the contractor shall be reviewed in consultation with HPRIDCL and approved by the CSC, prior to commencement of construction works. The approved C-ESMP also be reviewed periodically (as and when required but at least once in three (3) months) by CSC and updated in a timely manner, to address changed requirements, if any during project implementation. 	Contractor	<p><u>Supervision:</u> Environment & Social Specialists of CSC</p> <p><u>Monitoring:</u> Environmental Specialist of HPRIDCL under the overall guidance of Project Director</p>
5	Disaster Management & Emergency Response Plan	<ul style="list-style-type: none"> As part of C-ESMP, Contractor shall prepare Disaster Management and Emergency Response Plan at the project road level and same shall be review and approved by CSC. The ERP at project road construction level in an event of climate change induced natural disasters and/or any other natural calamities shall comprise the following: <ul style="list-style-type: none"> In order to ensure the safety of work force at operational sites and safe evacuation of workforce in the event of natural disaster and/or any other natural calamities, the project road construction contractor shall have an emergency response plan (ERP). As part of the ERP, the project contractor shall establish and maintain regular coordination 	Contractor	<p><u>Supervision:</u> Environment & Social Specialists of CSC</p> <p><u>Monitoring:</u> Environmental Specialist of HPRIDCL under the</p>

S. No	Project Stage/Activity	Mitigation Management Measures/GIIP Measures	Responsibility	
			Planning and Execution	Supervision/ Monitoring
		<p>with the designated officers for Disaster Management at district/sub-division levels. Maintaining regular coordination will enable to seek quick response, in the event of natural disaster and/or any other natural calamity.</p> <ul style="list-style-type: none"> ○ Mandi district has a Disaster Management Plan at district and subdivision level, which provide the institutional arrangements, designated officers, emergency response systems, infrastructure facilities like hospitals, fire stations, police station at tehsil, sub-division and village levels. ○ All project operations shall be planned and coordinated in tandem with the daily/weekly weather predictions/alerts issued by competent authorities as relevant for the district/ project road and all such alerts shall be duly considered and review the scheduled work programs on a daily basis. ● At project level, contractor shall designate an Incident Controller (IC), Emergency Controller (EC), Assembly Coordinator (AC) and other required personnel for the emergency response mechanism in an event of natural disaster/ calamity in line with the ERP. ● The preparation and implementation of ERP shall form a part of C-ESMP of the contractor and checked and approved by the CSC. ● All work force irrespective of levels are to be provided with training and periodic mock drills to ensure the preparedness for any emergency situations, always in short notice. ● The local community along project road shall also be engaged in mock drills for proactive participation in case of any natural hazards or disaster/ calamity. ● A template for the Disaster Management and Emergency Response Plan has been included in Appendix-17 of ESMP volume, which may be further updated suiting to requirements of contractor's scale of establishment after the mobilization. 		overall guidance of Project Director
6	Work Zone Safety Requirements	<ul style="list-style-type: none"> ● Prior to commencement of construction, the contractor will prepare and submit Contractor's ESMP (C-ESMP), which will include contractor's management plan to comply with the project's safeguard requirements and Management Strategies and Implementation Plans (MSIPs) for (i) Work Management; (ii) traffic and work zone safety management plan for the prioritized encumbrance free stretches, in accordance with approved implementation schedule. ● In addition, the contractor will be contractually obligated to implement work zone safety arrangements conforming to the requirements of IRC: 67 and IRC: SP: 55: 2014, which include provision of PPEs, fixed/ mobile barricades between work area and pedestrian/ traffic and required measures for ensuring community safety during construction activities. 	Contractor	<p><u>Supervision:</u> Environment & Social Specialists of CSC</p> <p><u>Monitoring:</u> Environmental Specialist of HPRIDCL under the overall guidance of Project</p>

S. No	Project Stage/Activity	Mitigation Management Measures/GIIP Measures	Responsibility	
			Planning and Execution	Supervision/ Monitoring
		<ul style="list-style-type: none"> The requirements also include site specific traffic management plan for all types of works along with work zone safety check list. A typical diagram showing traffic management during construction phase as shown in Figure 3-1 Section 3 and an illustrative checklist for work zone safety is given in Appendix-18 of ESMP volume. The responsibility of contractor to manage these risks is clearly reflected in the contractual obligations of the Civil Works Contractor with appropriate mechanisms for addressing non-compliance. The bid documents for construction will incorporate requirements for Environment, Social, Health and Safety (ESHS) including list of applicable labor laws and community safety provisions for periodic reporting by contractors. Commencement of any activity by contractor without prior approval of these requirements will be treated as a fundamental breach of contract. The C-ESMP will be approved by the CSC, prior to the commencement of construction activities, will be periodically reviewed by CSC (but not later than every 3 months) and updated in a timely manner by the Contractor, to ensure that it contains appropriate measures for the work zone and community safety throughout construction phase 		Director
7	Orientation and submission of C-ESMP by contractor	<p>Contractor is to be oriented with the ESMP stipulations and ESHS requirements under the contract as well as ESS requirements of the World Bank (ref. Appendix-9). This shall include but not limited to the following</p> <ul style="list-style-type: none"> Contractual Obligations of the Contractor to submit Contractor's C-ESMP Environmental and Social Management Plan Regulatory compliance requirements like obtaining CTE and CTO from State Pollution Control Board Establishing GRM (Grievance Redress Mechanism) for Contractor's workforce as well as for community members for social and environmental issues Implementation of various plans required under C-ESMP related to Occupation Health & Safety (OHS), traffic and road safety, community health and safety (CHS), hazardous and non-hazardous waste management plan, camp site management, emergency response plan ERP) including conducting periodic mock drills, opening up of borrow area and muck disposal and including their restoration plan etc. Workforce/Labour Management Procedures in line with HPRIDCL's LMP Procedures for Worker's safety at all operational sites Implementation of GBV risk mitigation strategy plan at workforce camps, operational sites and 	Contractor Orientation by	<p><u>Supervision & Orientation by:</u> Environment & Social Specialists of CSC</p> <p><u>Monitoring:</u> Environmental Specialist of HPRIDCL under the overall guidance of Project Director</p>

S. No	Project Stage/Activity	Mitigation Management Measures/GIIP Measures	Responsibility	
			Planning and Execution	Supervision/ Monitoring
		<p>at other hotspots likely to be frequented by workers after work hours/leisure and/or on weekly off days</p> <ul style="list-style-type: none"> Stakeholder Engagement <p>Contractor shall appoint one Environmental Officer, one Social-cum-Community Liaison Officer and one Health and Safety Officer, who shall be solely be responsible for implementation of all the ESMP stipulations and ESHS requirements under the contract as well as ESS requirements of the World Bank in close co-ordination/consultation with Environmental and Social Specialists under CSC and HPRIDCL.</p> <p>The contractor shall be required to submit contractor's C-ESMP, which shall include OHS plan, Water and Waste Management Plan, Workforce Influx management Plan, Worker's camp management plan, CHS Plan, Transport (or road safety) management Plan, Quarry/borrow area management plan, establishment of GRM for labour and Site restoration Plan among others in accordance with the GoI and/or IFC/WB workers accommodation guidelines.</p> <p>Some of the GRM dissemination avenues for construction workers are;</p> <ul style="list-style-type: none"> During Induction training for new workers During Toolbox meet/briefings by work supervisors During periodic tail gate sessions, to review and refresh site protocols on safety procedures at work Through pictorial illustrations and posters in local language installed at prominent places like entry/exit points, canteen, entertainment areas, health camps sites etc. During awareness campaigns for safety at work and response to Emergency Response Plans Awareness and briefing on community safety, while at work <p>All C-ESMPs prepared by Contractor covering all above-mentioned aspects shall be reviewed in consultation with HPRIDCL and approved by the CSC prior to commencement of construction works.</p>		
8	COVID - 19 Requirements for Contract Workers with Particular Reference to Migrant Construction	<ul style="list-style-type: none"> In respect of COVID situation, Standard Operating Procedures (SOPs) and Guidelines for Construction Sites for COVID-19 Outbreak issued by Central Public Works Department, Government of India, May 2020 and HP State Government order issued on May 2, 2020 by Govt. of HP under clause 3 of the Himachal Pradesh Epidemic Disease (COVID 19) Amendment regulations 2020 and all related notifications, as & when notified and applicable to Project Road. Contractor shall mandatorily adhere to these GoHP and GoI COVID -19 SOPs at all 	Contractor	<p><u>Supervision:</u> Environment & Social Specialists of CSC</p> <p><u>Monitoring:</u></p>

S. No	Project Stage/Activity	Mitigation Management Measures/GIIP Measures	Responsibility	
			Planning and Execution	Supervision/ Monitoring
	Workers	<p>construction sites, which shall cover all contract workers, particularly migrant construction workers during the mobilization and subsequent phases of construction by the contractor:</p> <ul style="list-style-type: none"> É Induction of new batch of migrant workers, possibly some of them could be symptomatic or asymptomatic COVID carrier(s) É Migrant workers returning to work after visiting native places and/or hometowns, possibly asymptomatic COVID carriers and could have got infected either on way home or on way back to project site É Any worker, who could have got infected from local community during visit to local market areas for purchase of some daily-needs É Contractor shall adopt Labour Management Procedure in line with LMP of HPPRIDC and shall submit to CSC É Details in writing of the measures being taken to address the risks and SOPs that cover the following aspects <ul style="list-style-type: none"> a. Conducting pre-employment health checks b. Controlling entry and exit from site/workplace c. General hygiene, cleaning and waste disposal at all operational sites d. Maintaining social distance of minimum 1.5 meter at work sites as well as at workforce camps e. Provision of PPEs for covering of face with masks/cotton cloths, use of sanitizers, frequent washing of hands f. Creating awareness and prohibiting spitting in public, avoid use of chewing gum, tobacco in all forms, g. Instruct/encourage reporting of flu-like-illness symptoms and creation of isolation/quarantine rooms for any workers reporting/showing COVID symptoms until shifting to designated COVID hospitals h. Adjusting work practices from COVID consideration i. reviewing accommodation arrangements maintain social distancing norms j. reviewing accommodation arrangements, to see if they are adequate and designed to reduce contact with the community k. reviewing contract durations, to reduce the frequency of workers entering/exiting the site l. rearranging work tasks or reducing numbers on the worksite to allow social/physical 		Environmental Specialist of HPRIDCL under the overall guidance of Project Director

S. No	Project Stage/Activity	Mitigation Management Measures/GIIP Measures	Responsibility	
			Planning and Execution	Supervision/ Monitoring
		<p>distancing, or rotating workers through a 24-hour schedule</p> <p>m. providing appropriate forms of personal protective equipment (PPE)</p> <p>n. putting in place alternatives to direct contact, like tele-medicine appointments and live stream of instructions.</p> <p>o. Instances of spread of virus</p> <p>p. Training and communication with workers</p> <p>q. Communication and contact with community</p> <p>É Provision of medical insurance covering treatment for COVID-19, sick pay for workers who either contract the virus or are required to self-isolate due to close contact with infected workers and compensation payment in the event of death</p> <p>É Designating/appointing a COVID-19 focal point officer with responsibility for monitoring and reporting on COVID-19 issues and liaising with competent authorities designated by district administration or the State Government.</p> <p>É Contractor to convene regular meetings with the project health and safety specialists and medical staff (and where appropriate with local health authorities), and to take their advice in designing and implementing the agreed measures.</p> <p>É Identify a senior person as a focal officer with responsibility for monitoring and reporting on COVID-19 issues and liaising with competent authorities designated by the district administration or State Government authorities point</p> <p>É Contractor's coordination arrangements, particularly at site where there are a number of contractors and therefore (in effect) different work forces (CSC could request the main contractor to put in place a protocol for regular meetings of the different contractors)</p> <p>É Contractors to ensure regular checks on whether the workers are informed/encouraged to use the existing project grievance mechanism to report concerns relating to COVID-19</p> <p>The monitoring of performance of contractors including the implementation of C-ESMP and meeting the ESHS performance requirements by the contractor shall be overseen and managed by the CSC under the overall guidance and direction of Project Director.</p>		
9	Joint Field Verification	<ul style="list-style-type: none"> The contractor shall carry out joint field verification with CSC to ascertain any possibilities of saving trees, protection/preservation of community resources, prior to commencement of construction by the construction Contractor 	Contractor	<p><u>Supervision:</u> Environment & Social Specialists of CSC</p> <p><u>Monitoring:</u></p>

S. No	Project Stage/Activity	Mitigation Management Measures/GIIP Measures	Responsibility	
			Planning and Execution	Supervision/ Monitoring
				Environmental Specialist of HPRIDCL under the overall guidance of Project Director
10	Crushers, Hot-mix Plants and Batching Plants Location	<ul style="list-style-type: none"> All establishments/facilities by the contractor shall be set up sufficiently, away from settlements and agricultural lands or any commercial establishments. Such facilities shall preferably be located at least 500 m away from forest, water bodies, and sensitive receptors like hospital, schools, temples and the nearest dwelling preferably in the downwind direction. The Contractor shall submit a detailed layout plan for all such site establishments and prior approval of CSC shall be necessary. Site specific protection measures required at such location are to be considered to minimize associated environmental and social risk, if the site selection is in rolling terrain. Arrangements to control dust pollution through provision of wind Screens, water sprinklers, and dust extraction systems shall have to be provided at pollutant sources in all such operational sites. For dust suppression, water sprinkling is to be done as per requirements so as to ensure that there are no visible dust levels at any establishment sites and /or operational sites. The crushers, hot mix plants and batching plants shall conform the emission norms as well as noise level limits stipulated by CPCB and/or HPSPCB Consent to Establish (CTE) and Consent to Operate (CTO) shall be obtained from HPSPCB by the Contractor prior to establishing or operation of any such facilities under this contract. A copy of permissions/consents should be submitted to CSC. The contractor shall carry out periodical environmental monitoring at each of these locations/ operational sites as per Monitoring Program in ESMP and/or HPSCB norms and shall also carry out necessary servicing/ repair/ maintenance of machineries and equipment to comply with permissible emission standards for air and noise of GoI and GoHP. 	Contractor	<p><u>Supervision:</u> Environment & Social Specialists of CSC</p> <p><u>Monitoring:</u> Environmental Specialist of HPRIDCL under the overall guidance of Project Director</p>
11	Deployment of Construction Vehicles, Equipment and Machinery	<ul style="list-style-type: none"> All vehicles, equipment and machinery deployed for construction shall conform to the relevant emission norms. The applicable standards under the Environment Protection Act, 1986 and Motor Vehicles Act, (Amendment) 2019 shall be strictly adhered to. The Contractor shall maintain a record of Pollution Under Control (PUC) certificates for all vehicles and machinery used during the contract period which shall be submitted to CSC for verification, whenever required. 	Contractor	<p><u>Supervision:</u> Environment & Social Specialists of CSC</p> <p><u>Monitoring:</u> Environmental Specialist</p>

S. No	Project Stage/Activity	Mitigation Management Measures/GIIP Measures	Responsibility																															
			Planning and Execution	Supervision/ Monitoring																														
		<ul style="list-style-type: none"> The contractor shall maintain record and conduct fitness test of all vehicles and machinery at regular interval of one year and fitness certificated shall be submitted to CSC. Only fit vehicles and machinery shall be deployed during construction. All vehicles and machinery used during construction should be well maintained and conform to currently applicable emission norms. 		of HPRIDCL under the overall guidance of Project Director																														
IDENTIFICATION AND SELECTION OF MATERIAL SOURCES																																		
12	Selection and Management of Borrow Areas	<ul style="list-style-type: none"> The Contractor shall not open any new borrow area without obtaining Environmental Clearance (EC) from DEIAA as required under EIA notification 2006 as amended for minor mineral on 15th Jan 2016(ref. Appendix-1). The CSC's approval for contractor's proposed borrowing of area shall be mandatory along with other required statutory requirements. No borrow area shall be operated in forest and agriculture land, and near to water bodies. If identified borrow area land belongs to Govt, then contractor shall obtain a prior approval from respective government department/authorities. The Contractor shall not start borrowing earth from selected borrow areas until formal agreement is signed between landowner and Contractor and Borrow Area management and redevelopment plan is submitted and approved by CSC. The operation of borrow area shall strictly adhere to approved borrow area management and redevelopment plan. Avoid construction of new haul roads for accessing borrows areas, to the extent possible. Preference shall be given for using of existing roads, wherever possible. The contractor may decide on using of identified potential borrow area locations, after complying aforementioned requirements. Following are the identified potential borrow area locations and contractor may or may not use these based on its requirement and ease of obtaining requisite permissions for borrowing earth thereof from respective Government Departments. <table border="1"> <thead> <tr> <th>Borrow Area</th> <th>Chainage (km)</th> <th>Lead (m)</th> <th>Side (LHS/RHS)</th> <th>Ownership Details</th> <th>Available Quantity</th> </tr> </thead> <tbody> <tr> <td>BA-1</td> <td>10+500</td> <td>20</td> <td>LHS</td> <td>Government</td> <td>Hill (Adequate)</td> </tr> <tr> <td>BA-2</td> <td>15+230</td> <td>20</td> <td>LHS</td> <td>Government</td> <td>Hill (Adequate)</td> </tr> <tr> <td>BA-3</td> <td>22+000</td> <td>20</td> <td>LHS</td> <td>Government</td> <td>Hill (Adequate)</td> </tr> <tr> <td>BA-4</td> <td>27+000</td> <td>20</td> <td>RHS</td> <td>Government</td> <td>Hill (Adequate)</td> </tr> </tbody> </table>	Borrow Area	Chainage (km)	Lead (m)	Side (LHS/RHS)	Ownership Details	Available Quantity	BA-1	10+500	20	LHS	Government	Hill (Adequate)	BA-2	15+230	20	LHS	Government	Hill (Adequate)	BA-3	22+000	20	LHS	Government	Hill (Adequate)	BA-4	27+000	20	RHS	Government	Hill (Adequate)	Contractor	<p><u>Supervision:</u> Environment & Social Specialists of CSC</p> <p><u>Monitoring:</u> Environmental Specialist of HPRIDCL under the overall guidance of Project Director</p>
Borrow Area	Chainage (km)	Lead (m)	Side (LHS/RHS)	Ownership Details	Available Quantity																													
BA-1	10+500	20	LHS	Government	Hill (Adequate)																													
BA-2	15+230	20	LHS	Government	Hill (Adequate)																													
BA-3	22+000	20	LHS	Government	Hill (Adequate)																													
BA-4	27+000	20	RHS	Government	Hill (Adequate)																													

S. No	Project Stage/Activity	Mitigation Management Measures/GIIP Measures	Responsibility	
			Planning and Execution	Supervision/ Monitoring
		<ul style="list-style-type: none"> The CSC shall inspect every borrow area location(s) prior to approval. The CSC shall include the Request for Inspection form for approving opening and restoration of borrows area from the environment and safety considerations. 		
13	Selection and Management of Quarry and its Operations	<ul style="list-style-type: none"> The contractor shall prepare a Quarry Management Plan, which shall include an assessment on use of existing quarries and identify plans to be prepared to comply with provisions in project ESMP, which shall be part of Quarry Management Plan to be submitted for approval of CSC. The CSC shall include the Request for Inspection form for approving opening and closing of quarry area from the environmental angle(ref. Appendix-2). The contractor's Quarry Management Plan shall include <ul style="list-style-type: none"> a) Existing Quarry <ul style="list-style-type: none"> The Contractor's Environmental Officer shall submit a due diligence report of existing quarries compliance with respect to applicable statutory requirements, identify and measures to offset risk to the project, if any required. The existing quarry shall have to comply with project ESMP such as OHS of workers, fugitive dust control measures during transportation and at stock piling, stockpile management and any other anticipated risks. b) New quarry <ul style="list-style-type: none"> The Contractor shall not open any new quarry area without obtaining Environmental Clearance (EC) from DEIAA as required under EIA notification 2006 as amended for minor minerals of 15th Jan, 2016 and The Mines and Minerals (Development and Regulation) Act 1957. The contractor shall submit the quarry management plan and stipulated conditions for approval of quarry site by Mining Department along with details of approved locations for establishing quarry and crusher operations. Consent to Establish (CTE) and Consent to Operate (CTO) from HPSPCB shall be obtained by the Contractor before establishment and operation of quarry/crushers, A copy of permissions should be submitted to the CSC. The quarry management plan shall comply with project ESMP such as OHS of workers, establishment of workers accommodations, waste management, fugitive dust control during transportation and at stock piling, waste water and sanitary waster from workers camps, storage of fuel, stockpile management and any other anticipated risks shall be part of Quarry Management Plan. 	Contractor	<p><u>Supervision:</u> Environment & Social Specialists of CSC</p> <p><u>Monitoring:</u> Environmental Specialist of HPRIDCL under the overall guidance of Project Director</p>

S. No	Project Stage/Activity	Mitigation Management Measures/GIIP Measures	Responsibility	
			Planning and Execution	Supervision/ Monitoring
14	Arrangement for Construction Water	<ul style="list-style-type: none"> The contractor shall be responsible to arrange project's water demand in compliance to requisite statutory requirements. In doing so, the contractor shall assess water source availability and shall prepare a project's water budget and management plan for approval of CSC. To avoid disruption/disturbance and stressing of other water sources like springs and seasonal streams used by the communities, the contractor shall submit list of fixed water sources identified for extracting water with requisite approvals, wherever required to CSC. To meet daily water requirements of water, Contractor shall prepare and implement the approved water management plan in accordance with the Appendix-3 of ESMP document. The Contractor shall use ground water as a source of construction water and may set up own bore wells. Constructing new bore well shall be in compliance with the requirements of the designated State Govt. Department and/or Irrigation and Public Health Department (IPH) for ground water extraction. The contractor shall submit a copy of the permission to CSC. The contractor may choose to construct water harvesting structure, wherever feasible along road to meet demand of water during construction. Prior approvals for such harvesting shall be taken and submitted to CSC. 	Contractor	<p><u>Supervision:</u> Environment & Social Specialists of CSC</p> <p><u>Monitoring:</u> Environmental Specialist of HPRIDCL under the overall guidance of Project Director</p>
15	Labour Requirements and Labour Management Procedure	<ul style="list-style-type: none"> Contractor shall comply with all labour regulations of GoHP, Government of India/IFC and World Bank including the LMP of HPRIDCL and Draft code on Occupational Safety Health and working conditions code, 2019, GoI(ref. Appendix-15). Contractor Shall prefer skilled /unskilled local labour drawn from nearby places/ region wherever feasible/extent possible, to benefit local community. 	Contractor	<p><u>Supervision:</u> Environment & Social Specialists of CSC</p> <p><u>Monitoring:</u> Environmental Specialist of HPRIDCL under the overall guidance of Project Director</p>
16	Arrangements for Temporary Land Requirement	<ul style="list-style-type: none"> Contractor shall carry out negotiations with the landowners for obtaining their consent for temporary use of lands for construction camp/ borrow areas/Debris Disposal Area etc. and honor all local rules in this regard. 	Contractor	<p><u>Supervision:</u> Environment & Social Specialists of CSC</p> <p><u>Monitoring:</u> Environmental Specialist of HPRIDCL under the</p>

S. No	Project Stage/Activity	Mitigation Management Measures/GIIP Measures	Responsibility	
			Planning and Execution	Supervision/ Monitoring
				overall guidance of Project Director
CONSTRUCTION STAGE				
17	Workers Orientation and Sensitization Training	<ul style="list-style-type: none"> All work force of the Contractor shall be subjected to an orientation program, which familiarize them with work requirements, safety practices at work, safe distances to keep from earth moving equipment, first aid facilities, emergency response, on-site sanitation facilities and practices to be adopted, rights and privileges of workforce among others. The orientation shall be carried on Induction, at the start of the day for work through toolbox meetings and tailgate sessions Orientation shall also include concern for community safety around operational sites/areas as well, Orientation shall also include first aid facilities, emergency care and emergency response plan available at operational sites and at workforce camps shall be provided to all workforces. 	Contractor	<u>Supervision:</u> Environment & Social Specialists of CSC <u>Monitoring:</u> Environmental Specialist of HPRIDCL under the overall guidance of Project Director
18	Clearing and Grubbing	<ul style="list-style-type: none"> Vegetation shall be removed from the construction zone before commencement of construction. All works shall be carried out such that the damage or disruption to flora other than those identified for minimum cutting/ clearing. Only ground cover/shrubs that impinge directly on the permanent works or necessary temporary works shall be removed with prior approval from CSC. The Contractor, under NO circumstances shall be cut or damage trees and forest reserves. Trees identified under the project shall be cut only after receiving clearance from the Forest Department and after the receipt of CSC written permission in this regard. 	Contractor	<u>Supervision:</u> Environment & Social Specialists of CSC <u>Monitoring:</u> Environmental Specialist of HPRIDCL under the overall guidance of Project Director
19	Stripping, Stocking and Preservation of Topsoil	<ul style="list-style-type: none"> The topsoil from all areas of cutting and all areas to be permanently covered shall be stripped off to a specified depth of 150 mm and stored in stockpiles. The contractor shall earmark temporarily land area and/or Right of Way for storing topsoil. The locations for stock piling shall be pre-identified in consultation and with approval CSC. The contractor shall take measures to prevent generation of dust from such stockpile areas by covering or retaining soil moisture. In addition to taking erosion preventive measures, stripping activity shall not be planned or scheduled during monsoon period. Such stockpiled topsoil shall be utilized for ó 	Contractor	<u>Supervision:</u> Environment & Social Specialists of CSC <u>Monitoring:</u> Environmental Specialist of HPRIDCL under the overall guidance of Project

S. No	Project Stage/Activity	Mitigation Management Measures/GIIP Measures	Responsibility	
			Planning and Execution	Supervision/ Monitoring
		<ul style="list-style-type: none"> ○ To prepare surface for bioengineering measures. ○ Covering all disturbed areas including borrow areas ○ Dressing of slopes of road embankment ○ Agricultural fields of farmers acquired temporarily land, if so desired by such landowners. 		Director
20	Construction Camp Site Offices, Material Stack Yards, Hot Mix Plants, Batch Mix Plants for WMM and Concrete, Workforce Camps Locations - Selection, Design and Lay-out	<ul style="list-style-type: none"> • Contractor's Environmental Officer and Health and Safety Officer in consultation and with requisite approvals from Gram panchayat and/or private land owners shall identify suitable lands, which can be used as material stack yards and work camp sites for establishing macadam mix plants, hot mix plants and storage of construction materials by the contractor during construction phase. The contractor shall submit to CSC the lease agreement with private/community/government owner for setting up campsites at suitable locations along road alignment and shall mandatorily restore to its previous state after completion of road construction works(ref. Appendix-4). • The contractor shall submit location specific lay-out plan of all temporary establishment with details of facilities proposed for approval of CSC. No temporary establishments shall be operated without consent of CSC. • Preferably barren lands or uncultivable lands and those away from human settlements shall be the given preference, while selecting and establishing work camp sites. Also, these shall be at least 500m distance away from forest areas and water bodies. The selected land shall not warrant significant change in landforms or terrain, to make it suitable for establishing work camp sites/store yards. In case, land had been earlier used for establishing work camp site and meets the above requirements, same shall be given preference. • If private land (s) has been identified, no site clearing operations shall commence without a written lease agreement. The agreement with landowner shall clearly state the lease duration, compensation for the agreed lease period, site restoration plan as desired/required by the landowner and any other condition mutually agreed upon between contractor and landowner. In case agricultural land have been chosen with no alternatives, then topsoil (30-45 cm deep) shall be collected and stored in an access-controlled area and covered with net cloth. Regular sprinkling of water in pressurized fine spray shall be done to prevent blowing away of soil. • The contractor shall be responsible to provide any mitigation and management measures to prevent induced impacts from such establishment due to waste water, solid waste, landslide, erosion, clogging of streams, soil and water contamination, spoil dumping etc. Any claims or complaints arising due to contractor actions shall be addressed in amicable way at their own cost. 	Contractor	<p><u>Supervision:</u> Environment & Social Specialists of CSC</p> <p><u>Monitoring:</u> Environmental Specialist of HPRIDCL under the overall guidance of Project Director</p>

S. No	Project Stage/Activity	Mitigation Management Measures/GIIP Measures	Responsibility	
			Planning and Execution	Supervision/ Monitoring
		<ul style="list-style-type: none"> • Requisite consent to establish and consent to operate shall be obtained from HPSPCB. All stipulated consent conditions by HPSPCB shall be strictly adhered and complied by contractor. The work camp sites shall be access controlled with fixed entry and exit points. • The dust levels at the work camps sites shall be controlled through regular sprinkling of water through similar mobile tankers deployed at operational areas for road construction. Bitumen mix plants, Batch mix plants deployed for road construction shall conform to regulatory norms/requirements. • The site shall be cleared from all remnants of construction and debris and site restored to its previous state, prior to handing the site to the owner. • The work camp sites shall mandatorily have designated paved areas with shades/roof for storage of used oils/lubes in plastic/HDPE drums, prior to their final disposal in HPSPCB approved disposal locations. • Provision of one mobile toilet of 2-seater capacity (1 men and 1 woman with separate entrances) shall be stationed at a suitable place within 100 meters from each operational area. The mobile toilet shall have at least 1000 liters overhead water storage, well always maintained and in usable condition. Bottom tanks shall be regularly cleaned, and overhead tank replenished as per requirement. • Work force shall be oriented to use mobile toilets and avoid using public toilets and/or nearby open places/parks. • Every operational area shall be provided with one mobile drinking water kiosk having a storage of 300 liters and placed at a suitable place within 100 meters from work site. • All work force shall be provided with suitable type of accommodation, if required and local labour or can return to their normal places of residence. Pooled transportation facilities as may be required, shall be provided by contractor. If establishing workforce camps become utmost necessary, then same shall be established at least 500m away from the settlement areas and away from bridge sites and or any other water body. • The camp site shall be restored to its previous state or as agreed upon with the landowner prior to establishing the workforce camp. • The workforce camps shall be provided with all basic facilities like water supply, cooking gas facility, sanitation facilities including provision of mobile toilet (of adequate seating capacity for men and women separately) shall be stationed within the workforce camp. The mobile toilet shall be periodically replenished with fresh water for ablution purposes and waste water shall 		

S. No	Project Stage/Activity	Mitigation Management Measures/GIIP Measures	Responsibility																
			Planning and Execution	Supervision/ Monitoring															
		<p>be emptied through suction tankers and carried to the nearest municipal sewage treatment facilities. Alternatively, septic tank cum soak pit arrangements of adequate capacity shall be provided as per requirements.</p> <ul style="list-style-type: none"> No wastewater from the camp/work force site shall be discharged directly without any treatment in to any surface water channels or drain, which eventually join surface water bodies. The camp sites shall have 4 numbers of septic tank (each 5m Length, 2m Breadth and 1.5 m Clear depth with 0.3 free board) with soak pit arrangement which can serve for work force at peak level as per CPWD specifications. 																	
21	Earth / Rock excavation and Disposal of Muck/Construction Debris	<ul style="list-style-type: none"> The site clearance and/or excavation activities shall be opened up only in segments of 250 m stretch at a time and no new stretches shall be opened up unless the clearance and/or excavation activities in previous stretches been satisfactorily completed and clearance given for the opening of next stretch by CSC(ref. Appendix-5). Prior to undertaking any site clearance and/or excavation activities, particularly hill side cut and excavation activities in any working stretch, the contractor shall mandatorily prepare an excavation plan with site specific measures/plans to comply with project's ESMP and C-ESMP. The contractor through Request for Inspection form shall submit excavation plan to CSC for approval in advance before opening of new work zone i.e., 250m for approval of CSC. Stability of slopes, natural and man-made, is important for a hill road. The hill cut operations during project road construction can potentially disturb the hill slopes, in addition to other causative factor like, erosion by rainfall and runoff, surcharge etc. The adverse impacts can be minimized by regulating slope cuts along the hill faces. The recommended safe cut slopes are given hereunder: <p style="text-align: center;">Recommended Slope cuts for Hillside along Project Road</p> <table border="1" style="margin-left: auto; margin-right: auto;"> <thead> <tr> <th>S. No</th> <th>Type of Material</th> <th>Recommended Slope cuts</th> </tr> </thead> <tbody> <tr> <td>1</td> <td>Loose Soil and Vulnerable Geology</td> <td>2V: 1H</td> </tr> <tr> <td>2</td> <td>Compacted Soil with Slope towards Road</td> <td>4V: 1H</td> </tr> <tr> <td>3</td> <td>Soft Rock</td> <td>6V: 1H</td> </tr> <tr> <td>4</td> <td>Hard Rock</td> <td>8V: 1H</td> </tr> </tbody> </table> Blasting and use of explosives in any form shall not be used by the contractor under any 	S. No	Type of Material	Recommended Slope cuts	1	Loose Soil and Vulnerable Geology	2V: 1H	2	Compacted Soil with Slope towards Road	4V: 1H	3	Soft Rock	6V: 1H	4	Hard Rock	8V: 1H	Contractor	<p><u>Supervision:</u> Environment & Social Specialists of CSC</p> <p><u>Monitoring:</u> Environmental Specialist of HPRIDCL under the overall guidance of Project Director</p>
S. No	Type of Material	Recommended Slope cuts																	
1	Loose Soil and Vulnerable Geology	2V: 1H																	
2	Compacted Soil with Slope towards Road	4V: 1H																	
3	Soft Rock	6V: 1H																	
4	Hard Rock	8V: 1H																	

S. No	Project Stage/Activity	Mitigation Management Measures/GIIP Measures	Responsibility													
			Planning and Execution	Supervision/ Monitoring												
		<p>circumstances. All rock excavation/ hill cutting operations shall be carried out using the rock driller/ hammer attachments with the excavators.</p> <ul style="list-style-type: none"> • Prior to commencement of any such rock excavation operations, contractor shall inspect the site to assess the potential for any disturbance to the adjoining houses/ properties and undertake the works in slow pace with prior intimation to such property owners. • The excavation plan shall include detail estimated volume of material to be cut or excavated, details of approved disposal sites, arrangements made for transport of excavated material to the approved disposal sites, dust suppression measures at excavation site and along transportation routes, method of stacking and/or handling the excavated material at the disposal site, health and safety measures, road safety and traffic management, slope stability and erosion and emergency response etc. • The contractor's handling and management of surplus excavation material through a Muck Disposal Plan. The site-specific Muck Disposal Plans so prepared shall be reviewed and approved by CSC and shall be mandatory for opening and commencement of excavation or hill side cutting at new work zone or stretch. • The site-specific Muck Disposal Plan shall essentially include <ul style="list-style-type: none"> ○ Agreement with landowner ○ On a contour map record land area, boundary limits, existing and surrounding environmental settings, but not limited to topography, drainage, water bodies, settlements, trees, haul road etc. and identify likely environmental risk and safety hazards. ○ The details of mitigation measures shall include both engineering (toe wall, gabion wall) and non-engineering measures (benching, nature-based bio-engineering solutions) ○ Restoration plan of the muck disposal site • The construction debris from all operational areas shall be regularly scavenged and disposed off at disposal sites identified under the project or those approved by District administration. Prior to debris collection, a fine spray of water shall be sprinkled with pressurized fine spray to contain/limit dust levels at source. Following are the locations identified for disposal debris during excavation or demolition process (ref. Figure 2-5 under Section 2 of ESIA volume). <table border="1" data-bbox="519 1152 1482 1291"> <thead> <tr> <th>S. No.</th> <th>Location</th> <th>Type of Land</th> <th>Holding Capacity (m³) and Dimensions</th> </tr> </thead> <tbody> <tr> <td>1</td> <td>7+900 (LHS)</td> <td>Govt/ PWD Land</td> <td>4,000m³ (L=100m W=8m; H=5m)</td> </tr> <tr> <td>2</td> <td>8+900 (LHS)</td> <td>Govt/ PWD Land</td> <td>3,600m³ (L=80m; W=9m; H=5m)</td> </tr> </tbody> </table>	S. No.	Location	Type of Land	Holding Capacity (m ³) and Dimensions	1	7+900 (LHS)	Govt/ PWD Land	4,000m ³ (L=100m W=8m; H=5m)	2	8+900 (LHS)	Govt/ PWD Land	3,600m ³ (L=80m; W=9m; H=5m)		
S. No.	Location	Type of Land	Holding Capacity (m ³) and Dimensions													
1	7+900 (LHS)	Govt/ PWD Land	4,000m ³ (L=100m W=8m; H=5m)													
2	8+900 (LHS)	Govt/ PWD Land	3,600m ³ (L=80m; W=9m; H=5m)													

S. No	Project Stage/Activity	Mitigation Management Measures/GIIP Measures				Responsibility	
						Planning and Execution	Supervision/ Monitoring
		3	10+200 (LHS)	Govt/ PWD Land	12,000m ³ (L=150mW=8m; H=10m)		
		4	11+000 (LHS)	Govt/ PWD Land	20,000 m ³ (L=200mW=10m; H=10m)		
		5	12+350 (LHS)	Govt/ PWD Land	6,300m ³ (L=70mW=15m; H=6m)		
			12+430 (LHS)		2,500 m ³ (L=50m; W=10m; H=5m)		
		6	13+800 (LHS)	Govt/ PWD Land	2,400 m ³ (L=40mW=10m; H=6m)		
			13+900 (LHS)		4,800m ³ (L=120mW=8m; H=5m)		
			14+000 (LHS)		1,600m ³ (L=40mW=8m; H=5m)		
		7	17+850 (LHS)	Govt/ PWD Land	50,000m ³ (L=80m; W=10m; H=6m)		
		8	20+100 (LHS)	Govt/ PWD Land	50,000m ³ (L=100mW=25m; H=6m)		
		9	25+500 (LHS)	Govt/PWD Land	2,000 m ³ (L=40m; W=10m; H=5m)		
		10	25+650 (LHS)	Govt/ PWD Land	2,000 m ³ (L=50m; W=10m; H=4m)		
		11	27+250 (LHS)	Govt/ PWD Land	4,000 m ³ (L=100m; W=10m; H=4m)		
		12	27+450 (LHS)	Govt/ PWD Land	2,560m ³ (L=80m; W=8m; H=4m)		
			27+550 (LHS)		2,800m ³ (L=100m; W=7m; H=4m)		
		13	27+700 (LHS)	Govt/ PWD Land	2,100m ³ (L=70mW=5m; H=6m)		
		Total holding Capacity of Muck/ Debris			1,72,600 m³		
		<ul style="list-style-type: none"> • Prior to disposal, the excavated material shall screen for recovery of good soil, which can be used in the construction of sub grade, shoulders, back filling of retaining/breast/toe walls and rock boulders for gabions and or any other road construction works. The use of recovered material in the project is subject to conforming to technical specification and standards prescribed for the project and approval by the CSC. • The noise levels during excavation shall be reduced/limited through deployment of well-maintained construction vehicles/equipment/machinery. All excavation activities shall be undertaken during daytime and at normal work pace, particularly in settlement areas. 					

S. No	Project Stage/Activity	Mitigation Management Measures/GIIP Measures	Responsibility	
			Planning and Execution	Supervision/ Monitoring
22	Accessibility	<ul style="list-style-type: none"> The Contractor shall provide safe and convenient passage for vehicles, pedestrians and livestock to and from roadside and property access connecting the project road, providing temporary diversions, wherever required. The Contractor shall also ensure that the existing access roads shall not be disrupted without providing alternate and adequate temporary diversion provisions. After completion of the work disrupted/damaged access roads shall be restored by the Contractor. 	Contractor	<u>Supervision:</u> Environment & Social Specialists of CSC <u>Monitoring:</u> Environmental Specialist of HPRIDCL under the overall guidance of Project Director
23	Planning for Traffic Diversions and Detours	<ul style="list-style-type: none"> Traffic Control Plans shall be prepared by the Contractor and submitted to CSC for approval seven days prior to commencement of works on any section of road. Temporary diversions shall be constructed with the approval of the CSC and local/ district admin authorities as required(ref. Appendix-6). The traffic control plans shall include details of temporary diversions, traffic safety arrangements for construction under traffic, details of traffic arrangement after cessation of work each day, safety measures for night-time traffic and precaution for transportation of hazardous materials, among others. The Contractor shall ensure that the diversion/detour is always maintained in good and easily usable condition, particularly during the monsoon to avoid disruption to traffic flow. The Contractor shall also inform all stakeholders/local community of changes to traffic routes, conditions and pedestrian access arrangements under intimation to CSC. The temporary traffic detours shall be kept free of dust by sprinkling of water as required under specific conditions (depending on weather conditions, construction in the settlement areas and volume of traffic. Normally 3-4 times of water sprinkling per day shall suffice). In addition, a road safety awareness campaign including securitization about traffic noise levels shall be conducted by CSC at all the schools located along the project road. Such campaign shall be conducted first prior to commencement of road construction works at such specific stretches and/or after the installation of proposed noise barriers, as warranted. 	Contractor	<u>Supervision:</u> Environment & Social Specialists of CSC <u>Monitoring:</u> Environmental Specialist of HPRIDCL under the overall guidance of Project Director
PROCUREMENT OF CONSTRUCTION MATERIAL				
24	Earth from Borrow Areas for	<ul style="list-style-type: none"> The location, shape and size of the designated borrow areas shall be as approved by the CSC and operated in accordance to the IRC recommended practice for borrow pits for road 	Contractor	<u>Supervision:</u> Environment & Social

S. No	Project Stage/Activity	Mitigation Management Measures/GIIP Measures	Responsibility	
			Planning and Execution	Supervision/ Monitoring
	Construction	<p>embankments (IRC 10: 1961). The borrowing operations shall be carried out as specified in the guidelines of project road specific ESMP (refer Appendix-1 of ESMP document) for siting and operation of borrow areas.</p> <ul style="list-style-type: none"> • If unpaved surfaces used for the haulage of borrow materials, passing through the settlement areas or habitations, the same shall be maintained dust free by the Contractor. Sprinkling of water shall be carried out twice a day to control dust along such roads during their period of use. And clearing of the spillages, on a daily basis • During dry seasons (winter and summer) frequency of water sprinkling shall be increased in the settlement areas and CSC shall decide frequency of sprinkling depending on the local requirements. • Contractor shall rehabilitate the borrow areas as soon as borrowing operations are completed from a specific area is over in accordance with the approved borrow area management and redevelopment Plan. 		<p>Specialists of CSC</p> <p><u>Monitoring:</u> Environmental Specialist of HPRIDCL under the overall guidance of Project Director</p>
25	Quarry Operations Crushers	<ul style="list-style-type: none"> • The Contractor shall source materials from quarries only after consent of the competent authorities like Department of Mining and District Administration. In view of the special situation of excavation of the hillside, Contractor shall get an opportunity to reuse the same excavated material for road construction. • The Contractor shall have a Comprehensive Quarry Redevelopment plan, as per the HP Mineral Policy 2013/guidelines and submit a copy to CSC prior to opening of the quarry site. The quarry operations shall be undertaken within the rules and regulations in force. • The establishment of crusher plant shall be done as per the existing guidelines (HP Mineral Policy 2013) for setting up of stone crushing units in Himachal Pradesh. 	Contractor	<p><u>Supervision:</u> Environment & Social Specialists of CSC</p> <p><u>Monitoring:</u> Environmental Specialist of HPRIDCL under the overall guidance of Project Director</p>
26	Transporting Construction Materials and Haul Road Management	<ul style="list-style-type: none"> • Contractor shall maintain all roads (existing or built for the project), which are used to be for transporting construction materials, equipment and machinery. All vehicles delivering fine materials to the site shall be covered with tarpaulin to avoid spillage of materials. • All roads used by vehicles of the Contractor or any of his sub-contractor or suppliers of materials and similarly roads, which are part of the project construction works, shall be kept clear of all dust/mud/spillage or extraneous materials dropped by such vehicles. • Contractor shall arrange for regular water sprinkling as necessary for dust suppression of all such roads and surfaces. If a community/village road is to be used as a haulage road then drivers and other involved workers shall be sensitized about How to deal with community and 	Contractor	<p><u>Supervision:</u> Environment & Social Specialists of CSC</p> <p><u>Monitoring:</u> Environmental Specialist of HPRIDCL under the overall guidance of Project</p>

S. No	Project Stage/Activity	Mitigation Management Measures/GIIP Measures	Responsibility	
			Planning and Execution	Supervision/ Monitoring
		<p>avoid conflictsö.</p> <ul style="list-style-type: none"> Community shall be consulted by Contractor to fix the timings of road usage and should avoid peak hours, if any to avoid/minimize inconvenience to local community. 		Director
27	Water requirement of project and sanitation facilities	<ul style="list-style-type: none"> The contractor shall not over depend on any one single source and shall identify multiple sources (at least more than one), to avoid conflict of interest between pre-existing users of water sources and the contractor. Water requirements of project are to be met from only existing tube/dug wells, with prior approval of CSC and competent authorities. Contractor shall preferably have more than one source to avoid over dependence on single source and affect pre-existing users. Contractor shall obtain prior approvals from ground water department and/ or other designated department like IPH department where required and submit a copy of the same to CSC. Project region/area and entire Mandi district is not categorized as over exploited area and therefore contractor can even construct new tube wells specially for the water requirements of the project, if required, with requisite prior permissions/ approvals from competent authorities as required/ applicable. Water for construction should not be sourced from any waterbody/source used by community for drinking purpose, but can be taken from waterbodies, which are neither used for drinking water or domestic purposes. However, before abstracting the water the contractor has to obtain written permission from the panchayat and/or from the Irrigation and Public Health Department in such cases. The Contractor shall consider development of new surface water bodies at suitable places in the vicinity of the project road and or renovation of existing surface water bodies with prior permission of the village panchayat for harvesting of water during rainy season. This water can be used for construction purpose and on completion of the construction the same can be handed over to the community for maintenance and use. Contractor should preferably explore/identify local depressions along the alignment in consultation with the local panchayat to be developed as water storage areas. The CMU can enter into an agreement with the panchayat for development of this water body and using the water stored on it for construction purpose. The Contractor should identify suitable water sources for meeting the construction water demand including the construction of dedicated tube wells and take prior permissions for sourcing of water from competent authorities like IPH and other designated departments. Overall, as there are no major perennial surface water bodies along and/or in the vicinity of the 	Contractor	<p><u>Supervision:</u> Environment & Social Specialists of CSC</p> <p><u>Monitoring:</u> Environmental Specialist of HPRIDCL under the overall guidance of Project Director</p>

S. No	Project Stage/Activity	Mitigation Management Measures/GIIP Measures	Responsibility	
			Planning and Execution	Supervision/ Monitoring
		<p>project road, the project road construction cannot completely depend on surface water bodies and may have to largely depend on ground water sources.</p> <ul style="list-style-type: none"> • Construction water not be sourced from any tube wells, without prior permission of the owners or the authorities or local bodies. The permission from state ground water department and/or designated department shall be obtained in case new tube wells are to be constructed; • Contractor shall adopt use of plasticizers/super plasticizers in concrete production to reduce water consumption. The road construction authority by itself does not involve any operations, which lead to generation of effluents/emissions that may directly or indirectly impact either surface and/or ground water resources. 		
28	Vulnerability aspects at all Construction and Operation sites	<ul style="list-style-type: none"> • The overall vulnerability of Mandi district including the project road is categorized as High. In order to ensure safety of work force during any kind of natural calamity (vulnerable situation) like earthquake, landslide, flood, wind, an ERP (emergency response plan) must be prepared by contractor, which shall be duly approved by CSC. District authorities shall be consulted for their coordination, in cases of occurrence emergency/natural calamities • All work force irrespective of levels, are to be provided with training to respond in an emergency and periodic mock drill shall be conducted to ensure the preparedness to respond any emergency situations. 	Contractor	<p><u>Supervision:</u> Environment & Social Specialists of CSC</p> <p><u>Monitoring:</u> Environmental Specialist of HPRIDCL under the overall guidance of Project Director</p>
29	Occupational Safety, Health, First Aid Facilities and Documenting Safety at all Construction and Operation sites	<ul style="list-style-type: none"> • All labour shall be provided with safety instructions daily, depending upon the work, for which they are likely to be deployed for the day/shift. Labour shall be provided with PPEs at no cost and ensure that same is always being used by work force, while at work. In case of the damaged or lost PPEs, same shall be replaced without any cost to labour. • All labour shall be instructed and encouraged to report, irrespective of small or major or fatal injury to the supervisory staff and all such incidents shall be documented, and ensure such incidents are not repeated by taking adequate precautions. All Supervisory staff shall be provided with mobile phones for better communication across all operational areas, in case of emergency or otherwise • The contractor shall make available a standby vehicle for emergency purpose for transportation in case of accident with serious injuries at site. Any accident with fatalities shall be reported promptly to CSC and shall take measures to compensate the affected person in accordance with existing regulation. • First aid facilities and free emergency care shall be provided to all workforce, irrespective of 	Contractor	<p><u>Supervision:</u> Environment & Social Specialists of CSC</p> <p><u>Monitoring:</u> Environmental Specialist of HPRIDCL under the overall guidance of Project Director</p>

S. No	Project Stage/Activity	Mitigation Management Measures/GIIP Measures	Responsibility	
			Planning and Execution	Supervision/ Monitoring
		<p>their rank/level and no cost shall be recovered from them on this account.</p> <ul style="list-style-type: none"> The contractor shall deploy a medical practitioner periodically at camp site to attend to health issues/first aids and shall conduct regular health check-up of all staffs and workers employed in project. Further, no wages shall be cut for period of absence as a result of injury ó The contractor shall mandatorily have Contractor All Risk (CAR) policy to cover workers of main contractor and as well as all sub-contractors and third party. All work site(s) shall have first aid kits and details of major/nearby hospitals displayed prominently in local language, in case of emergency and/fatalities to work force and/or public, as a consequence of operations. The supervisory staff shall be provided with wireless communication system (mobile telephones for better communication at operational area and also with other operational area, in case of emergency or otherwise. 		
CONSTRUCTION WORK				
30	Floods, drainage including storm water management at Operational areas	<ul style="list-style-type: none"> Provision of enough cross-drainage structures with adequate capacities shall reduce both the chances as well as impacts of floods. In case of seasonal streams along project road, ensure construction of RCC aprons on the upstream side of seasonal streams and channelized the water on the downstream side with protection measures to control erosion of soil, which in turn reduce floods on downstream areas. Project design include provision for construction of RCC/ stone boulder aprons on the upstream side along with steps with guiding walls and RCC/ stone boulder aprons on downstream side to channelize the water and dissipate energy to control the erosion and subsequently reduce floods on downstream areas. The engineering design drawings for CD structures at all locations along project road has included such required protection measures. The Contractor shall ensure that no construction materials like earth, stone, or are disposed off in a manner that can restrict/block the flow of drainage in and around the operational areas. Ensure that no site clearance soil/debris are dumped into the waterways prior to commencement of road construction operations and the waterways is to be periodically checked and cleaned throughout the construction phase for deposition of construction debris during construction phase and follow it up with final clean up just prior to opening of the road for traffic and handing over of road. Also, it needs to be ensured that no water logging occurs along road construction operational area during rainy days/ season and in turn affect the existing road users. In case of excess water 	Contractor	<p><u>Supervision:</u> Environment & Social Specialists of CSC</p> <p><u>Monitoring:</u> Environmental Specialist of HPRIDCL under the overall guidance of Project Director</p>

S. No	Project Stage/Activity	Mitigation Management Measures/GIIP Measures	Responsibility	
			Planning and Execution	Supervision/ Monitoring
		logging, the same shall be emptied using dewatering pump or any other means as may be required, to ensure existing road users are not unduly affected. The contractor while providing outfall of cross drainage structure shall avoid discharging to private land or agriculture land.		
POLLUTION PREVENTION				
31	Water Pollution	<ul style="list-style-type: none"> • The Contractor shall provide oil interceptor and take pre-cautionary measures to ensure that no water pollution occurs through surface runoff from construction vehicle parking areas, fuel/lubricants storage sites, vehicle, and machinery/equipment maintenance sites. • Contractor shall ensure that all vehicle/machinery and equipment maintenance and refueling shall be carried out in such a manner that spillage of fuel and lubricants do not contaminate soil and groundwater. • All other off-site operational areas like camp site, work force camp sites, which are likely to have potential for pollution, are to be provided with on-site mobile sanitary facilities, the effluents/waste discharges of which shall be transported to nearest sewage treatment plants through mobile tankers. • The oil/lube storage shall be under roofed areas with impermeable cement concrete surfaces. Thus, the project operations shall not have any significant scope for soil or surface and/or ground water contamination. Thus, road construction project shall not impact ground water sources. • The water usage pattern within the construction camps can be minimized by adopting following best practices: <ul style="list-style-type: none"> ○ Use buckets for washing purposes instead of using running water. ○ Use of auto shut off taps (without sensors) in labour accommodation. ○ Install water meters with main supply pipes/water tanks/bore well to assess quantity of consumed water. ○ Create awareness among the camp site, work force camp sites at all levels. • Areas used for handling of fuel and lubricants, wherever applicable shall be impermeable surfaces and under roof to prevent groundwater and soil contamination in the event of accidental spills. • All other off-site operational areas like camp site, work force camp sites, which are likely to have potential for pollution, are to be provided with on-site mobile sanitary facilities, the effluents/waste discharges of which shall be transported to nearest sewage treatment plants 	Contractor	<p><u>Supervision:</u> Environment & Social Specialists of CSC</p> <p><u>Monitoring:</u> Environmental Specialist of HPRIDCL under the overall guidance of Project Director</p>

S. No	Project Stage/Activity	Mitigation Management Measures/GIIP Measures	Responsibility																																																					
			Planning and Execution	Supervision/ Monitoring																																																				
		<p>through mobile tankers.</p> <ul style="list-style-type: none"> The camp site and work force camp sites shall be provided with septic tank with soak pit arrangement of adequate capacity and numbers as required. All toilets and wash areas within the camp site and work force camps shall be provided with septic tanks and soak pit arrangements of adequate capacity. No wastewater from the camp/work force site shall be discharged directly into any surface water channels or drain, without any treatment, which eventually join surface water bodies. Typically, each 5m Length, 2m Breadth and 1.5 m Clear depth with 0.3 free board with soak pit arrangement, which can serve up to 50 users at peak level as per CPWD specifications. CPHEEO, Ministry of Housing and Urban Affairs, GoI recommended sizes of septic tank (as per BIS 2470 part I) up to 300 users are given in the following table. The number of septic tanks required at the workforce camps and camp sites can developed demanding up to the number of locations and users. BIS 2470 part I may be referred for construction details of septic tanks and soak pit disposal arrangement(ref. Appendix-14). <p style="text-align: center;">CPHEEO Recommended size of septic tank up to 300 users</p> <table border="1" style="margin-left: auto; margin-right: auto;"> <thead> <tr> <th rowspan="2">No. of Users</th> <th rowspan="2">Length (m)</th> <th rowspan="2">Breadth (m)</th> <th colspan="2">Liquid depth (m) (cleaning interval of)</th> </tr> <tr> <th>2 years</th> <th>3 years</th> </tr> </thead> <tbody> <tr> <td>5</td> <td>1.5</td> <td>0.75</td> <td>1.0</td> <td>1.05</td> </tr> <tr> <td>10</td> <td>2.0</td> <td>0.90</td> <td>1.0</td> <td>1.40</td> </tr> <tr> <td>15</td> <td>2.0</td> <td>0.90</td> <td>1.3</td> <td>2.00</td> </tr> <tr> <td>20</td> <td>2.3</td> <td>1.10</td> <td>1.3</td> <td>1.80</td> </tr> <tr> <td>50</td> <td>5.0</td> <td>2.00</td> <td>1.0</td> <td>1.24</td> </tr> <tr> <td>100</td> <td>7.5</td> <td>2.65</td> <td>1.0</td> <td>1.24</td> </tr> <tr> <td>150</td> <td>10.0</td> <td>3.00</td> <td>1.0</td> <td>1.24</td> </tr> <tr> <td>200</td> <td>12.0</td> <td>3.30</td> <td>1.0</td> <td>1.24</td> </tr> <tr> <td>300</td> <td>15.0</td> <td>4.00</td> <td>1.0</td> <td>1.24</td> </tr> </tbody> </table> <p>Notes:</p> <ul style="list-style-type: none"> Capacities are recommended on the assumption that discharges from only WC shall be treated in the septic tank. 	No. of Users	Length (m)	Breadth (m)	Liquid depth (m) (cleaning interval of)		2 years	3 years	5	1.5	0.75	1.0	1.05	10	2.0	0.90	1.0	1.40	15	2.0	0.90	1.3	2.00	20	2.3	1.10	1.3	1.80	50	5.0	2.00	1.0	1.24	100	7.5	2.65	1.0	1.24	150	10.0	3.00	1.0	1.24	200	12.0	3.30	1.0	1.24	300	15.0	4.00	1.0	1.24		
No. of Users	Length (m)	Breadth (m)				Liquid depth (m) (cleaning interval of)																																																		
			2 years	3 years																																																				
5	1.5	0.75	1.0	1.05																																																				
10	2.0	0.90	1.0	1.40																																																				
15	2.0	0.90	1.3	2.00																																																				
20	2.3	1.10	1.3	1.80																																																				
50	5.0	2.00	1.0	1.24																																																				
100	7.5	2.65	1.0	1.24																																																				
150	10.0	3.00	1.0	1.24																																																				
200	12.0	3.30	1.0	1.24																																																				
300	15.0	4.00	1.0	1.24																																																				

S. No	Project Stage/Activity	Mitigation Management Measures/GIIP Measures	Responsibility	
			Planning and Execution	Supervision/ Monitoring
		<ul style="list-style-type: none"> ▪ Provision of 300mm should be made for free broad. ▪ Sizes of septic tank are based on certain assumption on peak discharges, as estimated in IS:2470 (part 1) and while choosing the size of septic tank exact calculations shall be made. ▪ For users over 100, the tank may be divided into independent parallel chambers of maintenance and cleaning. 		
32	Air Pollution	<ul style="list-style-type: none"> • The Contractor shall take every precaution to reduce the level of dust from contractor's establishment sites and/or operational construction sites involving earthwork by sprinkling of water and suppression of dust(ref. Appendix-8 for relevant standards). • All tipper trucks, carrying construction debris shall be covered with net cloth and wetted prior to dispatch of every trip, to prevent en-route spills as well as airborne dust during transit. Tipper trucks shall not be overloaded beyond designated capacities and shall be provided with tail board, to avoid en-route spills. • The dust levels during collection and loading operations of construction debris shall be controlled through periodical sprinkling of water through mobile water tankers of adequate capacity fitted with pressurized fine spray with hose reels and stationed at excavation areas. • The Contractor shall procure the construction plants and machinery, which shall conform to the pollution control norms specified by the MoEF&CC/CPCB/HPSPCB. 	Contractor	<p><u>Supervision:</u> Environment & Social Specialists of CSC</p> <p><u>Monitoring:</u> Environmental Specialist of HPRIDCL under the overall guidance of Project Director</p>
33	Emission from Construction Vehicles, Equipment and Machineries	<ul style="list-style-type: none"> • Contractor shall ensure that all vehicles, equipment and machinery used for construction are regularly maintained and confirm that pollution emission levels comply with the relevant requirements of CPCB and/ Motor Vehicles Rules. • The Contractor shall submit PUC certificates for all vehicles/ equipment/ machinery used for the Project. • Environmental monitoring of all construction operational sites and contractor's establishment sites shall be conducted in frequency mentioned in Environmental Monitoring Plan of ESMP and agreed/ approved C-ESMP. 	Contractor	<p><u>Supervision:</u> Environment & Social Specialists of CSC</p> <p><u>Monitoring:</u> Environmental Specialist of HPRIDCL under the overall guidance of Project Director</p>
34	Noise Pollution: Noise from Vehicles, Plants and Equipment Construction of Noise barriers at	<p>The Contractor shall confirm to the following:</p> <ul style="list-style-type: none"> • All Construction plants and equipment used in construction shall strictly conform to the MoEF&CC/CPCB/HPSPCB requirements with respect to emissions and noise levels/standards. • Servicing/routine maintenance of vehicles, equipment and machinery shall be regular and up to the satisfaction of the CSC to keep emissions and noise levels as per norms/minimum. • At the construction sites within 150 m of the nearest habitation, noisy construction works such 	Contractor	<p><u>Supervision:</u> Environment & Social Specialists of CSC</p> <p><u>Monitoring:</u> Environmental Specialist of HPRIDCL under the</p>

S. No	Project Stage/Activity	Mitigation Management Measures/GIIP Measures	Responsibility													
			Planning and Execution	Supervision/ Monitoring												
	selected sensitive Receptors (Schools and Hospitals)	<p>as crushing, operation of DG sets, use of high noise generation equipment shall be stopped during the night-time between 10.00 pm to 6.00 am.</p> <ul style="list-style-type: none"> In order to limit noise levels at some of the sensitive receptors along project road, provision for noise barriers is made at 2 locations as hereunder: <table border="1"> <thead> <tr> <th>S. No</th> <th>Chainage (Km)</th> <th>Sensitive Receptors</th> <th>Mitigation Measure</th> </tr> </thead> <tbody> <tr> <td>1</td> <td>4+770</td> <td>SaraswatiVidyaMandir Middle School</td> <td>Barrier for noise attenuation</td> </tr> <tr> <td>2</td> <td>22+230</td> <td>Unity Public School</td> <td>Barrier for noise attenuation</td> </tr> </tbody> </table> <ul style="list-style-type: none"> All the noise barriers shall be provided with polycarbonate sheets with 90% light transmittance fitted with polypropylene rubber gaskets and mounted on steel frames shall installed along school building, without affecting the aesthetics. Noise barriers are proposed for two schools shall be constructed in advance (prior to commencement of road construction works) at each sensitive receptor like schools, which have been identified for providing the noise control measures (Refer Section 3 for design/drawings and general arrangement of noise barrier as well as crash barriers). In addition, a road safety awareness campaign including sensitization about traffic noise levels shall be conducted by CSC at all the schools located along the project road. Such campaign shall be conducted first prior to commencement of road construction works at such specific stretches and/or after the installation of proposed noise barriers, as warranted. Ensure no conflicting situation develop/arise with the stakeholders along project road and local community including School authorities during the entire road construction phase through a responsive communication channels and resolve any grievances through a responsive GRM and conflict management initiatives. 	S. No	Chainage (Km)	Sensitive Receptors	Mitigation Measure	1	4+770	SaraswatiVidyaMandir Middle School	Barrier for noise attenuation	2	22+230	Unity Public School	Barrier for noise attenuation		overall guidance of Project Director
S. No	Chainage (Km)	Sensitive Receptors	Mitigation Measure													
1	4+770	SaraswatiVidyaMandir Middle School	Barrier for noise attenuation													
2	22+230	Unity Public School	Barrier for noise attenuation													
35	Waste Management	<ul style="list-style-type: none"> The Contractor's ESMP (C-ESMP) shall include a Waste Management Plan for Hazardous and Non-Hazardous waste prepared in accordance with requirements stipulated in (a) The Batteries (Management & Handling) Rules, 2001 (b) Municipal Solid Wastes (Management and Handling) Rules, 2000, (c) Hazardous Waste (Management, Handling & Transboundary Movement) Rules, 2016 and (d) Construction and Demolition Waste Management Rules, 2016. The waste management plan shall be submitted for approval of CSC(ref. Appendix-12). The camp site shall have compost pits for treating organic waste and separate bins for 	Contractor	<p><u>Supervision:</u> Environment & Social Specialists of CSC</p> <p><u>Monitoring:</u></p>												

S. No	Project Stage/Activity	Mitigation Management Measures/GIIP Measures	Responsibility	
			Planning and Execution	Supervision/ Monitoring
		<p>collecting the inorganic waste, which shall be disposed at nearest municipal disposal sites. The nearest such sites are available at Mandi.</p> <ul style="list-style-type: none"> The contractor shall collect and store hazardous waste generated at camp sites in HDPE/steel drums and stored in a segregated roofed area and periodically disposed at approved waste disposal facilities by HPSPCB. The nearest such facility is located at BaddiBarotiwalaNalagarh Industrial Area (BBN) in the adjoining Solan District. The contractor shall also identify HPSPCB authorized recycling agency for handling used oil. The used lubes/oil and discarded batteries shall be disposed only through recyclers authorized by HPSPCB. 		Environmental Specialist of HPRIDCL under the overall guidance of Project Director
SAFETY				
36	Occupational Health and Safety of Labours/ Work force	<ul style="list-style-type: none"> The Contractor shall comply with all the precautions as required for ensuring the safety of the workmen as per the GoHP and Government of India norms/regulations All workforce deployed shall be governed by labour management procedures of HPRIDCL and Himachal Building and Other Construction Workers (Regulation of Employment and Conditions of Service) Act, with regards to safety and welfare measures (including equal wages for men and women) for workers employed at building and other construction sites. The Contractor shall make sure that during the construction work all relevant provisions of Building and other Construction Workers (regulation of Employment and Conditions of Services) Act, are adhered to. The Contractor shall not employ any person below the age of 18 years for any construction work and no woman shall be employed for hazardous work, unless and otherwise she is trained to carry put such work. The Contractor shall also ensure that no paint containing lead or lead products is used except in the form of paste or readymade paint. And no woman workers are involved in such work The Contractor shall mark -hard hatø and -no smokingø and other -high riskø areas and enforce compliance to use of PPE with zero tolerance. These shall be reflected in the Construction Safety Plan to be prepared by the Contractor during mobilization and shall be approved by CSC The contractor shall provide to all work force deployed at work sites protective footwear, protective goggles and face masks to the workers employed in asphalt works, concrete works, crusher etc. The contractor shall provide welderø protective eye-shields to workers who are engaged in welding works, Earplugs to workers exposed to loud noise, and workers working in crushing or 	Contractor	<p><u>Supervision:</u> Environment & Social Specialists of CSC</p> <p><u>Monitoring:</u> Environmental Specialist of HPRIDCL under the overall guidance of Project Director</p>

S. No	Project Stage/Activity	Mitigation Management Measures/GIIP Measures	Responsibility	
			Planning and Execution	Supervision/ Monitoring
		<p>compaction.</p> <ul style="list-style-type: none"> It shall be made mandatory to wear PPEs at work site. The PPEs shall be provided at no cost to workforce and shall be replaced once in three months. Any damaged/lost PPEs shall be replaced with no cost to workforce. To promote and encourage a Safety culture, senior most engineers in Contractors and consultantsøteams shall wear helmets and safety jackets at all operational sites. Visitors/officials to work sites are to be provided with PPEs (hard hats and safety shoes) and shall be briefed ongoing operations on that specific time and related safety requirement at work site including safe distances to keep during the site visit. Work force shall be subjected only to standard work shifts/hours. Overtime allowances, if applicable/warranted shall be paid with ceiling limits. Working beyond such ceiling limits shall be discouraged, even if, so desired workforce or contractor. 		
37	Traffic and Safety	<ul style="list-style-type: none"> Ensure, traffic diversions are in place, to minimize the inconvenience to the existing road users during the road construction phase. Wherever required, adequate number of uniformed traffic wardens with reflective batons shall the deployed to manage the traffic for the entire construction phase. Road construction schedule near sensitive receptors like schools and hospitals shall be informed to the concerned authorities well in advance. All works near sensitive receptors shall be well planned and works shall be completed in shortest possible time, with minimal inconvenience to users of sensitive receptors locations. If warranted, steel barricades shall be used to minimize the inconvenience to the road users as well as occupants of the sensitive receptors. Adequate traffic diversions near sensitive receptors shall be planned with adequate number of uniformed traffic wardens with reflective batons shall the deployed to manage the traffic, to ensure safety and minimal inconvenience to users of sensitive receptors location. Noise mitigation measures such as construction of noise barriers etc. shall be constructed for the identified sensitive receptors, well in advance of commencement of road construction works. Dust suppression measures like regular sprinkling of water shall be carried out with more precaution near sensitive receptors to ensure dust levels kept to minimum. The construction debris and spills cleared of all construction debris daily near sensitive receptors. While undertaking, road construction works near the natural water bodies and/or water sources 	Contractor	<p><u>Supervision:</u> Environment & Social Specialists of CSC</p> <p><u>Monitoring:</u> Environmental Specialist of HPRIDCL under the overall guidance of Project Director</p>

S. No	Project Stage/Activity	Mitigation Management Measures/GIIP Measures	Responsibility	
			Planning and Execution	Supervision/ Monitoring
		<p>along the project road, steel barricades shall be used to completely avoid trespassing of the construction labour and to avoid/prevent spills of the construction waste (solid or liquid) into the water body.</p> <ul style="list-style-type: none"> • Extreme care shall be taken to ensure that no damage occurs to such natural water bodies and/or water sources along the project road due to the road construction works. All work forces shall be specifically oriented to strictly follow these instructions. 		
38	Information Signage and Hoardings	<ul style="list-style-type: none"> • The Contractor shall provide, erect and maintain informatory /safety signs, hoardings written in English and local language (Hindi), wherever required or suggested by CSC. 	Contractor	<p><u>Supervision:</u> Environment & Social Specialists of CSC</p> <p><u>Monitoring:</u> Environmental Specialist of HPRIDCL under the overall guidance of Project Director</p>
39	Risk from Electrical Equipment(s)	<p>The Contractor shall take all required precautions to prevent danger from electrical equipment and ensure that -</p> <ul style="list-style-type: none"> • No material shall be so stacked or placed as to cause danger or inconvenience to any person or the public. • All necessary fencing and lights shall be provided to protect the public in construction zones. • All machines to be used in the construction shall conform to the relevant Indian Standards (IS) codes, shall be free from patent defect, shall be kept in good working order, shall be regularly inspected and properly maintained as per IS provision and to the satisfaction of CSC. 	Contractor	<p><u>Supervision:</u> Environment & Social Specialists of CSC</p> <p><u>Monitoring:</u> Environmental Specialist of HPRIDCL under the overall guidance of Project Director</p>
40	Construction activity near water bodies and/or bridge construction sites along Project Road	<ul style="list-style-type: none"> • Schedule all construction activities at/along waterfront areas to dry or non-monsoon seasons, particularly excavation works and casting of concrete structures/works • Identify, minimize, and demarcate the areas earmarked for construction activities with barricades • Cordon-off and regulate the entry and exit points for workforce /construction labour for work sites. No workforce shall enter the waterfront area unless it is warranted for construction works and same shall have prior authorized permission 	Contractor	<p><u>Supervision:</u> Environment & Social Specialists of CSC</p> <p><u>Monitoring:</u> Environmental Specialist</p>

S. No	Project Stage/Activity	Mitigation Management Measures/GIIP Measures	Responsibility	
			Planning and Execution	Supervision/ Monitoring
		<ul style="list-style-type: none"> No construction related establishments like concrete batching plants, labour/workforce camps/material stack yards parking and vehicle servicing areas shall be established within 500 meters of the waterfront areas All construction related establishments shall have adequate drainage facilities and potential contaminant areas shall have covered roofs and/or provided with segregated drainage systems, which shall have pre-treatment units like oil/grease separator, settling tanks, prior to its discharge. No untreated waste shall be disposed-off into any natural water streams /channels under any circumstances All construction and operational areas shall be scavenged for clearing of any material spills daily, prior to monsoon and after the completion of work. All construction sites near waterfront shall be maintained in a clean and tidy at all times during construction phase and completely cleared off from waterfront area, prior to monsoon. All hazardous waste materials from operational and vehicle servicing areas shall be collected, stored under roof areas and safely disposed-off as per state pollution control broad norms All the workforce at construction related establishment sites shall be provided with adequate water, sanitation facilities. The worksites, specifically near the waterfront shall have provision for mobile toilets of at least one mobile toilet of 2-seater capacity (1 men and 1 woman with separate entrances) is stationed at a suitable place, within 100 meters from each operational area. The mobile toilet shall have at least 1000 liters overhead water storage, well always maintained and in usable condition. Bottom tanks of mobile toilets shall be regularly cleaned, and overhead tank replenished as per requirement. Work force shall be oriented to use mobile toilets and avoid using nearby open places/waterfront. Every operational area shall be provided with one mobile drinking water kiosk having a storage of 300 liters and placed at a suitable place within 100 meters from work site All workforce deployed near waterfront shall be adequately oriented during induction and thereafter at daily briefing/toolbox talks about safety procedures and requirements particularly when working near waterbodies/waterfronts and provided with appropriate safety gear including retro-reflective jackets at worksite Worksites near the waterfront shall have provision for lifesaving jackets and ropes (at least 2 sets each) placed at an easily accessible location(s) near waterfront for rescue operations, in 		of HPRIDCL under the overall guidance of Project Director

S. No	Project Stage/Activity	Mitigation Management Measures/GIIP Measures	Responsibility	
			Planning and Execution	Supervision/ Monitoring
		<p>case of any accidental falls of workforce into water. The same shall be extended and maintained even for the operation phase of the passenger berths.</p> <ul style="list-style-type: none"> • Ensure no waste of any form is dumped or construction material or waste/debris spills into water body during the entire construction works near waterfront. All such waste materials/spills during construction shall be immediately cleared off to ensure no impacts on water quality. • The channel bed on the upstream and downstream sides of the water body up to 500m shall be cleaned up for any construction debris/ waste spills etc. prior to onset of monsoon and before demobilization of construction works/ activities from such sites. • The Contractor shall clear all temporary structures; dispose all garbage, night soils and POL (Petroleum, Oil and Lubricants) wastes as per Comprehensive Waste Management Plan and as approved by CSC. 		
MITIGATION MEASURES SPECIFIC TO <u>ASSOCIATED FACILITIES</u>				
41	Mitigation measures specific to <u>Associated Facilities</u>	<ul style="list-style-type: none"> • HPRIDCL has no direct control over the construction contracts of 4 bridges, which are awarded by HPPWD through funding from the Central Road Fund (CRF) of Govt. of India and presently at the different stages of completion (50-60%). Consultations with the concerned PWD division responsible for these bridges have informed that the respective contract clauses of these bridges do not include any specific environmental mitigation measures other than those which are generally deemed to be covered as incidental to civil works. Photographs of the bridge construction sites are given in Figure 7-1 & 7-2 of Section 7 of ESIA volume, which clearly warrant mitigation measures to minimize/ avoid impacts due to bridge construction at respective sites. • Since, these bridges, being integral to the project road and are considered to be the Associated Facilities, the following mitigation measures shall be undertaken by the contractor and implemented under the supervision of CSC. <ul style="list-style-type: none"> ○ Ensure no concrete batching plants, camp sites, material stack sites, vehicle servicing areas for the project road construction works will be established along river/ stream beds at these locations of Associated Facilities. ○ Undertake cleaning the river/ stream bed on both upstream and downstream sides (up to 500 meters) and remove all construction debris and/or remnants of construction works undertaken/ completed by HPPWD contractors at all 4 bridge locations. ○ Check and undertake bed profile correction of the river/ streams, if warranted or utmost necessary, to match it natural bed profile beyond 500 meters on both upstream and 	Contractor	<p><u>Supervision:</u> Environment & Social Specialists of CSC</p> <p><u>Monitoring:</u> Environmental Specialist of HPRIDCL under the overall guidance of Project Director</p>

S. No	Project Stage/Activity	Mitigation Management Measures/GIIP Measures	Responsibility	
			Planning and Execution	Supervision/ Monitoring
		<p>downstream sides to ensure a smooth flow regime, without localized and uneven depressions on waterfront/waterway/ stream beds.</p> <ul style="list-style-type: none"> ○ Check and repair and/or restore the eroded or damaged river/ stream banks (on both sides) up to 500 meters on both upstream and downstream sides at each of the 4 locations of Associated Facilities. ○ Assess and identify appropriate bio-engineering (nature-based solutions) solutions, which can be undertaken along the river/ stream banks as a bank protection measures at Associated Facility locations. 		
BIO-DIVERSITY MANAGEMENT				
42	Construction activity along/ near forest stretches of Project Road	<p>The project road has forest areas adjacent to the right of way at eight stretches of project road, over a cumulative length of 4.255 km (ref. 4.5.2 & Table 4.18 under Section 4- Baseline Data of ESIA volume). During construction phase contractor shall adhere to the following:</p> <ul style="list-style-type: none"> • All road construction activities shall be restricted to existing right of way and forest area shall NOT be disturbed/trespassed for whatsoever reasons • NO trees within forest areas shall be disturbed, felled and/or lopped for movement of construction machinery or establishing working area within the right of way • NO dumping of construction debris shall be done in forest area • NO borrowing of earth shall be carried out from forests areas • All road construction work along the forest stretches shall be supervised so that NO workforce shall do any kind of damage to forests areas. • NO workforce shall enter the forests areas, for whatsoever reason • All workforces shall be strictly instructed to not to harm any wild animals, In case of sighting of any kind wild animals. Workforce shall be strictly instructed NOT to panic and walk away from the scene without disturbing the wild animals • All types of road construction work along forest stretches shall be limited to day light hours only and NO workforce shall remain in forests stretches after daylight hours. • Workforce shall be strictly barred from lighting of fire for whatsoever reason and use or carry inflammable materials along forest stretches. • The Contractor shall clear all temporary structures; dispose all garbage, night soils and POL (Petroleum, Oil and Lubricants) wastes as per Comprehensive Waste Management Plan and as approved by CSC. 	Contractor	<p><u>Supervision:</u> Environment & Social Specialists of CSC</p> <p><u>Monitoring:</u> Environmental Specialist of HPRIDCL under the overall guidance of Project Director</p>

S. No	Project Stage/Activity	Mitigation Management Measures/GIIP Measures	Responsibility	
			Planning and Execution	Supervision/ Monitoring
43	Bio-diversity Management (flora and fauna)	<ul style="list-style-type: none"> In order to compensate for the vegetation cleared and trees felled within right of way due to the road construction, compensatory plantation to be undertaken through planting at least 3 saplings for every tree cut with 90% survival rate with three years maintenance. Normally, such plantation work is taken up either along the project corridor or at places identified by the department of forests, GoHP in order to compensate for the trees felled. With this compensatory plantation measures, the tree cover lost could be regained in 5 to 7 years and thus the impacts could get mitigated. Only local species, which are less water consuming and approved by the forest department shall be used for plantation. Normally, all such afforestation shall be undertaken by the department of forest and maintained for three years as a deposit work accordingly cost provisions for compensatory plantation is included in ESMP Budget. In order to limit the propagation of invasive species within RoW, firstly all such invasive species within the corridor of impact and/or right of way shall be removed/cleared and replanted with local species. The department of forests, GoHP has framed a procedure for removal of invasive species and replanting of local species, which shall be duly followed. Normally, all such activities shall be undertaken by the department of forest and maintained for three years as a deposit work. Therefore, cost provision for corridor plantation is included in ESMP Budget. ESMP also include cost provisions for plantation and/or landscaping through nature based (bio-engineering solutions) of reclaimed low-lying areas within RoW to improve the aesthetics of road corridor. <p>In order to limit the impacts on the fauna due to the road construction, the following measures shall be followed:</p> <ul style="list-style-type: none"> HPRIDCL has commissioned an independent Bio-Diversity Management Study and evolve measures to manage the human-animal conflicts, (particularly Leopard) for all project corridors under Tranche I, which include this project road. The recommendations of the bio-diversity management plan shall be duly implemented by HPRIDCL. In addition, all culverts along 8 forest stretches of the project road (Table 4-18 of ESIA volume) and /or any other potential locations/stretch as recommended by bio-diversity study shall be adequately sized, to serve as animal crossing points and wildlife management measures thereof. As part of ESIA, renovation/conservation of natural water source at Km 18 has been included 	Contractor	<p><u>Supervision:</u> Environment & Social Specialists of CSC</p> <p><u>Monitoring:</u> Environmental Specialist of HPRIDCL under the overall guidance of Project Director</p>

S. No	Project Stage/Activity	Mitigation Management Measures/GIIP Measures	Responsibility	
			Planning and Execution	Supervision/ Monitoring
		<p>for conservation and rehabilitation with provision for adequate storage tanks with taps for use by local community/road users and provision of water troughs to facilitate drinking of water by wild animals, grazing and stary cattle. In addition, 5 natural water sources are also being conserved/renovated as part of enhancement measure under ESIA, out of which 3 are in rural settings, which can probably serve as water sources for wild animals, grazing and stary cattle. Design/drawings for conservation and enhancement of water sources along with adequate budgetary provisions have been included under Section 8.</p> <ul style="list-style-type: none"> • All work force shall be oriented to keep calm and walk away from the scene, in case, wild animals are sighted either during work hours at operational/work sites or at night hours at campsites. • The construction work shall be restricted to day hours only, while working established in the vicinity/nearby forest areas and work shall not be carried out in the late evening hours/night hours /early mornings • Work force shall be strictly instructed not to harm/kill and prohibited hunting of wild animals under any circumstances • The Work force shall be strictly prohibited from entering into forest areas under any circumstances. • The Construction camp and work force camp sites shall not be established in the vicinity/nearby forest areas. At least 500m distance shall be kept from such areas under unavoidable circumstances. • The camp sites and work force camps shall be access controlled and well-lit to avoid/prevent entry of wild animals. • The work force shall be oriented not to feed monkeys and /or stray animals and to properly collect waste food in dustbins to prevent menace in camp area. • HPRIDCL shall implement all recommendations of an independent study to manage the human-animal conflicts, (particularly Leopard) for all roads under HPSRTP. The study is presently under progress and the study findings and recommendations is likely to be available by April 2021. 		
44	Ancient and Historical Monuments and Chance Finds	<ul style="list-style-type: none"> • Project road corridor does not have any protected Ancient and Historical Monuments and therefore no measures are warranted. Hence, deployment of cultural heritage expert by HPRIDCL may not be warranted. • All fossils, coins, articles of value of antiquity, structures and other remains or 	Contractor	<u>Supervision:</u> Environment & Social Specialists of CSC

S. No	Project Stage/Activity	Mitigation Management Measures/GIIP Measures	Responsibility	
			Planning and Execution	Supervision/ Monitoring
		<p>archaeological interest discovered on the site (chance finds) shall be the property of the Government and shall be dealt with as per provisions of the relevant legislation.</p> <ul style="list-style-type: none"> The Contractor shall take reasonable precautions to prevent his workmen or any other persons from removing and damaging any such article or thing. The matter shall be immediately brought to CSC upon discovery of any such articles thereof and carry out the CSC instructions for dealing the same and till such time all work shall be stopped. The CSC shall report the matter to competent authorities at state or Archaeological Survey of India (ASI) through HPRIDCL and no further work shall be undertaken, until the location is cleared by competent authorities. Contractor shall recommence the work in the site, only after site is cleared and getting instructions from HPRIDCL through CSC. 		<p><u>Monitoring:</u> Environmental Specialist of HPRIDCL under the overall guidance of Project Director</p>
45	Culture/ Heritage/ Places of Religious Importance	<ul style="list-style-type: none"> Rewalsar has 4 monasteries, 1 gurudwara and 3 temples, sacred Rewalsar lake, all of which attract tourists from various parts of the states as well as country and several religious gatherings occurs in many months of the year. Hence, contractor shall exercise the following with utmost care. Ensure, traffic diversions are in place, to minimize the inconvenience to the existing road users during the road construction phase with particular religious visitors to Rewalsar. Wherever required, adequate number of uniformed traffic wardens with reflective batons shall be deployed to manage the traffic for the entire construction phase. Road construction schedule near Rewalsar shall be informed to the concerned authorities of monasteries, gurudwara and temples well in advance and avoid major construction works on religious/ auspicious dates at Rewalsar, to minimize inconvenience to religious visitors. All works between Ch. 21+000 to 23+000 near Rewalsar shall be well planned and works shall be completed in shortest possible time, with minimal inconvenience to community and tourist/ visitors. If warranted, steel barricades shall be used to minimize the inconvenience at these locations. Adequate traffic diversions near Rewalsar shall be planned with adequate number of uniformed traffic wardens with reflective batons shall be deployed to manage the traffic, to ensure safety and minimal inconvenience to users of sensitive receptors location. Dust suppression measures like regular sprinkling of water shall be carried out with more precaution near Rewalsar to ensure dust levels kept to minimum. The construction debris and spills cleared of all construction debris on a daily basis near Rewalsar. All work force shall be specifically oriented to strictly not to enter the lake area or feed the 	Contractor	<p><u>Supervision:</u> Environment & Social Specialists of CSC</p> <p><u>Monitoring:</u> Environmental Specialist of HPRIDCL under the overall guidance of Project Director</p>

S. No	Project Stage/Activity	Mitigation Management Measures/GIIP Measures	Responsibility	
			Planning and Execution	Supervision/ Monitoring
		<p>fishes and not to catch fish or do fishing of any type at Rewalsar lake.</p> <ul style="list-style-type: none"> The Construction camp and work force camp sites shall not be established in the vicinity/nearby of the Rewalsar. The work force shall be oriented not to feed monkeys and /or stray animals Ensure no conflicting situation develop/arise with the local community/stakeholders and concerned authorities of monasteries, gurudwara and temples during the entire road construction phase through a responsive communication channels and resolve any grievances through a responsive GRM and conflict management initiatives. 		
46	Environmental Monitoring	<ul style="list-style-type: none"> The Contractor shall undertake monthly monitoring of air, water, noise and soil quality covering all operational sites as well as establishment sites such as workforce camps, camp sites, crusher unit, hot mix plant among others, through an NABL accredited laboratory. The parameters to be monitored, frequency and duration of monitoring as well as the locations to be monitored shall be as per the environmental monitoring program along with cost provisions are included in section 5 & 8. 	Contractor	<p><u>Supervision:</u> Environment & Social Specialists of CSC</p> <p><u>Monitoring:</u> Environmental Specialist of HPRIDCL under the overall guidance of Project Director</p>
47	Continuous Community Participation	<ul style="list-style-type: none"> The contractor and CSC shall have an ongoing shall have continuous interactions with local community along project road through periodic interactions and ensure that the construction activities are not causing undue inconvenience to the locals residing in the vicinity of project road either due to movement of construction vehicles, traffic diversions, vibration, dust and noise levels due to construction works or due to handling of construction debris etc. The stakeholder's engagement plan shall be followed for community participation procedures. 	Contractor	<p><u>Supervision:</u> Environment & Social Specialists of CSC</p> <p><u>Monitoring:</u> Environmental Specialist of HPRIDCL under the overall guidance of Project Director</p>
CONTRACTOR'S DEMOBILIZATION				
48	Clean-up Operations, Restoration and Rehabilitation	<ul style="list-style-type: none"> Contractor shall prepare -Site Restoration Plans which shall be approved by CSC. The clean-up and restoration operations are to be implemented by the Contractor prior to demobilization. The Contractor shall clear all temporary structures; dispose all garbage, night soils and POL (Petroleum, Oil and Lubricants) wastes as per Comprehensive Waste Management Plan and as 	Contractor	<p><u>Supervision:</u> Environment & Social Specialists of CSC</p>

S. No	Project Stage/Activity	Mitigation Management Measures/GIIP Measures	Responsibility																																																				
			Planning and Execution	Supervision/ Monitoring																																																			
		<p>approved by CSC.</p> <ul style="list-style-type: none"> All establishments/sites like camp sites, workforce campsites, hot mix plants, batch mix plants for WMM and concrete, crusher units, borrow areas, muck disposal sites have to be restored as per restoration plan approved by CSC All disposal pits or trenches shall be filled in and effectively sealed off. Residual topsoil, if any shall be distributed (in a layer of 30 mm) on restored sites, adjoining/ proximate barren land or areas identified by the Contractor and approved by the CSC. All construction zones and facilities including culverts, road-side areas, camps, Hot Mix plant sites, Crushers, batching plant sites and any other area used/affected due to the project operations shall be left clean and tidy, at the Contractor's expense and restored to previous state or to the entire satisfaction of CSC. 		<p><u>Monitoring:</u> Environmental Specialist of HPRIDCL under the overall guidance of Project Director</p>																																																			
OTHER SPECIFIC CONSERVATION/RENOVATION AND ENHANCEMENT MEASURES FOR NATURAL AND CULTURAL HERITAGE RESOURCES																																																							
49	Specific conservation/renovation /enhancement measures for Natural Resources and Cultural heritage Resources along Project Road	<ul style="list-style-type: none"> ESMP include provisions for some site-specific conservation and enhancement measures along project road. The summary details are given in Figures 3-2 to 3-20 and summarized hereunder: <table border="1" style="margin-left: 40px;"> <thead> <tr> <th>Sl. No.</th> <th>Chainage</th> <th>Typology of Structure</th> </tr> </thead> <tbody> <tr><td>1</td><td>3+700</td><td>Natural Water Source (all season)</td></tr> <tr><td>2</td><td>3+999</td><td>Religious Shrine</td></tr> <tr><td>3</td><td>4+297</td><td>Dug well</td></tr> <tr><td>4</td><td>4+515</td><td>Primary health Centre</td></tr> <tr><td>5</td><td>4+773</td><td>Private School</td></tr> <tr><td>6</td><td>5+321</td><td>Religious Shrine/structure (Peepal tree with platform)</td></tr> <tr><td>7</td><td>5+989</td><td>Religious Shrine for Relocation</td></tr> <tr><td>8</td><td>8+275</td><td>Religious Shrine/structure (Peepal tree with platform)</td></tr> <tr><td>9</td><td>8+280</td><td>Natural drinking resource</td></tr> <tr><td>10</td><td>10+416</td><td>Natural water resource</td></tr> <tr><td>11</td><td>10+725</td><td>Religious Shrine</td></tr> <tr><td>12</td><td>12+482</td><td>Natural water resource</td></tr> <tr><td>13</td><td>18+048</td><td>Natural drinking water resource (all season)</td></tr> <tr><td>14</td><td>22+545</td><td>School</td></tr> <tr><td>15</td><td>22+997</td><td>Religious Shrine/structure (Peepal tree with platform)</td></tr> <tr><td>16</td><td>24+218</td><td>Religious Shrine/Structure</td></tr> </tbody> </table>	Sl. No.	Chainage	Typology of Structure	1	3+700	Natural Water Source (all season)	2	3+999	Religious Shrine	3	4+297	Dug well	4	4+515	Primary health Centre	5	4+773	Private School	6	5+321	Religious Shrine/structure (Peepal tree with platform)	7	5+989	Religious Shrine for Relocation	8	8+275	Religious Shrine/structure (Peepal tree with platform)	9	8+280	Natural drinking resource	10	10+416	Natural water resource	11	10+725	Religious Shrine	12	12+482	Natural water resource	13	18+048	Natural drinking water resource (all season)	14	22+545	School	15	22+997	Religious Shrine/structure (Peepal tree with platform)	16	24+218	Religious Shrine/Structure	Contractor	<p><u>Supervision:</u> Environment & Social Specialists of CSC</p> <p><u>Monitoring:</u> Environmental Specialist of HPRIDCL under the overall guidance of Project Director</p>
Sl. No.	Chainage	Typology of Structure																																																					
1	3+700	Natural Water Source (all season)																																																					
2	3+999	Religious Shrine																																																					
3	4+297	Dug well																																																					
4	4+515	Primary health Centre																																																					
5	4+773	Private School																																																					
6	5+321	Religious Shrine/structure (Peepal tree with platform)																																																					
7	5+989	Religious Shrine for Relocation																																																					
8	8+275	Religious Shrine/structure (Peepal tree with platform)																																																					
9	8+280	Natural drinking resource																																																					
10	10+416	Natural water resource																																																					
11	10+725	Religious Shrine																																																					
12	12+482	Natural water resource																																																					
13	18+048	Natural drinking water resource (all season)																																																					
14	22+545	School																																																					
15	22+997	Religious Shrine/structure (Peepal tree with platform)																																																					
16	24+218	Religious Shrine/Structure																																																					

S. No	Project Stage/Activity	Mitigation Management Measures/GIIP Measures				Responsibility	
						Planning and Execution	Supervision/ Monitoring
			17	24+734	Peepal tree and shrine platform		
			18	28+216	Small Temple (Lakhdata Peer)		
			19	28+415	Religious Shrine/structure (Peepal tree with platform)		
OPERATION STAGE (by Contractor During Defect Liability Period and subsequently by O & M Contractor)							
50	Monitoring Operation Performance During Defect Liability Period and subsequently by O & M Contractor	<ul style="list-style-type: none"> The CSC shall monitor the operational performance of the various mitigation/ enhancement measures carried out as a part of the maintenance of project road, after completion of widening/upgradation The indicators monitoring include the survival rate of trees, nature-based bio-engineering interventions, improved air quality, reduced noise levels, status of rehabilitation of borrow areas/restored establishment sites, and effectiveness of noise barriers, among others. 				Contractor	<u>Supervision:</u> Environment & Social Specialists of CSC <u>Monitoring:</u> Environmental Specialist of HPRIDCL under the overall guidance of Project Director
51	Maintenance of Drainage	<ul style="list-style-type: none"> HPRIDCL shall ensure that all drains (side drains and all cross drainages) are periodically cleared especially before monsoon season to facilitate the quick passage of rainwater and avoid flooding. 				Contractor	<u>Supervision:</u> Environment & Social Specialists of CSC <u>Monitoring:</u> Environmental Specialist of HPRIDCL under the overall guidance of Project Director
52	Environmental Monitoring	<ul style="list-style-type: none"> The periodic environmental monitoring parameters including ambient air quality, noise level, water quality (both ground and surface waters), soil quality in the selected locations as suggested in environmental monitoring plan (Section 5), which shall be carried out through NABL accredited laboratory. The applicable standards are given in Appendix-8. 				Contractor	<u>Supervision:</u> Environment & Social Specialists of CSC <u>Monitoring:</u> Environmental Specialist of HPRIDCL under the overall guidance of Project Director
53	Soil Erosion and	<ul style="list-style-type: none"> Visual monitoring and inspection of soil erosion at borrow areas, quarries (if closed and 				Contractor	<u>Supervision:</u>

S. No	Project Stage/Activity	Mitigation Management Measures/GIIP Measures	Responsibility	
			Planning and Execution	Supervision/ Monitoring
	Monitoring of Borrow Areas	rehabilitated), embankments and other places expected to be affected, shall be carried out once in every three months as suggested in monitoring plan(ref. Appendix-10).		Environment & Social Specialists of CSC <u>Monitoring:</u> Environmental Specialist of HPRIDCL under the overall guidance of Project Director
54	Changes in Land Use Pattern	<ul style="list-style-type: none"> Necessary hoardings shall be erected indicating the RoW boundaries and legal actions and fines for encroachment of RoW. Budgetary provisions are to be made to surveillance and control of encroachment of right of way. 	Contractor	<u>Supervision:</u> Environment & Social Specialists of CSC <u>Monitoring:</u> Environmental Specialist of HPRIDCL under the overall guidance of Project Director
55	Public awareness on Noise levels and Health Affects	<ul style="list-style-type: none"> Community at large shall be advised to construct the noise barriers such as walls, double glazed windows and tree plantation between the roads and their property. Creating Public awareness is necessary to safeguards community health along project roads due to increased traffic levels through the dissemination of information by consultations, and distribution of pamphlets during the operation stage. 	Contractor	<u>Supervision:</u> Environment & Social Specialists of CSC <u>Monitoring:</u> Environmental Specialist of HPRIDCL under the overall guidance of Project Director
Environment and Social Management Plan – Social Impacts Mitigation Action Plan during Construction Stage				
56	Loss of land due to landslides resulting from hill cutting activities	<ul style="list-style-type: none"> Assessment of loss through joint survey with CSC & NGO, revenue/district administration officials and others, as may be required on a case-by-case basis and due payment of compensation to title or non-title holder as per RPF provisions (in terms of rate determined and valuation done). 	Contractor and NGO for RAP implementation assisted by Revenue Department as required	<u>Supervision:</u> Environment & Social Specialists of CSC <u>Monitoring:</u> Environmental Specialist

S. No	Project Stage/Activity	Mitigation Management Measures/GIIP Measures	Responsibility	
			Planning and Execution	Supervision/ Monitoring
				of HPRIDCL under the overall guidance of Project Director
57	Cracks in structures or damage due to construction works e.g., hill cutting activities and/or movement of heavy construction machinery and or due to vibrations caused thereof	<p>Advance notice to community on road construction activity. The notice shall be served through posters and leaflet and physical communications as required.</p> <p>Process to be followed shall involve:</p> <ul style="list-style-type: none"> • If the structure is partially damaged and if found unviable for habitation, which shall lead to full demolition of structure. Such cases shall be compensated for full structure without depreciation as per RPF provisions • Compensation to structure owner as per RPF provisions if full structure damaged • In case of partial damage and viable for habitation, such cases be compensated for part structure and compensation shall be liberal but as per RPF provisions without any depreciation • Loss estimation shall be done as per latest BSR without depreciation. Labor charges etc. should be top up for estimated damage cost. The compensation amount may be paid to the affected person/family or the contractor shall arrange and pay for complete rectification of the structure to the satisfaction of the affected person. • Each such individual case should be documented with photographs/videography etc. 	Contractor and NGO for RAP implementation assisted by Revenue Department as required	<p><u>Supervision:</u> Environment & Social Specialists of CSC</p> <p><u>Monitoring:</u> Environmental Specialist of HPRIDCL under the overall guidance of Project Director</p>
58	Disruption in services due to shifting of utilities such as water supply, transformers, HT/LT lines, electric poles, telephone poles etc	<ul style="list-style-type: none"> • Advance information (7 days) shall be served through poster and leaflet or through personal communication (as may be required) to the likely affected people/community and make alternate arrangements for the disruption periods if it is likely to be more than 8 hours. • Restore the services within 10 days of effect. Provide alternative source of supply for intervening period. 	Contractor assisted by line departments.	<p><u>Supervision:</u> Environment & Social Specialists of CSC</p> <p><u>Monitoring:</u> Environmental Specialist of HPRIDCL under the overall guidance of Project Director</p>
59	Disruption to access from houses and shops to roads	<ul style="list-style-type: none"> • Advance information (7 days) shall be served through poster and leaflet or through personal communication (as may be required) to the likely affected household/shops/people/community/ tourist operators. 	Contractor	<p><u>Supervision:</u> Environment & Social Specialists of CSC</p>

S. No	Project Stage/Activity	Mitigation Management Measures/GIIP Measures	Responsibility	
			Planning and Execution	Supervision/ Monitoring
		<ul style="list-style-type: none"> • make alternate arrangements for the disruption period if it is likely to be more than 8 hours. • Restore permanent access equal or better than previous state. 		<u>Monitoring:</u> Environmental Specialist of HPRIDCL under the overall guidance of Project Director
60	Differential impacts on vulnerable and disadvantaged population	<ul style="list-style-type: none"> • Advance information (7 days) shall be served through poster and leaflet or through personal communication (as may be required) to the likely affected household/shops/people/community • make alternate arrangements for the disruption period if it is likely to be more than 8 hours. • Restore permanent access equal or better than previous state. • Impacted disadvantaged population shall be treated case by case basis by provision of temporary access and other assistance as identified as per RPF provisions 	NGO for RAP implementation assisted by Revenue Department as required	<u>Supervision:</u> Environment & Social Specialists of CSC <u>Monitoring:</u> Environmental Specialist of HPRIDCL under the overall guidance of Project Director
61	Dust emissions during construction leading to impacts on crops and trees	<ul style="list-style-type: none"> • Advance information (7 days) shall be served through poster and leaflet or through personal communication (as may be required) to the likely affected farmers/households//people/community • Monitor for visible dust levels through EHS officer of Contractor • Initiate precautionary measures for dust control like periodic water sprinkling at predetermined frequency and controlled movement of construction vehicles and machinery • Keep communication channels open with community and redress their grievances at earliest possible time in a reasonable manner and/acceptable to CSC 	Contractor	<u>Supervision:</u> Environment & Social Specialists of CSC <u>Monitoring:</u> Environmental Specialist of HPRIDCL under the overall guidance of Project Director
62	Likelihood of increased accidents due to road widening (including at sensitive receptor locations such as	<ul style="list-style-type: none"> • Adequate road signage/road marking/rumble strip/glow sign board to be provided. • Barricading the construction area and with LED lighting facility at night hours • Adequate traffic diversion • Community level consultations including school authorities as well as school children • Prior intimation in school and communities living in the vicinity adopting for safety measures • Plan and swiftly complete the construction work in settlements areas and near sensitive 	Contractor	<u>Supervision:</u> Environment & Social Specialists of CSC <u>Monitoring:</u> Environmental Specialist of HPRIDCL under the

S. No	Project Stage/Activity	Mitigation Management Measures/GIIP Measures	Responsibility	
			Planning and Execution	Supervision/ Monitoring
	schools, hospitals)	receptors <ul style="list-style-type: none"> Ensure the construction work near settlements areas and sensitive receptor locations have adequate measures to ensure community safety 		overall guidance of Project Director
63	Possibility of GBV (gender-based violence) arising due to influx of migrant labour/construction workers	<ul style="list-style-type: none"> To address this, contractor shall prepare a GBV Risk Mitigation Strategy in accordance with GBV risk Mitigation Strategy of HPRIDCL and it shall comprise: - Creating awareness about GBV related issues among workers during engagement and/or during Induction and signing of Code of Conduct for GBV related issues wither at workforce camps and or community hotspots like nearby market areas frequented by workers after work hours and/or weekly off days, schools, vocational training centers, liquor shops and, migrant workers residing in rented accommodations within the villages/settlement areas Integrate briefings on GBV into existing IEC strategy/materials, GRM, induction training, safety talks, toolbox meetings, tailgate sessions and regular trainings. Mapping of service providers for GBV prevention including surveillance at hot spots and closely monitor throughout the project cycle. Prepare and Implement Labour Influx Management Plan by Contractor ó This shall be prepared by contractor prior to commencement of civil works Create awareness of labor supplier contractor in all labour laws, GBV risks and mitigation strategy as part of contractorø LMP The GBV risk mitigation plan shall also include: <ul style="list-style-type: none"> Awareness programmes on GBV in communities: Since the GBV consultations during ESIA highlight that most of the women are illiterate and have no knowledge of GBV, awareness programmes like nukadnatak and pictorial posters should be developed for raising community awareness on GBV prevention and response. Linkages with the police: The GBV consultations during ESIA noted that there were some reported cases of IPV and of GBV due to labour influx, which were resolved with the help of the police. The contractor/ CSC/ CMU needs to organize some local events linking the police with the community for effective redressal of incidents. Monthly meetings with women: Since the consultations noted that there are no MMs or SHGs in the villages, monthly meetings should be organized with the support of the panchayat and /or frontline workers (like the Anganwadi or Asha workers) for discussing these issues and sharing information. Since a majority of the women reported being very busy with household chores, particularly due to fetching water for drinking and domestic 	Contractor and NGO for RAP implementation	<u>Supervision:</u> Environment & Social Specialists of CSC <u>Monitoring:</u> Environmental Specialist of HPRIDCL under the overall guidance of Project Director

S. No	Project Stage/Activity	Mitigation Management Measures/GIIP Measures	Responsibility	
			Planning and Execution	Supervision/ Monitoring
		<p>use, meetings should be organized taking into consideration their convenience.</p> <ul style="list-style-type: none"> ○ Multiple channels for grievance redressal need to be identified for reporting and response of GBV incidents. 		
64	Likelihood of spread of HIV/AIDS among construction workers and roadside community	<ul style="list-style-type: none"> • Coordinate with State AIDS control society for dissemination materials amongst construction workers including creating awareness, education and Program convergence • Make provisions for availability of condoms at convenient locations including installation of condom vending machines at labour camp, community-based meetings, consultations in camp, distribution of leaf let, IEC communication, posters, banners 	Contractor and NGO for RAP implementation	<p><u>Supervision:</u> Environment & Social Specialists of CSC</p> <p><u>Monitoring:</u> Environmental Specialist of HPRIDCL under the overall guidance of Project Director</p>

5. ENVIRONMENTAL MONITORING PROGRAMME

5.1 General

37. The monitoring and evaluation are critical activities in implementation of the Project Monitoring involves periodic checking to ascertain whether activities are going according to plan or not. It provides the necessary feedback for project management to ensure that the project objectives are met and on schedule.

38. The reporting system is based on accountability to ensure that the environmental mitigation measures are implemented.

39. Environmental monitoring program has the underlying objective to ensure that the intended environmental mitigations are realized and these results in desired benefits to the target population causing minimal deterioration to the environmental parameters. Such program targets proper implementation of the ESMP.

40. The broad objectives are:

- To evaluate the performance of mitigation measures proposed in the ESMP.
- To evaluate the adequacy of environmental assessment.
- To suggest ongoing improvements in management plan based on the monitoring and to devise fresh monitoring based on the improved ESMP.
- To enhance environmental quality through proper implementation of suggested mitigation measures.
- To meet the requirements of the existing environmental regulatory framework and community obligations.

5.2 Performance Indicators

41. Environmental components identified of a significance in affecting the environment at critical locations have been suggested as performance indicators (PIs). For example, near the construction site, a thick layer of dust over the nearby vegetation/leaf is an indication that the dust control measures are not effective. The performance indicators shall be evaluated under three heads as;

- Environmental condition indicators to determine efficacy of environmental management measures in control of air, noise, water and soil pollution.
- Environmental management indicators to determine compliance with the suggested environmental management measures.
- Operational performance indicators have also been devised to determine efficacy and utility of the proposed mitigation measures.

42. The performance indicators and monitoring plans prepared for the Mandi-Rewalsar-Kalkhar road section are presented in Table 5-1. Details of the performance indicative parameters for each of the component have to be identified and reported during all stages of the implementation.

Table 5-1: Performance Indicators

S No.	Description of Item	Indicator	Stage	Responsibility
1	<ul style="list-style-type: none"> No. of Borrow Areas identified and verified No. of sites for which Restoration Plans have been prepared No. of Site Restored and Rehabilitated No. of Sites handed over 	Borrow Area and Quarries	Pre-Construction	Contractor
2	<ul style="list-style-type: none"> No. of Quarry Areas identified & verified No. of sites Restoration Plans are required and have been prepared No. of Site Restored and Rehabilitated No. of Sites handed over 	Borrow Area and Quarries	Pre-Construction	Contractor
3	Quantity of Debris and Spoils to be disposed off <ul style="list-style-type: none"> No. of locations Approved for Debris disposal Quantity disposed off at each location No. of locations for which Rehabilitation works have been completed 	Disposal sites	Construction	Contractor
4	<ul style="list-style-type: none"> No. of location/s identified for the Construction camp and Construction Plant sites No. of location/s approved Lay-out/s Approved No. of sites for which Site Restoration and Rehabilitation has been completed 	Construction Camps and Plant Sites	Pre-Construction	Contractor
5	<ul style="list-style-type: none"> No. of Trees to be Cut No. of Trees cut % Progress on the tree removal 	Tree cutting	Pre-Construction	CSC/CMU/HPRIDC
6	No. of Locations identified for temporary storage areas for storage of the excavated materials to be used in embankment and sub grade	Storage of excavated materials	Pre-Construction and Construction	Contractor
7	Before the onset of monsoon all the debris/excavated material shall be cleaned from the work sites and disposed of at the pre-identified approved locations.	Silting of Water bodies	Construction	Contractor
8	Implementation of enhancement measures for <ul style="list-style-type: none"> Noise Barrier at sensitive locations 	Enhancements	Construction	Contractor
9	Drainage <ul style="list-style-type: none"> Length (by type) No. of Locations 	Work sites	Construction	Contractor
10	Safety Provisions <ul style="list-style-type: none"> Signage (by type and no.) Crash barriers footpath 	Work sites	Construction	Contractor
11	Soil erosion prevention measures <ul style="list-style-type: none"> Construction of retaining walls 	Work sites	Construction	Contractor

S No.	Description of Item	Indicator	Stage	Responsibility
	<ul style="list-style-type: none"> Downstream at culvert locations (No. of Locations & length) 			
12	No. of HIV awareness sessions conducted	-	Construction	Contractor
13	No. of safety awareness sessions conducted	-	Construction	Contractor
14	Accidents <ul style="list-style-type: none"> No of accidents recorded 	Along project road	During construction	Contractor
15	Environmental parameter monitoring in accordance with the frequency and duration of monitoring as well as the locations as per the Monitoring Plan given in Table 5-2	Air Quality Noise Quality Soil Quality Water Quality	Construction and Operation	Contractor through NABL Accredited agency.
16	<ul style="list-style-type: none"> No. of Training Sessions Organised for <ul style="list-style-type: none"> i. Departmental Staff ii. Contractors iii. Combined No. of People Trained <ul style="list-style-type: none"> iv. Departmental Staff v. Contractors 	Training Imparted	Construction /Operational face	CSC/CMU/ HPRIDC
17	No. of awareness sessions for educating the public about road safety and other environmental aspects (Such as waste dumping, preservation of enhanced sites, pollution and health impacts etc.)	-	Construction/ Operation Stage	CSC/CMU/ HPRIDC
18	No. of Trees Planted (Total) <ul style="list-style-type: none"> No. of Trees under Compensatory Afforestation No. of Trees Planted along Roadsides No. of Trees planted at other locations (such as camps, borrow areas, debris disposal sites and plant areas) No. of trees planted at enhancement sites 	Roadside and other plantation areas	Post construction stage	Forest Department and ESMU
19	Survival Rate Trees Planted (Average) <ul style="list-style-type: none"> Compensatory Afforestation Roadside Plantation Other locations (such as camps, borrow areas, debris disposal sites and plant areas) Enhancement sites 	Roadside and other plantation areas	Post construction stage	Forest Department and ESMU

5.3 Monitoring Plan for Environmental Conditions

43. For each of the Environmental Conditions, the Monitoring Plan specifies the parameters to be monitored, location of the monitoring sites, frequency and duration of monitoring. The monitoring plan also specifies the applicable standards, implementation and supervising responsibilities. The monitoring plan and

details of monitoring locations for environmental condition indicators of the project during the construction and operation stage are presented in **Table 5-2**.

44. The monitoring will be carried out by Contractor through the NABL approved agency and will be supervised by the Environment Specialists of the CSC and HPRIDCL.

Table 5-2: Environmental Monitoring Plan for Air, Water, Noise and Soil

Attribute	Timing	Parameter	Special Guidance	Standards	Frequency	Duration	Location	No of Samples	Implementation Responsibility
Air	Construction	CO, NO _x , PM10, PM2.5 and SO ₂	High Volume sampler to be located 50 m from the plant in the down wind direction. Use method specified by CPCB for Analysis	CPCB Guidelines (NAAQMS/ Volume-I/2013-14)	Every month at 4 locations	24 hours sampling	A location covering sensitive receptor, work force camp, camp sites and construction/ operational sites along the project road	120	Contractor
	Operation						Roadside		
Water	Construction	As per Drinking Water Standards	Grab sample collected from source and analyse as per standard methods for examination	Indian standards for inland surface waters (IS:2296,1982) and for drinking water (IS:10500-2012)	Every month at 2 locations	As per Grab Sampling guidelines	2 locations covering drinking water samples from the labour camps and from hand pumps Surface water from the water courses near the work sites and streams.	60	Contractor
	Operation						Natural Surface water sources		
Noise	Construction	Noise Levels on dB (A) scale	Equivalent noise levels using, and integrated noise level meter kept at 15 m from edge of pavement	Noise rules 2000 by CPCB	Every month at 4 locations	Leq in dB(A) of daytime and night-time	A location covering sensitive receptor, work force camp, camp sites and construction/ operational sites along the project road	120	Contractor

Attribute	Timing	Parameter	Special Guidance	Standards	Frequency	Duration	Location	No of Samples	Implementation Responsibility
	Operation				Once every season for 3 year after completion of construction activity/ including DLP		Sensitive receptors locations along the project road		CMU
Soil	Construction	Monitoring of Pb, SAR and Oil and Grease	Sample of soil collected to acidified and analysed using absorption spectrum	(IS): 2720 for 'Method of Test for Soils'	During the pre & post monsoon season each year	Grab Sampling	Construction Camp/ plant sites & productive agricultural lands abutting traffic detours and traffic diversions and major intersections.	60	Contractor
	Operation						Edge of right of way/ agricultural lands along the road Side		CMU

5.4 Reporting System

45. Reporting system for the suggested monitoring programme operates at two levels:

- Reporting for environmental condition indicators and environmental management indicators
- Reporting for operational performance indicators at the CSC level.

46. Environmental monitoring involves regular checking of the environmental management issues detailed in the EMP and to ascertain whether the mitigation measures are achieving their objectives, according to the EMP, with the progress of the works. It provides the necessary feedback for Project management to keep the programme on schedule.

47. The Contractor, CSC will operate the reporting system for environmental conditions and environmental management indicators. The reporting system is presented in **Table 5-3**. Reporting formats for Contractors have been prepared, which will form the basis of the implementation by the Contractor and monitoring by the CSC under the overall guidance of the Project Director cum Chief Engineer of HPRIDCL. The list of reporting formats (refer **Appendix-7**) prepared for the implementation of ESMP is presented in **Table 5-4**.

- The reporting system will start with the Construction Contractor who is the main executor of the implementation activities. The Contractor will report to the Construction Supervision Consultant, who in turn shall report to the HPRIDCL.
- The Contractor will submit monthly and quarterly environmental compliance reports along with formal monthly and quarterly reporting to the CSC.
- The CSC will submit separate quarterly environmental monitoring reports to HPRIDCL in addition to submission of the summary of the activities of the month in the formal monthly report including any deviations and corrective actions
- CSC will be responsible for the preparation of the targets for identified non-compliances.
- Solutions for further effective implementation may also emerge as a result of the compliance monitoring reports.
- Environmental Management Compliance Certificate will be issued by Environment Specialist of HPRIDCL during the submission of each Interim Payment Certificate (IPC). This certificate will be based on compliance status of environmental measures during that tenure for which IPC has been produced (ref. **Appendix-13**).
- Photographic records will be kept to provide useful environmental monitoring tools. All material source locations, debris disposal locations, plantø locations, Construction camp locations, Crusher locations etc. will have a complete photographic record. Photographs for all these establishments will be taken prior to establishment activities begin, during the establishment and operation process and after rehabilitation. The record will be submitted to CSC half yearly and will also be availed to CMU and HPRIDCL as and when required.
- A full record of construction activities will be kept as a part of normal Contract monitoring system.
- The operation stage monitoring reports may be annual, provided the Project Environmental Completion Report shows that the implementation was satisfactory.

48. This reporting will be as follows:

- Reporting by the Contractor to the CSC.
- Reporting by CSC to HPRIDCL.
- Reporting by HPRIDCL for the information of all interested parties.

Table 5-3: Reporting System

Items	Contractor	Construction Supervision Consultant		HPRIDC		World Bank (WB)
	Implementation & Reporting to CSC	Supervision	Reporting to HPRIDC	Oversee Compliance Monitoring	Report to WB	Desired Supervision
Construction Stage						
Monitoring of Construction Site and Construction Camp	Before start of work	Regular	Monthly	Monthly	Quarterly	Half Yearly
Pollution Monitoring	Monthly	As required	Monthly	Monthly	Quarterly	Half Yearly
Debris Disposal Area	Weekly	Regular	Monthly	Monthly	Quarterly	Half Yearly
Monitoring of Enhancements	Implementation	As required	Monthly	Monthly	Quarterly	Half Yearly
Topsoil Preservations	Weekly	As required	Monthly	Monthly	Quarterly	Half Yearly
Borrow Area/Quarry Area/Debris Disposal Area	Regular	As required	Monthly	Monthly	Quarterly	Half Yearly
Tree Cutting	As required	As required	Monthly	Monthly	Quarterly	Half Yearly
Tree Plantation	As required	As required	Monthly	Monthly	Quarterly	Half Yearly
Operation Stage						
Pollution Monitoring	As required	As required	Monthly	As per monitoring plan	Quarterly	Half Yearly

Table 5-4: Summary Details of Reporting Formats

Format No.	Item	Stage	Contractor	Construction Supervision Consultant (CSC)	
			Implementation & reporting to CSC	Supervision	Reporting to HPRIDC
RF 1	Approval of Construction Camp/ Plant Site and its Management Plan	Pre-Construction	One Time	One Time	One Time
RF 2	Approval of Borrow Management Plan (General & Specific)	Pre-Construction	General -One Time Specific re-development plan - one for each borrow area	Regular	Monthly
RF 3	Construction Camp and Plant Site Management	Construction	Monthly	Regular	Monthly
RF 4	Topsoil Management	Construction	Monthly	Regular	Monthly
RF 5	Pollution Control and Construction Plants	Construction	Monthly	Regular	Monthly
	Pollution Monitoring	Construction and Operation	As required	As required	Monthly

Format No.	Item	Stage	Contractor	Construction Supervision Consultant (CSC)	
			Implementation & reporting to CSC	Supervision	Reporting to HPRIDC
RF 6	Vehicles and Pollution Control	Construction	Monthly	Regular	Monthly
RF 7	Details of the DG Sets and Pollution Control	Construction	Monthly	Regular	Monthly
RF 8	Details of Oil Storage	Construction	Monthly	Regular	Monthly
RF 9	Working at Water Courses & Pollution Control	Construction	Monthly	Regular	Monthly
RF 10	Details of Water Extraction	Construction	Monthly	Regular	Monthly
RF 11	Details of Personal Protective Equipment	Construction	Monthly	Regular	Monthly
RF 12	Status of Consent for Water Extraction	Construction	As required	As required	Monthly
RF 13	Deviations and Corrective Actions	Construction	As required	Monthly	Monthly
RF 14	Implementation of Enhancement Measures for Cultural Properties, Water Harvesting Structures	Construction	Monthly	Regular	Monthly
RF 15	Debris generated by the hill ward side widening, cutting of hill slopes	During construction	Throughout the construction period during widening	Regular	Monthly
RF 16	Grievance Redressal Mechanism during Construction	During Construction	Monthly	Regular	Monthly
RF 17	Work Force Management	During Construction	Monthly	Regular	Monthly
RF 18	Occupational Health Safety Measures	During Construction	Monthly	Regular	Monthly
RF 19	Road Safety Measures	During Construction	Monthly	Regular	Monthly
RF 20	Accidents Reporting	During Construction	With in 24 hrs	Regular	With in 24 hrs
RF 21	Monthly Reporting	During Construction	Monthly	Regular	Monthly (as an annexure to MPR)

49. The Environment Specialist of CSC in consultation with Environmental Specialist of HPRIDC can make required changes in the formats specified in appendices of ESMP to ensure effective reporting of environmental issues. For making any required changes in the frequency of reporting and change in the contents of the report for effective and simple for implementation and monitoring, CSC should discuss the reporting formats with the Contractor and HPRIDC. This will not only ensure that the environmental provisions are addressed but also link the satisfactory compliance to environmental procedures prior to approval of the Interim Payment Certificate (IPC) by the Engineer. In the regular monthly meeting, the environmental aspects should also be discussed and the staff responsible for the implementation of the environmental management from the Contractor, CMU and CSC should also be present.

5.5 Institutional Arrangements for ESMP Implementation

50. Institutional arrangements for implementation of ESMP have an objective to achieve environmentally as well as socially sustainable project activities under HPSRTP as well as to meet the World Bank ESS (Environment and Social Standards), which concurrently also will enable that to comply with the GoI as well as GoHP regulations during the pre-construction, construction and operational phases of HPSRTP. The ESMP implementation arrangements will also ensure to comply with loan covenants as specified by the various conditions of loan agreement between the World Bank and the GoHP.

51. The institutional arrangement/ organization structure for implementation of ESMP is given in **Figure 5-1**. The implementation of ESMP will be overseen at HPRIDCL by the Project Director cum Chief Engineer, who is also responsible for the successful implementation of all project activities under HPSRTP.

52. The Project Director (PD) will be assisted by Construction Supervision Consultant (CSC) for implementation of ESMP at each of the contract package levels. The CSC shall provide one Environmental Specialist, one Social Development Specialist and one Bio-Engineering Specialist for implementation of ESMP and shall coordinate with the Environmental Specialist at HPRIDCL headquarters for the implementation of ESMP for all the contract packages under the overall guidance of Project Director.

53. At specific project road corridor or contract package level, the Contractor shall provide one Social cum Community Liaison Officer, one Health & Safety Officer and one Environmental Officer, who shall be responsible for implementation of ESMP at field level under the guidance of the CSC.

54. The HPRIDCL has already appointed an NGO for implementation of RAP for all 4 Tranche I corridors including project road. The NGO will provide required Social Development Officer and other field staff, and coordinate with revenue departments and district administration as well as with CSC for effectively implementing the RAP provisions in accordance RPF and ensure timely disbursement of compensation/ entitlements prior to clearing of encroachments. The NGO shall also coordinate with CSC in timely handling over the encumbrance free stretches to the contractor for commencement of construction.

ESMP Implementation Monitoring and Reporting

55. The ESMP implementation monitoring, and reporting shall be through daily, weekly and monthly progress reports. The monthly reports shall further consolidate into quarterly, half yearly and annual consolidated reports. The checklists for monitoring the ESMP implementation shall be developed by CSC, based on the approved C-ESMP of the Contractor, prior to commencement of Construction works.

56. The ESMP implementation progress monitoring shall capture status of ESMP measures, implemented by contractor and shall list compliance(s) and non-compliance(s) to respective measures as well as compliance(s) to consent conditions stipulated by HPSPCB. The report shall include a list of Actions to be Taken and Action Taken Report by the contractor, which shall also be monitored by the CSC. The periodic progress report(s) shall cover all operational areas as well as designated work camp sites, hot mix plants, material stack yards along with the periodic environmental monitoring carried out covering all such operational areas, where work is under progress and establishment sites as may be required.

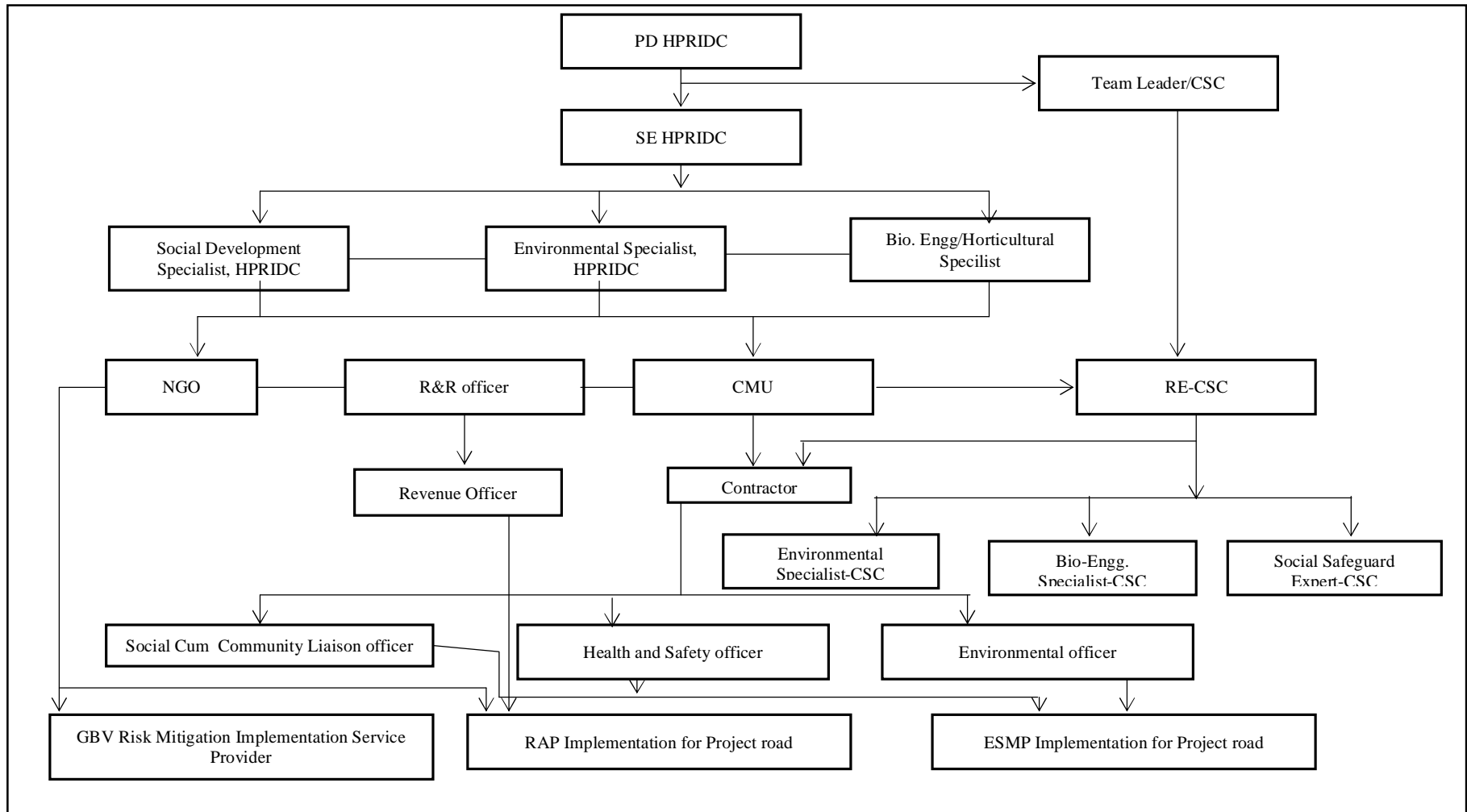

Figure5-1: Institutional arrangements for Implementation of Environmental and Social Management Plan (ESMP & RAP)

5.6 Training and Capacity Building

57. As a training and capacity building initiative, designated HPRIDCL staff will be deputed for exposure visits to other similar road construction projects with good track record for RAP and ESMP implementation. The HPORDC and CSC staff will also be sponsored for training courses conducted by accredited institutions in Resettlement and Rehabilitation (R&R) and ESMP implementation, if warranted.

5.7 Grievance Redress Mechanism

58. HPRIDCL will establish GRM at each contract package level; which resolve complaints/ grievances from both PAPs/PAFs, to redress the complaints arising due to on-site verification of PAPs/PAFs, determination of applicable entitlements, disbursements of entitlements during implementation of RAP, of which will be largely completed during pre-construction phase.

59. The same GRM (through sub-committee) will also address the complaints received during the project construction phase, which could be mainly arising due to construction activities of contractor like loss of access, damage to some private or common property or utilities, vibration, noise and dust levels due to excavation works, inadequate/inappropriate diversions, traffic mis-management, community safety and other similar issues/concerns. Some of the PAPs/PAHs may also become grieved/ complainants during construction phase.

60. The GRM will be independent as per respective mandates and function under CMU/ HPRIDCL. The institutional arrangements, procedure for receiving complaints, time limits for redressal of complaints are as stipulated in the stakeholder engagement plan (SEP) under for HPSRTP.

61. In addition, the contractor will be contractually obligated to set up another GRM, mainly to redress complaints relating to workforce, deployed for project road construction, in accordance with the labor management procedure (LMP) under HPSRTP.

62. The GRM to be set up by the Contractor will have designated institutional arrangements, procedure for receiving complaints, time limits for redressal of complaints, of which, will be detailed in C- ESMP, to be submitted by the contractor and approved, prior to commencement of works.

63. The contact details/information for lodging grievances, inquiries, and further feedback under project road as well as any project intervention under HPSRTP is given in **Table 5-5** hereunder. Notifications regarding constitution of committees by HPRIDCL would be done prior to award of works by HPRIDCL and the details will be notified prior to commencement of construction at the prominent community locations and also in the villages en-route along project corridors. Additionally, all such details would also be displayed in the micro-plans (prepared for provision of R&R assistances) that would be displayed in the project affected villages, along project corridors under HPSRTP.

Table 5-5: Contact Details for Lodging Grievances and Feedback under HPSRTP

Description	Contact details
Name of Authority:	Himachal Pradesh State Road & Infrastructure Development Corporation Limited (HPRIDCL)
Contact Person /Designated Authority	Chief Engineer-cum-Project Director
Address:	HP State Roads Project, HPRIDCL, NirmanBhawan, Nigam Vihar, Shimla 6 171 002, Himachal Pradesh

Description	Contact details
E-mail:	pdsrp-hp@nic.in
Website:	http://www.himachalservices.nic.in/hpridcl
Telephone:	Tel: 0177 6 2627602, 2620663
Fax:	0177 6 2620663

6. EMERGENCY RESPONSE PLAN

6.1 Introduction

60. Road Construction sites, construction camps, labour camps are the places prone to different kind of emergencies and should have Emergency Response Plan, so that quick and effective action can be taken in the event of a problem to ease the severity of the situation and to limit the consequences.

An emergency plan comprises agreed, recorded and rehearsed strategies, enabling those on site to respond effectively and reliably. Based on project location and various activities taken up during project execution different types natural and manmade risks/hazards (but not limited to) have been identified. These hazards are; Earthquake, Landslides, Floods, Fire at workplaces, Electrical accidents, Physical and Occupational Health & Safety and Hazardous material/wastes or oil spill.

6.2 Risk Assessment

61. The objective of the risk assessment study is to identify and quantify the major hazards; the risk associated with various operations of the proposed project, which may lead to emergency consequences (disasters) affecting the public safety and health. Following is the risk assessment matrix (table 6-1) to establish the potential risk of the identified hazard. The potential risks associated with each type of hazards have been established and provided in table 6-2. Controlled measures for identified risk are given in Table no 6-3.

Table 6-1: Risk Assessment Matrix

Consequences		Likelihood		Risk																																																		
5	Severe: Death or Permanent disability to one or more persons	A	Almost certain: Expected to occur in most circumstances	<table border="1"> <thead> <tr> <th colspan="2"></th> <th colspan="5">Consequences</th> </tr> <tr> <th colspan="2"></th> <th>1</th> <th>2</th> <th>3</th> <th>4</th> <th>5</th> </tr> </thead> <tbody> <tr> <td rowspan="5">Likelihood</td> <td>A</td> <td>M</td> <td>H</td> <td>H</td> <td>VH</td> <td>VH</td> </tr> <tr> <td>B</td> <td>M</td> <td>M</td> <td>H</td> <td>H</td> <td>VH</td> </tr> <tr> <td>C</td> <td>L</td> <td>M</td> <td>H</td> <td>H</td> <td>VH</td> </tr> <tr> <td>D</td> <td>L</td> <td>L</td> <td>M</td> <td>M</td> <td>M</td> </tr> <tr> <td>E</td> <td>L</td> <td>L</td> <td>M</td> <td>M</td> <td>M</td> </tr> </tbody> </table>								Consequences							1	2	3	4	5	Likelihood	A	M	H	H	VH	VH	B	M	M	H	H	VH	C	L	M	H	H	VH	D	L	L	M	M	M	E	L	L	M	M	M
												Consequences																																										
						1	2	3	4	5																																												
				Likelihood	A	M	H	H	VH	VH																																												
					B	M	M	H	H	VH																																												
					C	L	M	H	H	VH																																												
D	L	L	M		M	M																																																
E	L	L	M		M	M																																																
4	Major: Hospital admission required	B	Likely: will probably occur in most circumstances																																																			
				3	Moderate: Medical treatment required	C	Possible: Might occur occasionally																																															
								2	Minor: first aid required	D	Unlikely: Could happen at some time																																											
												1	Insignificant: Injuries not requiring first-aid	E	Rare: May happen only in exceptional circumstances																																							

L- Low; M- Medium; H- High; VH- Very High

Table 6-2: Potential Risks Associated with different Types of Hazards

Hazards	Likelihood	Consequences	Risk
Earthquake (The project lies in high damage risk zone, as per seismic area zoning map of the state)	D	4	H
Landslide (Project area falls in High risk zone of landslide (as per HP-State Disaster Management Authority)	D	3	M
Floods (Presence of two river streams along project roads poses a threat of flooding)	D	2	L
Fire at working places/material store yard etc.	E	4	M
Electrical	D	5	M
Hazardous Material or Oil spill	D	4	M
Physical/ Occupational Safety and Health	C	4	H

Table 6-3: Controlled Measures for /Identified Risks:

Hazards	Task/Scenario	Associated Harm	Control Measures
Earthquake	Construction Phase Operation Phase	Injuries Human Life Infrastructure collapse	<ul style="list-style-type: none"> Educate workers on do's and don'ts during and after earthquake (through trainings and mock drills). Safety measures like first-aid, emergency contacts, other dept. etc. to be maintained
Landslide	Construction Phase Operation Phase	Injuries Human Life Infrastructure collapse	<ul style="list-style-type: none"> Provision of Trainings and Awareness programmes Have an emergency kit ready and necessary communications facility in construction/working sites.
Fire at Working Places/Material Store yard etc.	Short-Circuits Combustible Materials Fuel Storage	Injuries Economic loss Human life Infrastructure damage	<ul style="list-style-type: none"> Personnel orientation/ awareness sessions Fire-fighting equipment of sufficient numbers to be kept. Safety measures like fire extinguishers, sand buckets, fire blankets etc. to be kept at prominent places. Staff training and mock drills to be conducted. Emergency fire exits to be maintained.

Hazards	Task/Scenario	Associated Harm	Control Measures
Electrical	Construction and Operation Phases	Injuries Human life	<ul style="list-style-type: none"> • Personnel orientation/ awareness sessions • Electrical cables and lighting works to be done at a specified place/area. • Proper grounding works to avoid static electricity build up. • Certified appliances to be tried and tested before use. • Use of intrinsically safe electrical installations and non-sparking tools
Hazardous Material or Oil Spill.	Construction Phase (while handling material)	Injuries Human life	<ul style="list-style-type: none"> • Personnel orientation/ awareness sessions • Ensure safe handling, storage, use and disposal of hazardous materials • During the complete construction phase, an estimated 104 used batteries are likely to be discarded, which are to be disposed of in accordance with the battery management rule. • The hazardous waste generated at camp sites is to be collected in steel drums and stored in a segregated roofed area and periodically disposed at approved waste disposal facilities by HPSPCB. The discarded batteries shall be disposed only through authorized recyclers from HPSPCB
Physical/ Occupational Safety and Health	Collisions, Lifting operations, Noise, Material handling, Welding operations	Injuries Human Life	<ul style="list-style-type: none"> • Personnel orientation/ awareness sessions • Implement strict use of PPE • Rotation of workers, use of better hand tools, equipment uses for stacking and movement of goods • Proper ventilation and entry/exit signs to be placed <p>Ref Appendix -12</p>

General rules/guideline for Emergency Response Mechanism to be followed by Contractor;

To deal with any types of emergency in project following procedures/setup will be followed.

- There will be an EHS induction room in the Construction camp area. This room will also act as emergency control room. Environmental and Health & Safety Officer will conduct all sorts of required trainings and awareness programmes in the induction room.
- An area will be identified and marked as an assembly area. Preferably, assembly area should be a raised point in the camp premises and should be clear from all hindrances and easily accessible to vehicles.
- A hooter/siren will be placed near assembly area, blowing of which will indicate that there is an emergency, and everybody must gather at assemble area. If hooter or siren is not working, then guards or other workmen are required to shout to alarm about incident.

- Trainings and awareness programme on various types of emergencies, preparedness (mock drill) and on rescue needs to be organized by Contractor. If some additional hazard other than already identified is noticed, then a training on that will also be imparted to workmen.
- Information Boards will be displayed near labour camp, outside office work area/ laboratory/ store area and assembly area, which will have list of the emergency contact numbers (follow table no 6-4).
- Different signage marked with exit routes must be displayed in the camp premises.
- Suitable and enough Fire extinguishers and sand buckets will be placed at applicable areas in the Camp.
- First aid box will be provided at fixed locations (store yard, laboratory, Office, labour camp and all other identified working units) to provide first aid in case of injury.
- Workers will be trained regularly for first aid training and CPR procedures.
- Third party checking of the tools and tackles will be ensured by contractor.
- Emergency contact details (Personnel of Contractor, CMU, CSC and different govt. departments) will be shared with workmen.
- Supervisor or any other workmen on site will communicate with desired people and will inform about emergency. Driver of the emergency vehicle deployed by the Contractor will be called up for rescue. The emergency contact details will also be shared to these people on site and Supervisor or any other workmen will contact required personnel/department for any help. First aid kit will also be provided to at all construction zones.

Table 6-4: Display board with emergency contact numbers:

Sr No	Name of person/ department	Telephone no
1	Contractor's Project Manager	í í í í í í .
2	Contractor's Environment Officer	í í í í í í .
3	Contractor's Safety Officer	í í í í í í .
4	Executive Engineer, PIU	í í í í í í .
5	Environmental Specialist, CSC	í í í í í í .
6	EHS Officer, CSC	í í í í í í .
7	Nearby Fire Station	í í í í í í .
8	Nearby Police Station	í í í í í í .
9	Nearby Hospital	í í í í í í .
10	Ambulance	í í í í í í .
11	Forest Department	í í í í í í .
12	Fire Station	í í í í í í .
13	Driver (Vehicle attached for emergency)	

7. ENVIRONMENTAL, SOCIAL, HEALTH AND SAFETY REQUIREMENTS

7.1 POLICY ON ENVIRONMENTAL AND SOCIAL ASPECT

HPRIDC works policy on environmental and social aspect (statement) shall apply

This policy shall be enhanced for climate adaptation, land acquisition and resettlement, indigenous people, etc. The policy should set the frame for monitoring, continuously improving processes and activities and for reporting on the compliance with the policy.

Applicable policy requirement is set out the commitments to:

- apply good international industry practice to protect and conserve the natural environment and to minimize unavoidable impacts;
- provide and maintain a healthy and safe work environment and safe systems of work;
- protect the health and safety of local communities and users, with particular concern for those who are disabled, elderly, or otherwise vulnerable;
- ensure that terms of employment and working conditions of all workers engaged in the Works meet the requirements of the ILO labour conventions to which the host country is a signatory;
- be intolerant of, and enforce disciplinary measures for illegal activities. To be intolerant of, and enforce disciplinary measures for GBV, inhumane treatment, sexual activity with children, and sexual harassment;
- incorporate a gender perspective and provide an enabling environment where women and men have equal opportunity to participate in, and benefit from, planning and development of the Works;
- work co-operatively, including with end users of the Works, relevant authorities, contractors and local communities;
- engage with and listen to affected persons and organisations and be responsive to their concerns, with special regard for vulnerable, disabled, and elderly people;
- provide an environment that fosters the exchange of information, views, and ideas that is free of any fear of retaliation, and protects whistle blowers;
- minimise the risk of HIV transmission and to mitigate the effects of HIV/AIDS associated with the execution of the Works;

7.2 MINIMUM CONTENT OF ESHS REQUIREMENTS

Detailed specifications for ESHS requirements are given hereunder:

For ESIA – refer: (Sec-VII) Part-C ESMP Requirements.

- project reports e.g. ESIA/ESMP
- consent/permit conditions

- required standards including World Bank Group EHS Guidelines
- relevant international conventions or treaties etc., national legal and/or regulatory requirements and standards (where these represent higher standards than the WBG EHS Guidelines)
- relevant international standards e.g. WHO Guidelines for Safe Use of Pesticides
- relevant sector standards e.g. EU Council Directive 91/271/EEC Concerning Urban Waste Water Treatment
- grievance redress mechanism including types of grievances to be recorded and how to protect confidentiality e.g. of those reporting allegations of GBV/SEA
- GBV/SEA prevention and management

7.3 MINIMUM REQUIREMENTS FOR THE BIDDER'S CODE OF CONDUCT

The Bidder shall submit the Code of Conduct that will apply to the Contractor's employees and subcontractors.

A minimum requirement for the Code of Conduct should be set out by the Employer, taking into consideration the issues, impacts, and mitigation measures identified, for example, in :

- project reports e.g. ESIA/ESMP
- any particular GBV/SEA requirements
- consent/permit conditions (regulatory authority conditions attached to any permits or approvals for the project)
- required standards including World Bank Group EHS Guidelines
- relevant international conventions, standards or treaties, etc., national legal and/or regulatory requirements and standards (where these represent higher standards than the WBG EHS Guidelines)
- relevant standards e.g. Workers' Accommodation: Process and Standards (IFC and EBRD)
- relevant sector standards e.g. workers accommodation
- grievance redress mechanisms.

The types of issues identified could include. risks associated with: labor influx, spread of communicable diseases, sexual harassment, gender based violence, illicit behavior and crime, and maintaining a safe environment etc.

A satisfactory code of conduct will contain obligations on all Contractor's personnel (including subcontractors and day workers) that are suitable to address the following issues, as a minimum. Additional obligations may be added to respond to particular concerns of the region, the location and the project sector or to specific project requirements. The code of conduct shall contain a statement that the term "child" / "children" means any person(s) under the age of 18 years.

The issues to be addressed include:

- Compliance with applicable laws, rules, and regulations

- Compliance with applicable health and safety requirements to protect the local community (including vulnerable and disadvantaged groups), the Employerø and Project Managerø personnel, and the Contractorø personnel, including sub-contractors and day workers, (including wearing prescribed personal protective equipment, preventing avoidable accidents and a duty to report conditions or practices that pose a safety hazard or threaten the environment)
- The use of illegal substances
- Non-Discrimination in dealing with the local community (including vulnerable and disadvantaged groups), the Employerø and Project Managerø personnel, and the Contractorø personnel, including sub-contractors and day workers (for example on the basis of family status, ethnicity, race, gender, religion, language, marital status, age, disability (physical and mental), sexual orientation, gender identity, political conviction or social, civic, or health status)
- Interactions with the local community(ies), members of the local community (ies), and any affected person(s) (for example to convey an attitude of respect, including to their culture and traditions)
- Sexual harassment (for example to prohibit use of language or behavior, in particular towards women and/or children, that is inappropriate, harassing, abusive, sexually provocative, demeaning or culturally inappropriate)
- Violence including sexual and/or gender based violence (for example acts that inflict physical, mental or sexual harm or suffering, threats of such acts, coercion, and deprivation of liberty)
- Exploitation including sexual exploitation and abuse (for example the prohibition of the exchange of money, employment, goods, or services for sex, including sexual favors or other forms of humiliating, degrading behavior, exploitative behavior or abuse of power)
- Protection of children (including prohibitions against sexual activity or abuse, or otherwise unacceptable behavior towards children, limiting interactions with children, and ensuring their safety in project areas)
- Sanitation requirements (for example, to ensure workers use specified sanitary facilities provided by their employer and not open areas)
- Avoidance of conflicts of interest (such that benefits, contracts, or employment, or any sort of preferential treatment or favors, are not provided to any person with whom there is a financial, family, or personal connection)
- Respecting reasonable work instructions (including regarding environmental and social norms)
- Protection and proper use of property (for example, to prohibit theft, carelessness or waste)
- Duty to report violations of this Code
- Non retaliation against workers who report violations of the Code, if that report is made in good faith.

The Code of Conduct should be written in plain language and signed by each worker to indicate that they have:

- received a copy of the code;
- had the code explained to them;
- acknowledged that adherence to this Code of Conduct is a condition of employment; and
- understood that violations of the Code can result in serious consequences, up to and including dismissal, or referral to legal authorities.

A copy of the code shall be displayed in a location easily accessible to the community and project affected people. It shall be provided in languages comprehensible to the local community, Contractor's personnel (including sub-contractors and day workers), Employer's and Project Manager's personnel, and affected persons.

APPENDIX 1: BORROW AREAS MANAGEMENT PLAN

Embankment fill material is to be procured from borrow areas designated for the purpose. The properties of the borrow material shall be got tested and recorded. Borrow area management plan pertains to the measures that need to be incorporated during identification of borrow area location, material extraction and rehabilitation.

If required, borrow areas will be identified by the Contractor and after identification site specific details (including revenue record, rehabilitation plan and agreement with owner) will be submitted to CSC for approval. Once approved, Contractor would require operating and closing the site as per EMP reporting formats.

The contractor in addition to the established practices, rules and regulation will also consider following criteria before finalizing the locations. During design stage of the project, following borrow areas have been identified.

- i) The borrow area should not be in agriculture field unless unavoidable i.e. barren land is not available.
- ii) The borrow pits should not be located along the roads.
- iii) The loss of productive and agriculture soil should be minimum.
- iv) The loss of vegetation is almost nil or minimum.
- v) Sufficient quality of soil is available.
- vi) The Contractor will ensure that suitable earth is available.

The Contractor shall obtain representative samples from each of the identified borrow areas and have these tested at the site laboratory following a testing programme approved by the CSC.

Though, reuse of excavated material will be done for filling up of embankments or other such requirements, but in case of lack of suitable material following locations have been identified, which can be used as borrow areas by contractor after taking approval from owner and other authorities as required.

Identified borrow areas along the Project Road

BA. No.	Existing Chainage (km)	Lead (m)	Side (LHS/RHS)	Ownership Details
BA-1	10+500	20	LHS	Government

No borrow area shall be operated without permission of the Engineer. The procurement of borrow material should be in conformity to the guidelines laid down in IRC:10-1961. In addition, the contractor should adopt the following precautionary measures to minimize any adverse impacts on the environment:

- I. The unpaved surfaces used for haulage of borrow materials will be maintained dust free by the contractor through sprinkling of water twice a day during the period of use.
- II. To avoid any embankment slippage, the borrow areas will not be dug continuously, and the size and shape of borrow pits will be decided by the Engineer.
- III. Borrow pits situated less than 0.8 km (if unavoidable) from villages and settlements should not be dug for more than 30 cm after removing 15cm of topsoil and should be drained.

- IV. The Contractor shall maintain erosion and drainage control in the vicinity of all borrow pits and make sure that surface drains do not affect the adjacent land or future reclamation. This needs to be rechecked by the engineer of the PIU.
- V. In case the borrow pit is on agricultural land, the depth of borrow pits shall not exceed 45 cm and may be dug out to a depth of not more than 30 cm after stripping the 15 cm top soil aside.
- VI. To prevent damages to adjacent properties, the Contractor shall ensure that an undisturbed buffer zone exists between the distributed borrow areas and adjacent land. Buffer zone shall be 3 m wide or equal to the depth of excavation whichever is greater.
- VII. In case of riverside or near any stream, borrow pit should be located not less than 15m from the toe of the bank, distance depending on the magnitude and duration of flood to be withstood.
- VIII. In no case shall be borrow pit be within 1.5m from the Toe line of the proposed embankment.

Borrow Areas located in Agricultural land, where un-avoidable

- I. The preservation of topsoil will be carried out in stockpile.
- II. A 15 cm topsoil will be stripped off from the borrow pit and this will be stored in stockpiles in a designated area for height not exceeding 2m and side slopes not steeper than 1:2 (Vertical: Horizontal).
- III. The depth of borrow pits will not be more than 30 cm after stripping the 15 cm topsoil aside.

Borrow Areas located in Elevated Lands

- I. The preservation of topsoil will be carried out in stockpile.
- II. A 15 cm topsoil will be stripped off from the borrow pit and this will be stored in stockpiles in a designated area for height not exceeding 2m and side slopes not steeper than 1:2 (Vertical: Horizontal).
- III. At location where private owners desire their fields to be leveled, the borrowing shall be done to a depth of not more than 1.5m or up to the level of surrounding fields

Borrow Areas near River side

- I. The preservation of topsoil will be carried out in stockpile.
- II. A 15 cm topsoil will be stripped off from the borrow pit and this will be stored in stockpiles in a designated area for height not exceeding 2m and side slopes not steeper than 1:2 (Vertical: Horizontal).
- III. Borrow area near to any surface water body will be at least at a distance of 15m from the toe of the bank or high flood level, whichever is maximum.

Borrow Areas near Settlements

- I. The preservation of topsoil will be carried out in stockpile.
- II. A 15 cm topsoil will be stripped off from the borrow pit and this will be stored in stockpiles in a designated area for height not exceeding 2m and side slopes not steeper than 1:2 (Vertical: Horizontal).

- III. Borrow pit location will be located at least 0.75 km from villages and settlements. If un-avoidable, the pit will not be dug for more than 30 cm and drains will be cut to facilitate drainage.
- IV. Borrow pits located in such location will be re-developed immediately after borrowing is completed. If spoils are dumped, that will be covered with a layer of stockpiled topsoil in accordance with compliance requirements with respect MOEF/HPCB guidelines.

Borrow Pits along the Road

- I. The preservation of topsoil will be carried out in stockpile.
- II. A 15 cm topsoil will be stripped off from the borrow pit and this will be stored in stockpiles in a designated area for height not exceeding 2m and side slopes not steeper than 1:2 (Vertical: Horizontal).
- III. Borrow pits along the road shall be discouraged.
- IV. If permitted by the Engineer; these shall not be dug continuously.
- V. Ridges of not less than 8m widths should be left at intervals not exceeding 300m.
- VI. Small drains shall be cut through the ridges to facilitate drainage.
- VII. The depth of the pits shall be so regulated that their bottom does not cut an imaginary line having a slope of 1 vertical to 4 horizontals projected from the edge of the final section of bank, the maximum depth of any case being limited to 1.5m.
- VIII. Also, no pit shall be dug within the offset width from the toe of the embankment required as per the consideration of stability with a minimum width of 10m.

Once used, all borrow areas would require rehabilitation as follows.

Re-development of Borrow Areas

The objective of the rehabilitation Programme is to return the borrow pit sites to a safe and secure area, which the general public should be able to safely enter and enjoy. Securing borrow pits in a stable condition is fundamental requirement of the rehabilitation process. This could be achieved by filling the borrow pit floor to approximately the access road level.

Re-development plan will be prepared by the Contractor before the start of work in line with the owners will require and to the satisfaction of owner.

The Borrow Areas will be rehabilitated as per following;

Depending on the choice of the individual land owner/community, the contractor shall prepare redevelopment plans for the borrow areas. The options can be: (i) Restoring the productive use of the land (ii) Development of detention ponds in barren areas;

Option I: Suitable in locations with high rainfall and productive areas;

- Topsoil must be placed, seeded, and mulched within 30 days of final grading if it is within a current growing season or within 30 days of the start of the next growing season.
- Vegetative material used in reclamation must consist of grasses, legumes, herbaceous, or woody plants or a combination thereof, useful to the community for the fuel and fodder needs.

- Plants must be planted during the first growing season following the reclamation phase.
- Selection and use of vegetative cover must take into account soil and site characteristics such as drainage, pH, nutrient availability, and climate to ensure permanent growth.
- The vegetative cover is acceptable if within one growing season of seeding, the planting of trees and shrubs results in a permanent stand, or regeneration and succession rate, sufficient to assure a 75% survival rate.

Option II: In barren land, the borrow areas can be redeveloped into detention ponds. These will be doubled up as water bodies and also for removal of sediment from runoff flowing through the ponds. Design of the detention basin depends upon the particle size, settling characteristics, residence time and land area. A minimum of 0.02 mm size particle with a settling velocity of 0.02 cm/sec (assuming specific gravity of solids 2.65) can be settled in the detention basin.

- Pond should be located at the lowest point in the catchment area. Care should be taken that the horizontal velocity should be less than settling velocity to prevent suspension or erosion of deposited materials.
- Minimum Effective Flow Path: 5 times the effective width
- Minimum Free Board: 0.15 m
- Minimum Free Settling Depth: 0.5 m
- Minimum Sediments Storage Depth: 0.5 m
- Maximum interior slope: 2H : 1V
- Maximum exterior slope: 3H : 1V
- The inlet structure should be such that incoming flow should distribute across the width of the pond.
- A pre-treatment sump with a screen should provide to remove coarse sediments.
- Settled sediment should be removed after each storm event or when the sediment capacity has exceeded 33% of design sediment storage volume.
- Accumulated sediment must be disposed of in a manner, which will prevent its re-entry into the site drainage system, or into any watercourse.

Note;

The Contractor will keep record of photographs of various stages i.e., before using materials from the location (pre-project), for the period borrowing activities (construction Phase) and after rehabilitation (post development), to ascertain the pre and post borrowing status of the area.

APPENDIX 2: QUARRY MATERIALS

The Contractor will finalize the locations in consultation with CSC and CMU as per HP Mineral Policy 2013. The Contractor shall establish a new quarry only with the prior consent of the CSC only in cases when: (i) Lead from existing quarries is uneconomical and (ii) Alternative material sources are not available. The Contractor shall prepare a Redevelopment Plan for the quarry site and get it approved by the CSC.

The construction schedule and operations plan to be submitted to the CSC prior to commencement of work shall contain a detailed work plan for procuring materials that includes procurement, transportation and storage of quarry materials.

Operation & redevelopment plan (if a new quarry is opened):

- Photograph of the quarry site prior to commencement
- The quarry boundaries as well as location of the materials deposits, working equipment, stockpiling, access roads and final shape of the pit.
- Drainage and erosion control measures at site.
- Safety Measures during quarry operation.
- Design for redevelopment of exhaust site.

Option-A: Re vegetating the quarry to merge with surrounding landscape: This is done by conserving and reapplying the topsoil for the vegetative growth.

Option-B: Developing exhausted quarries as water bodies: The pit shall be reshaped and developed into pond, for harvesting rainwater. This option shall only be considered where the location of quarry is at the lowest point, i.e. surrounding areas/natural drainage slopes towards it.

CONSTRUCTION STAGE

Development of site: To minimize the adverse impact during excavation of material following measures need to be undertaken:

1. Adequate drainage system shall be provided to prevent the flooding of the excavated area
2. At the stockpiling locations, the Contractor shall construct sediment barriers to prevent the erosion of excavated material due to runoff
3. Construction of offices, laboratory, workshop and rest places shall be done in the up wind of the plant to minimize the adverse impact due to dust and noise.
4. The access road to the plant shall be constructed taking into consideration location of units and also slope of the ground to regulate the vehicle movement within the plant.

Quarry operations including safety

1. Overburden shall be removed and disposed in line with Guidelines of Debris Disposal Management.
2. During excavation, slopes shall be flatter than 20 degrees to prevent their sliding. In cases where quarry strata are good and where chances of sliding are less this restriction can be ignored.

3. The Contractor shall ensure that all workers related health and safety measures shall be done as per guidelines given in appendix 12.
4. The Contractor shall ensure maintenance of crushers regularly as per manufacturer's recommendation.

Topsoil will be excavated and preserved during transportation of the material measures shall be taken to minimize the generation of dust and prevent accidents.

The CMU and the CSC shall review the quarry site for the management measures during quarry operation, including the compliance to pollution norms.

POST CONSTRUCTION STAGE

The Contractor shall restore all haul roads constructed for transporting the material from the quarries to construction site to their original state.

The CMU and the CSC shall be entrusted the responsibility of reviewing the quarry site for the progress of implementation of Redevelopment Plan. These shall include the following two cases;

- Redevelopment of quarries opened by the Contractor for the project
- Redevelopment of existing quarries operated by other agencies

In the first case, the Contractor shall be responsible for the Redevelopment Plan prior to completion after five years, during the defect liability period. The CSC and CMU shall be responsible for reviewing this case of redevelopment prior to the issuing the defect liability certificate.

In the second case, the redevelopment of exhaust quarry shall be the responsibility of the agency providing the permit to ensure the implementation of Redevelopment Plan.

APPENDIX 3: GENERAL GUIDELINES FOR CONTRACTOR'S CONSTRUCTION WATER MANAGEMENT PLAN

During Construction, except bituminous works, water is required during all stages of road construction such as Embankment Sub-Grade; Granular sub-base (GSB) and Water Bound Macadam (WBM). Water will also be required for other purposes (drinking, cooking, washing etc). These water requirements will be met from available sources along road or by bore wells etc.

The estimated water requirements are 162 lakh liters during project period for civil works like embankment, sub-grades, bituminous work, concrete, dust suppression and daily consumptive use at work force camp, site offices, among others. The breakup of water requirement for different usage during the project cycle is given below is given below.

Estimated Construction Water Requirement for the project

S.No.	Activity	Unit	Quantity in litres/m	MDR-26
1	Road/Embankment	Litres/metre	500	70
2	Subgrade/WBM	Litres/metre	250	35
3	Construction of CD Structures	Ls@10000 litres per location	-	6
4	Dust Suppression and camp site management	Litres/metre	250	35
5	On site sanitation & Drinking water	per day	5000	8
6	Camp Site Water Requirement	Litres	1000	2
7	Plantation of saplings/trees	Litres	5400000	60
Total Water Requirement				216
Add 5% for wastage and 20% for Contingency				270
Quantity of Water Requirement for entire Construction period				485
Quantity of Water Requirement KLD				162

Contractor will be required to calculate daily water requirements and identify the sources that can meet the requirements. Contractor for the purpose would require preparing a Water Management plan. The plan will consist of identified locations (annexed Appendix 15), timings to fetch water from these locations and all required permission from the authorities for approval to CSC.

During construction, the Contractor shall be responsible to monitor the following:

The arrangements worked out with the PRI/individual land owners for water extraction is adhered to;

- Extraction of water is restricted to construction requirement and domestic use of construction workers.
- Water requirement for curing of concrete shall be minimized by pooling of water over the concrete or by covering with wet gunny bags.
- Water used for mixing of mortar/concrete and subsequent curing is free from injurious amount of oil, acids, alkalis, salts, sugar, organic materials or other substances that may be deleterious to concrete

or steel and this water should conform to Clause 1010 of MoRT&H 'Specifications for Road and Bridge works - Fourth Revision' and IS: 456, and,

- The potable water used for drinking purposes of construction workers shall be as per the Indian Standard for Drinking Water IS: 10500, 1991.

Do's and Don'ts for The Contractor

There are several dos and Don'ts for construction water usage for the Contractor as provided below;

- Contractor's vehicles shall not be allowed to wash in the river or stream. This is to avoid potential pollution from pol residues.
- Contractors shall not use water from the community drinking water sources such as;
 - Public water supply schemes
 - Community spring water sources
 - Community hand pumps
 - Community bore wells /shallow tube wells
 - any water harvesting structures of community or Govt
 - Location of or the streams from which the community take drinking water
- Contractor shall obtain all legal approvals and clearances from the concerned departments
- Contractor shall consult the local communities where the water source has been identified
- Various water sources available along the roadside are provided in appendix-15 (Layout maps of seasonal and permanent water sources) and to fetch water from these or such other sources a prior approval from competent authority e.g. Irrigation and Public Health department, HP must be taken.

Post Construction Stage

Once the Contractor finishes its job, water source can be handed over to the local Panchayat or for local communities.

The two possible alternate uses of this structure would be;

- Local communities of this area can use the same to meet their water needs.
- This could be a water hole for the wildlife (if any) in that area.

Prior to issuing project completion certificate to the contractor, the CSC shall verify that the premises of water extraction points are restored to their original status after construction.

APPENDIX 4: SELECTION AND MANAGEMENT OF CONSTRUCTION CAMP

Contractor would require plan for siting, development, management and restoration of construction camps to avoid or mitigate impacts on the environment. The area requirement for the construction camp shall depend upon the size of contract, number of laborers employed and the extent of machinery deployed. The key activities requiring addressal during the project stages are as follows.

Stages	Key Activities
Pre-construction	Siting
	Development
Construction	Maintenance
Post-Construction	Restoration

Pre-construction stage

- The Contractor shall identify the site for construction camp in consultation with the individual owners in case of private lands and the Gram Panchayat in case of Government lands. The suitable sites shall be selected and finalized in consultation with the CSC.
- The contractor will work out arrangements for setting up his facilities during the duration of construction with the land owner/Gram Panchayat. The arrangements will include the restoration of the site after the completion of construction. The arrangements will be verified by the CSC/PIU to enable redressal of grievances at a later stage of the project

Selection of construction camp/site locations	
<p>Avoid the following ...</p> <ul style="list-style-type: none"> • Lands close to habitations • Irrigated agricultural lands • Lands belonging to small farmers • Lands under village forests • Lands within 100m of community water bodies and water sources as rivers • Lands within 100m of watercourses • Low lying lands • Lands supporting dense vegetation • Grazing lands and lands with tenure rights • Lands where there is no willingness of the landowner to permit its use 	<p>Prefer the following ...</p> <ul style="list-style-type: none"> • Waste lands • Lands belonging to owners who look upon the temporary use as a source of income • Community lands or government land not used for beneficial purposes • Private non-irrigated lands where the owner is willing and • Lands with an existing access road

After finalization of the site, the contractor shall submit to the CSC a detailed layout plan for development of the construction camp, indicating the various structures to be constructed including the temporary structures to be put up, drainage and other facilities. The plan will include the redevelopment of sites to pre-construction stage.

Arrangements with landowners...
<p>The contractor shall submit to CSC the following:</p> <ul style="list-style-type: none"> • Written No-objection certificate of the owner/cultivator • Extent of land required and duration of the agreement

- | |
|--|
| <ul style="list-style-type: none"> • Photograph of the site in original condition • Details of site redevelopment after completion |
|--|

Accommodation: The contractor shall provide, free of cost in the camp site, temporary living accommodation to all the workers employed by him for such a period as the construction/maintenance work is in progress.

Towards the provision and storage of drinking water at the construction camp, the contractor shall ensure the following provisions;

- The contractor shall provide for a sufficient supply of potable water in the construction camps, in earthen pots or any other suitable containers. The contractor shall identify suitable community water sources as handpumps and ponds for procuring drinking water, in consultation with the Gram Panchayat.
- Only in the event of non-availability of other sources of potable water, the Contractor shall obtain water from an unprotected source, after the testing for its potability. Where water has to be drawn from an existing open well, the well shall be properly chlorinated before water is drawn from it for drinking. All such wells shall be entirely closed in and be provided with dust proof trap door.
- Every water supply or storage shall be at a distance of not less than 15m from any wastewater / sewage drain or other source of pollution. Water sources within 15m proximity of toilet, drain or any source of pollution will not be used as a source of drinking water in the project.
- A pump shall be fitted to each covered well, the trap door shall be kept locked and opened only for cleaning or inspection, which shall be done at least once a month

In every site, adequate and suitable facilities for washing clothes and utensils shall be provided and maintained for the use of contract labor employed therein. Separate and adequate bathing facilities shall be provided for the use of male and female workers. Such facilities shall be conveniently accessible and shall be kept in clean and hygienic conditions.

Sanitary arrangements, latrines and urinals shall be provided in every work place on the following scale:

- Where female workers are employed, there shall be at least one latrine for every 25 females or part thereof.
- Where males are employed, there shall be at least one latrine for every 25 males or part thereof.
- Every latrine shall be under cover and so partitioned off as to secure privacy, and shall have a proper door and fastenings.
- Where workers of both sexes are employed, there shall be displayed outside each block of latrine and urinal, a notice in the language understood by the majority of the workers "For Men Only" or "For Women Only" as the case may be.
- The latrines and urinals shall be adequately lighted and shall be maintained in a clean sanitary condition at all times and
- Water shall be provided in or near the latrines and urinals by storage in suitable containers.

Arrangements for Waste Disposal;

- Disposal of sanitary wastes and excreta shall be into septic tanks.

- Kitchen wastes shall be disposed into soak pits. Wastewater from campsites will be discharged and disposed in a kitchen sump located preferably at least 15 meters from any body of water. Sump capacity should be at least 1.3 times the maximum volume of wastewater discharged per day. The bottom of the pit should be filled with coarse gravel and the sides shored up with board, etc. to prevent erosion and collapse of the pit.
- Solid wastes generated in the construction site shall be reused if recyclable or disposed of in land fill sites

First Aid Facilities;

- First Aid Box will be provided at every construction campsite and under the charge of a responsible person who shall always be readily available during working hours of the work place. He shall be adequately trained in administering first aid-treatment. Formal arrangement shall be prescribed to carry injured person or person suddenly taken ill to the nearest hospital.

Storage Site;

- Storage of Petrol/Oil/Lubricants: Brick on edge flooring or sand flooring will be provided at the storage places of Petrol/Oil/Lubricants to avoid soil and water contamination due to spillage.
- Storage of cement: Damp-proof flooring, as per IS codes

Firefighting arrangement;

- Demarcation of area susceptible to fires with cautionary signage,
- Portable fire extinguishers and/or sand baskets shall be provided at easily accessible locations in the event of fire,
- Contractor shall educate the workers on usage of these equipment

Interactions with host communities;

- To ensure that there is no conflict of the migrant labor with the host communities, the contractor shall issue identity cards to labourers and residents of construction camps.

Construction Stage:

Construction camps shall be maintained free from litter and in hygienic condition. It should be kept free from spillage of oil, grease or bitumen. Any spillage should be cleaned immediately to avoid pollution of soil, water stored or adjacent water bodies. Following precautions need to be taken in construction camps.

- Measures to ensure that no leaching of oil and grease into water bodies or underground water takes place
- Wastewater should not be disposed into water bodies
- Regular collection of solid wastes should be undertaken and should be disposed of safely
- All consumables as the first aid equipment, cleaning equipment for maintaining hygiene and sanitation should be recouped immediately

CSC will monitor the cleanliness of construction campsites and ensure that the sites are properly maintained throughout the period of the contract.

Post Construction Stage:

At the completion of construction, all construction camp facilities shall be dismantled and removed from the site. The site shall be restored to a condition in no way inferior to the condition prior to commencement of the works. Various activities to be carried out for site restoration are:

- Oil and fuel contaminated soil shall be removed and transported and buried in waste disposal areas.
- On the construction camp site, saplings of species similar to that of cut trees shall be planted.
- Saplings planted shall be handed over to the community or the land owner for further maintenance and watering
- Soak pits and septic tanks shall be covered and effectively sealed off

APPENDIX 5: DEBRIS DISPOSAL SITE MANAGEMENT

The excess debris will be required to dispose of at pre identified debris disposal locations. If not disposed of carefully, the erosion could take these loose materials in to nullahs and then further to the major River basin. Hence the Contractor needs to plan for the disposal of debris in such a way, so that it may not harm or create any hindrance for the implementation of the project. The dumping areas shall be arranged by the contractor at his own cost.

A poor management may lead to very poor engineering practices, community conflicts and the stoppage of the works etc. and that would incur huge losses to all concerned. The possible impacts due to poor management are described below;

- **Obstruction to natural watercourse**

The materials if not disposed of properly would be taken by the running water to the lowest portion of the valleys creating huge obstruction to free flow of natural stream water. If people are residing nearby that would affect their life by way of flooding or by spoiling the premises.

- **Siltation in surface water reservoirs**

Most of the materials would be ultimately taken down stream through rivers and ultimately depositing into reservoirs leading to heavy siltation. This in turn would reduce the reservoir capacity substantially within a very short span. This could incur huge losses to the exchequer. De-siltation is also expensive and normally carried out after many years of operation of reservoirs in the natural circumstances.

- **Soil erosion**

Massive soil erosion is the most direct impact of the debris excavation. The precipitation and the consequent run off would erode the loose materials by way of suspension and solution. Once reached up to the mainstream courses, even the big boulders would be transported down due to the steep gradients available along the stream courses.

- **Flash floods**

Debris spilled over valley or nallah sometimes can be fatal, if there are houses or roads downstream. Houses and roads (having vehicles) can be flooded away.

- **Spoiling of agricultural land**

As a usual practice mainly due to poor planning and limited resources, the Contractor usually throws the materials to the nearby valley areas. This would be taken down to the private agricultural areas. The farmer will incur huge losses and may even sue the Contractor. As a result, the project could be stopped indefinitely leading to losses for the people of the State.

During the execution phase, Contractor should plan for its safe disposal according to the geographical status of area. For this Contractor will be required to prepare a Debris disposal management plan.

- The contractor shall identify the activities during construction, that have the potential to generate waste and work out measures for the same in the construction schedule to be submitted to the CSC. For the disposal of excess cut and unsuitable (non-toxic) materials, the contractor shall identify the location for disposal in consultation with the community / Gram Panchayat. Any toxic materials shall be disposed in existing landfill sites that comply with legislative requirements. Prior to disposal of wastes onto private/community land, it shall be the responsibility of the Contractor to obtain a No-objection Certificate (NOC) from the land owner/community.

- The Contractor shall educate his workforce on issues related to disposal of waste, the location of disposal site as well as the specific requirement for the management of these sites

The locations of Disposal sites have to be selected such that:

- No residential areas are located downwind side of these locations,
- Disposal sites shall be located at least 1000 m away from sensitive locations like Settlements, Water body notified forest areas, Sanctuaries or any other sensitive Locations.
- Disposal sites do not contaminate any water sources, rivers etc. for this site should be located away from water body, and Disposal site should be lined properly to prevent infiltration of water.
- Public perception about the location of debris disposal site has to be obtained before finalizing the location.
- The Plan must be approved by Environment Specialist of Supervision Consultant.

Contractor needs to plan the disposal in the following way

- Identify the disposal area.
- Estimate the disposal quantities.
- Consult with all stake holders and prepare an agreement with landowner.
- Prepare a suitable design for the safe disposal
- Design should have provision of protection (gabion etc.) at the base, grass or shrubs plantation on the naked slope.
- Need to photograph the present land use and condition of the area.
- Submit the copy of agreement, design, photographs, and estimate along with revenue records (Jamabandi, Tatima and Musabbietc) to the supervision consultant.
- After getting the plan approved, dispose of the debris in the identified location only.
- Construct all required protection structures prior to disposal (e.g. retaining wall).
 - Compact of the materials after disposal.

Rehabilitation procedures

After completion, the debris disposal sites filled only up to the ground level could be rehabilitated as per guidelines below and to be decided by the supervision consultant.

- The debris disposal sites have to be suitably rehabilitated by planting local species of shrubs and other plants. Local species of trees has also to be planted so that the landscape is coherent and is in harmony with its various components (bioengineering methods).
- In cases where a debris disposal sites is near to the local village community settlements; it could be converted into a play field by spreading the disposed debris evenly on the ground. Such playground could be made coherent with the landscape by planting trees all along the periphery of the playground.
- Some of the debris disposal sites could be used either for plantation or for growing agricultural produce such as ginger, turmeric or oranges etc.
- Care should always be taken to maintain the hydrological flow in the area.

In case of disposal of wastes on private land, certificate of Completion of Reclamation is to be obtained by the Contractor from the landowner that the land is restored to his satisfaction

S.No.	Location	Type of Land	Site Conditions and Potential Impacts	Capacity (m ³)	Mitigation Measures	Remarks
				Area (Ha)		
1	7+900 (LHS)	Govt/ PWD Land	The site is in old alignment of the road very next to the ROW, in PWD land. The site have 3 trees and they can be restored after filling.	4,000m ³ (L=100m; W=8m; H=5m)	Provision of gabion wall to avoid it getting eroded during rainy season with rainwater and to support the disposed debris. The boundary of the gabion wall needs to be follow the stream border.	It may gave extra space to widening the road and visibility to the other side vehicles since the alignment is passing through the settlements.
				0.08 ha		
2	8+900 (LHS)	Govt/ PWD Land	The site is near to habitation. It's a barren land (valley)	3,600m ³ (L=80m; W=9m; H=5m)	A consultation with the local people needs to be carried prior to using the site and any operation will be done based on outcome of the consultation.	It might helps to the local people to park own vehicles.
			Dust and noise pollution during disposal of material.	0.072 ha	Trees replantation should be taken in priority stages.	
3	10+420 (LHS)	Govt/ PWD Land	The site is a barren land next to the habitation and having some trees.	12,000m ³ (L=150m; W=8m; H=10m)	Provision of gravity wall to support debris, and to avoid erosion. Provision of bioengineering measures to stabilise slope.	It help to provide parking space to the road users. And the access to the drinking water structure next to this location.
				0.12 ha		
4	11+000 (LHS)	Govt/ PWD Land	The site us barren land located next to the khud and having shrubs and trees.	20,000 m ³ (L=200m; W=10m; H=10m)	Dump can be done in two layers with two levels, while dumping and provide gravity/gabion walls to avoid erosion to the khud.	It helps in better visibility of bridge and vehicles coming on the it to the vehicular user.
				0.20 ha		

Contractor will also approach district administration for the identification of suitable debris disposable sites/land for debris, as per Construction and demolition waste management rules, 2016.

APPENDIX-6: TRAFFIC AND SAFETY MANAGEMENT DURING CONSTRUCTION

The safety and health concerns of the workers and the public are impacted due to the hazards created during the construction of road. Contractor is required to prepare a plan for the effective implementation of the traffic safety and safety arrangements along the construction zones. Traffic control refers to the use of temporary traffic control devices to protect workers and to move road users safely through a work zone. A traffic management plan is usually required to outline the traffic hazards, and to specify the measures needed for traffic control. Health and safety legislation focus on safety requirements including increased visibility of the workers, signage, and signaling.

Concerns on Safety:

General Public due to.....	Workers due to.....
<ul style="list-style-type: none"> • Improper scheduling of construction activities especially near the settlements • Parking of equipment and vehicles at the end of the day is likely to cause accidents to the public especially during night hours. • Transportation of uncovered loose material or spillage of material increases the chances of accidents to road users and surrounding settlements. 	<ul style="list-style-type: none"> • Improper handling of materials like bitumen, oil and other flammable material at construction sites, likely to cause safety concerns to the workers. • Lack of safety measures such as alarm, awareness and safety equipment result in accidents, especially working with or around heavy machinery / equipment.

Management during Construction

Contractor shall not open numerous construction fronts simultaneously. The number of opening fronts should depend on the capability and capacity of the Contractor to effectively manage the work sites with his dedicated staff. Prior to opening of new work fronts, after the completion of the work, the area should be safely closed in all respects with suitable information or sign boards.

Contractor will provide:

- Protective footwear, protective goggles and nose masks to the workers employed in asphalt works, concrete works, crusher etc.
- Welder’s protective eye-shields to workers who are engaged in welding works
- Earplugs to workers exposed to loud noise, and workers working in crushing or compaction
- The Contractor will comply with all regulations regarding safe scaffolding, ladders, working platforms, gangway, stairwells, excavations, trenches and safe means of entry and egress.
- The Contractor will comply with all the precautions as required for ensuring the safety of the workmen as per the International Labour Organization (ILO).
- The Contractor will make sure that during the construction work all relevant provisions of Building and other Construction Workers (regulation of Employment and Conditions of Services) Act, 1996 are adhered to.

- The Contractor will not employ any person below the age of 14 years for any work and no woman will be employed on the work of painting with products containing lead in any form.
- The Contractor will also ensure that no paint containing lead or lead products is used except in the form of paste or readymade paint.
- Contractor will provide facemasks for use to the workers when paint is applied in the form of spray or a surface having lead paint dry is rubbed and CSC rapped.
- The Contractor will mark -hard hatø and -no smokingø and other -high riskø areas and enforce non-compliance of use of PPE with zero tolerance. These will be reflected in the Construction Safety Plan to be prepared by the Contractor during mobilization and will be approved by CSC and CMU.
- To promote and encourage a Safety culture, senior most engineers in Contractors team and in the CSCø teams shall wear helmets and safety jackets.

List of Personal Protective Equipment

S. No	Part of the Body	Personal Protective Equipment	S. No	Part of the Body	Personal Protective Equipment
1	Eye	Safety Glasses, Goggles	5	Feet	Safety Shoes
2	Face	Face Shields	6	Hands and arms	Gloves
3	Nose	Nose Masks	7	Bodies	Vests
4	Head	Helmets	8	Hearing	Earplugs, Earmuffs

The Contractor will take all necessary measures for the safety of traffic during construction and provide, erect and maintain barricades, including signs, markings, flags, lights and flagmen as proposed in the Traffic Control Plan/Drawings and as required by the Environmental Expert of CSC for the information and protection of traffic approaching or passing through the sections of any existing cross roads.

The Contractor will ensure that all signs, barricades, pavement markings are provided as per the MoRTH specifications. Before taking up of construction on any section of the existing lanes of the highway, a Traffic Management Plan will be devised and implemented to the satisfaction of the Environmental Specialist of CSC.

List of Traffic Safety Equipment

S. No	Signs	S. No	Signs
1	Barricading	6	Flagmen
2	Men at Work	7	Narrow Signs
3	Keep Left	8	Lantern (Amber Blinker)
5	Go Slow	9	Traffic Control Lights

Additional provisions need to be undertaken for safety at site;

- Adequate lighting arrangements.
- Adequate drainage system to avoid any stagnation of water.
- Lined surface with slope 1:40 (V:H) and provision of lined pit at the bottom, at the storage and handling area of bitumen and oil, as well as at the location of generator (grease trap).

- Facilities for administering first aid.

First Aid Kit, distinctly marked with Red Cross on white background and shall contain minimum of following:

- 6 small-sterilized dressings
- 3 medium and large sterilized dressings
- 1 bottle (30 ml.) containing 2 % alcoholic solution of iodine
- 1 bottle (30 ml) containing Sal volatile
- 1 snakebite lancet
- 1 pair sterilized scissors
- 100 tablets of aspirin
- Ointment for burns
- A suitable surgical antiseptic solution

Adequate arrangement shall be made for immediate recoupment of the equipment, whenever necessary.

Trained personnel in charge of first aid treatment to be readily available during working hours at construction site.

Suitable transport to the nearest approachable hospital should be made available.

The following measures need to be adopted by the Contractor to address public safety concerns:

The Contractor shall schedule the construction activities taking into consideration factors such as:

- Frequent movement of the people during sowing and harvesting of crops, local festivals etc.
- Settlement areas;
- Locations having sensitive receptors; Traffic and safety management on these locations needs additional planning because of the frequent movement of students and patients.

Note:

- Safety Jackets and helmets should be provided to all the workers/engineers working on the road.
- Fixed mobile solid barricades must be placed between the workmen and traffic or pedestrian and traffic.
- All the elements of Work zone Safety arrangements and signage shall be confirming to IRC: 67 and IRC: SP: 55: 2014.
- Site specific traffic management plan for all types of works shall be prepared and shall be submitted along with daily work zone safety check list to be signed by each party to the Project Manager/CSC for approval prior to Starting of any activity.
- Starting of any activity without submission and approval of the above will be treated as fundamental breach of contract.

A typical diagram showing traffic management during construction phase is given below for reference.

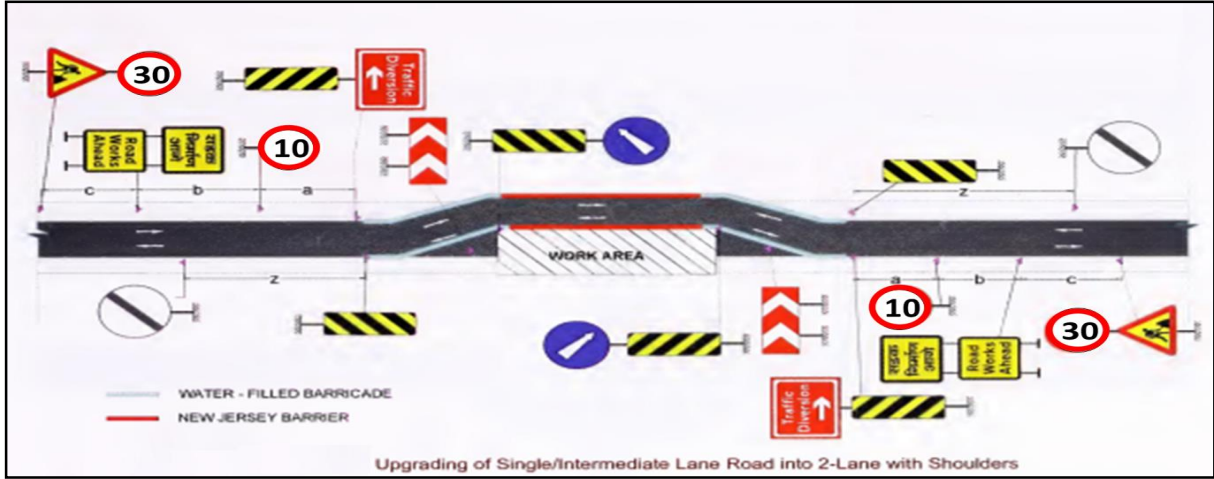

APPENDIX 7: FORMATS FOR ENVIRONMENTAL REPORTING

RF 1: CONSTRUCTION CAMP/ PLANT SITE MANAGEMENT PLAN

S.NO	Description	Compliance
1	Name of the location	
2	Nearest road chainage.	
3	Name of the owner	
4	Area involved	
5	Arrangements with the owner (agreement with landowner, including the restoration aspects, should be attached as an Annexure)	
6	Existing land use	
7	Photographs depicting the present condition of the construction camp and access road.	
8	Land use of the area surrounding the borrow area including a map	
9	Site layout plan of the construction camp	
10	Establishment and maintenance of demarcated and labelled different areas within the camp	
11	Number of trees to be removed, if any, along with compensation measures	
12	Proposed topsoil management	
13	Activities planned in the construction camp	
14	Machinery & equipment to be used on site	
15	Labour camp facilities onsite	
16	Health facilities	
17	Site drainage provisions	
18	Copy of the consents to establish and operate should be attached as an Annexure	
19	Conditions laid down in the clearance / licenses and plans	
20	Staff strength and details such as contractor staff vs sub contractors, women labour, migrant vs local labour and skilled & unskilled labour	
21	Access road condition and proposed maintenance	
22	Safety provision such as fire protection equipment and personal protective measure.	
23	Closure / completion plan	Format RF: 1A

RF 1A: CLOSURE PLAN CONSTRUCTION CAMP AND/ PLANT SITE

S. No	Description	Compliance
1	Name / identity of location	
2	Distance from the Project Road and side	
3	Name of the owner	
4	Details of the Land i). Survey Number ii). Boundaries iii). Other Revenue Details	
5	Details of settlements, sensitive areas, water bodies, wells and bore wells within 500 m Population in Numbers Name of the Village Distance from the construction camp Details of water bodies/ sensitive areas/ wells/ bore wells	
6	Physical Details Number of Labour Stationed Number of Dwellings Constructed Number of toilets provided Were dwellings demolished Were the wastewater treatment facilities demolished and cleared? Was the solid waste generated cleared and disposed of properly, if yes specify the location and quantity? Whether any soil was contaminated with oils and waste oils was cleared and disposed safely, if yes specify the location and quantity. Was scrap generated while the construction removed, if yes specify the details such as where, when, to whom and quantity.	
7	Land Use before Establishment Proposed Use after completion of works	

F 2: BORROW AREA NO

S. No	Description	Compliance
1	Name / identity of location	
2	Nearest project road chainage	
3	Name of the owner	
4	Area involved/capacity/quantity	
5	Type of material proposed to be taken	
6	Arrangement with the owner including restoration aspect.	
7	Existing land use	
8	Land use of the area surrounding the proposed area	
9	A map of the area	
10	Number of trees to be removed, if any along with the compensation measure	
11	Topsoil management if required	
12	Access road condition and proposed maintenance	
13	Photograph depicting the present condition of the proposed area and access road	

14	Closure / completion plan	Format RF 2A
----	---------------------------	---------------------

RF 2A: CLOSURE PLAN FOR BORROW AREA

S. No	Description	Compliance
1	Name / identity of location	
2	Nearest Project chainage, distance from the Project Road and side	
3	Name of the owner	
4	Details of the Land i. Survey Number ii. Boundaries iii. Other Revenue Details	
5	Details of settlements, sensitive areas, water bodies within 500 m Population in Number Name of the Village Distance from the borrow area. Details of water bodies/ sensitive areas/ wells/ bore wells	
6	Physical Details Length and width in meters Depth excavated in meters Quantity Excavated in cum Type of materials excavated	
7	Land Use before Opening Proposed Use before opening Details of surroundings	
8	Drawing showing the dimensions of the borrow areas, access roads and features of surrounding	
9	Number of trees removed(girth>300mm), if any along with the compensation measure	
10	Details of topsoil Quantity excavated in cum Where was it used	
11	Initial access road condition and final access road condition	
12	Photographs depicting the original condition, during the operation, topsoil management, and after closure	
13	Copy of the agreement with the Owner Details of the agreed redevelopment if any	
14	Land use after rehabilitation Details should be submitted if the final land use changed from the original land use	
15	Satisfaction certificate from the owner	
16	Details of the practical problems faced, and solutions adopted, if any during the operation phase	

RF3: CONSTRUCTION CAMP / PLANT AND ENVIRONMENTAL MANAGEMENT

S. No	Issue	Status
		Camp-1
1	Drainage System 1. Closed drainage	
2	Disposal for Wastewater 1. Kitchen wastewater 2. Wastewater from water closets 3. Wastewater from bathrooms	

	4. Wastewater from the vehicular washings.	
3	Collection and Disposal of Solid Waste 1. Waste from the office 2. Waste from the kitchen 3. Waste from sweeping	
4	Drinking Water facility Source with quantity No of bore wells with capacity Location of the well and bore well Any treatment facility No of overheads tanks Test results of the Drinking water Any license obtained	
5	First Aid Facility	
6	Roads in Camp Site Type of road Dust suppression practicing or not, if the roads are not tarred. Condition of the road.	
7	Fuel Storage 1. Impervious Base 2. Spills and Wastewater will be collected in a sump 3. Number of drums where wastes are collected. 4. Number of drums disposed	
8	Garbage & Night Soil 1. Provision of Garbage Bins 2. Separation of Polythene materials 3. Records of solid waste removal from septic tanks	

RF 4: TOPSOIL MANAGEMENT

S. No.	Chainage in km	Quantity in cum	Whether Preserved in accordance with specifications	Remarks
1				
2				
3				
4				
5				
6				
7				
8				

RF 5: CONSTRUCTION PLANTS AND POLLUTION CONTROL

S. No.	Construction Plant	Locations	Capacity	Description of Pollution Control System/ Equipment	Remarks
1					
2					
3					
4					
5					
6					
7					

RF 6: MACHINERY/ VEHICLES AND POLLUTION CONTROL

S. No	Machinery / vehicles with capacity	Diesel consumed during the month	Engine oil consumed during the month	PUC certificate no./validity	Machinery new/ old	Remarks
1						
2						
3						
4						

RF 7: DETAILS OF THE DG SETS WITH THE POLLUTION CONTROL EQUIPMENT

S. No	Capacity in KVA	Vertical Stack If provided height in m	Noise Control System	Remarks
Camp-1				
Camp -II				
Crusher -I				
Plant Site -I				
Construction Works				

RF 8: DETAILS OF OIL STORAGE

S. No	Type of Product	Location	Number of Barrels	Capacity of barrels in Litres	Increase/ Decrease in Storage	Stored on Impervious base (Yes/No)	Remarks
1	Diesel						
2	Petrol						
3	Engine Oils						
4	Lubricants						

RF 9: WORKING AT WATER COURSE AND POLLUTION CONTROL MEASURES

S. No	Location	Type	Stream/ Canal Diversion	Silt Fencing	Remarks

RF 10: DETAILS OF THE GROUND WATER EXTRACTION

S. No	Location	Capacity of Motor Installed in HP	Quantity of water drawn in Kilo litres			Ground water department Permission	Type of source
			During the month	Up to end of last month	Total		

RF 11: PERSONAL PROTECTIVE EQUIPMENT

S. No	Details of Equipment	Total Procured in No	Distributed in No	Available in Store in No	Remarks
1	Helmets				
2	Safety Shoes				
3	Safety Shoes				
4	Nose Masks				
5	Hand Gloves				
6	Goggles				
7	Safety Belts				
8	Ear Plugs				
9	Reflective Jackets				
10	Gum Boots				

RF 12: STATUS OF CONSENTS FOR WATER EXTRACTION

Plant	Consent	Number / Status	Validity Date	Remarks

RF 13: DEVIATIONS WITH CORRECTIVE ACTIONS

S.No	Deviation	Corrective Actions	Schedule

**RF 14: IMPLEMENTATION OF ENHANCEMENT MEASURES FOR CULTURAL PROPERTIES,
WATER HARVESTING STRUCTURES**

S. No	Type of Enhancement	Side of the Road (R/L)	Progress of Completion		Reasons of delay if any
			Target date	Actual Completion date	

RF 15: IDENTIFICATION OF DISPOSAL SITE LOCATIONS

(To be filled by the Contractor)

Name of Corridor _____

Link No. _____

(Give chainages and nearest settlements from both ends)

S. No	Criteria on which information for each site is to be collected	Site 1	Site 2	Site 3	Site 4
1	Existing Land Use				
2	Area covered (m2)				
3	Total Material that can be dumped within the site (m3)				
4	Depth to which dumping is feasible (m)				
5	Distance of nearest watercourse (m)				
6	Nearest Settlement (m)				
7	Date/s of Community Consultation/s				
8	Whether the community is agreeable to siting of dumping site (Y/N)				
9	Date of Permission from Villager/local community				
10	Proposed future use of the Site				
11	Selected Site (tick any one column only)				

Enclosures (Tick as appropriate)

Map of each location

Photographs

Each Disposal location

Each community consultation

Photocopy of Agreement (along with revenue record of the owner)

Remark

Submitted

Signature í í í í í í

Name í í í í í í í .

Designation í í í í ..

Contractor

Checked

Signature í í í í í í í ..

Name í í í í í í í í

Environmental Engineer.

Construction Supervision Consultant

Approved

Signature í í í í í í í

Name í í í í í í í í ..

Executive Engineer PWD

RF 16: FORMATS FOR GRIEVANCE REDRESSAL MECHANISM DURING CONSTRUCTION

A		PROJECT DETAILS				INFORMATION		
1	Name of the Project							
2	Name and address of the Contractor							
3	Contract Date and Duration							
B		Details of Complaints Received			Site Name			
Sl. No	Date of Complaint	Name and Address of Person with Contact Details	Complaint	Action Taken with Date	Signature of Environmental representative of Contractor			
1								
2								
3								
4								

A Register in this format shall be maintained at each site office of the contractor. This same format shall be used to compile and report the details of received at all sites to complaints received at all sites to the CSC along with the monthly Report of the contractor. The Environmental Engineer of CSC has to give instructions to the contractor, if any further action has to be taken on any complaint

RF 17: REPORTING FORMAT FOR WORK FORCE MANAGEMENT

A		PROJECT DETAILS			DATE OF REPORTING	
1	Name of the package and Corridor					
2	Name and Address of the contractor					
3	Contract date and duration					
4	Name of Work Site with Sl. No. in register of site					
B		Status of work force				
S. No	Category of work force	Work force in the Previous Month (No)	Work Force added in the reporting month (No.)	Work Force left in the reporting month (No.)	Total Work Force in the reporting month (No.)	
1	Unskilled Labourers					
2	Skilled labourers					
3	Supervisors					

4	Engineers				
5	Office Staff				
6	Sub Total				
7	Grand Total				

C. Categorization of Work Force

S. No	Category of work Force	Male		Female		Employment Status		Residential Status		Accommodation Status	
		< 18 years	< 18 years	< 18 years	< 18 years	Regular	Temporary	Migrant	Local	Staying in Labour Camp/Quarters	Others
1	Unskilled Labourers										
2	Skilled labourers										
3	Supervisors										
4	Engineers										
5	Office Staff										
	Sub Total										
	Grand Total										

D. Details of the non-working migrated people, living in the labour camps/Staff Quarters as part of work force family

No. of Children (0-6 yrs)	No. of Children (7-18 yrs)	No of Adults	Grand Total
----------------------------------	-----------------------------------	---------------------	--------------------

E. Submission Details

	Submitted by (Environmental Officer of the Contractor)	Approved By (Environmental Engineer of CSC)
Signature & Date		
Name		
Designation		
Remarks by CSC		

Note:

Contractor must fill and submit this format to the CSC along with the Monthly Report. In addition to that, the contractor must maintain the database of work force in the form of a register. An attendance register for the work force should also be maintained by the Contractor. Contractor must report the details of migrant work force to the nearest Police station. The CSC must visit the site and verify the details. The Environmental Engineer of CSC must give back a copy of this format to the contractor after his approval with remarks.

RF-18: REPORTING FORMAT FOR OCCUPATIONAL HEALTH AND SAFETY MEASURES

A	Project Details	Date of reporting:	
1	Name of the package and Corridor:		
2	Name and Address of the contractor:		
3	Contract date and duration:		
4	Status of completion of the project:		
B	Implementation Status of Health and Safety Measures		
S. No	Health and Safety Measures	Implementation Status(Yes/No)	Remarks
1	Appointment of qualified Environment and Safety Engineer		
2	Approval for Construction Safety Management Plan by the Engineer		
3	Provision for flags and warning lights for potential hazards		
4	Provision of adequate staging, from work and access (ladders and handrail) for works at a height of more than 3.0m		
5	Provision of adequate Shorting/bracing/barricading/lighting for all deep excavations of more than 3.0m depth		
6	Provision for enough lighting especially for night-time work		
7	Construction Workers Safety-Provision of personnel protective equipment		
	A. Helmets		
	B. Safety Shoes		
	C. Dust Masks		
	D. Hand Gloves		
	E. Safety Belts		
	F. Reflective Jackets		
	G. Ear Plugs for Labour		
8	Workers engaged in welding works shall be provided with welder protective shields		
9	All vehicles are provided with reverse horns		
10	All Scaffolds, ladders and other safety devices shall be maintained in as safe and sound condition		
11	Ensuring the sanitary conditions and all waste disposal procedures & methods in the camp		
12	Ensuring the sanitary conditions and all waste disposal procedures & methods in the camps.		
13	Provisions for insurance coverage to the workers		
C	Submission Details		

	Submitted by (Environmental representative of the Contractor)	Approved By (Environmental Specialist of CSC)	
Signature & Date			
Name			
Designation			
Remarks by CSC:			

Note:

Contractor must fill and submit these formats to the CSC along with the Monthly Report. The CSC must visit the site and verify the details. Further mitigation measures, if required, can be suggested by the CSC. The Environmental Engineer of CSC must give back a copy of this format to the contractor after his approval with remarks.

RF 19: FOR ROAD SAFETY MEASURES DURING CONSTRUCTION

A	Project Details	Date of Reporting:	
	Name of Package and Corridor		
	Name and address of the		
	Contract date and duration		
	Status of completion of the project		
B	Details of Safety Measures		
S. No	Safety Measures	Compliance Status (Yes/no)	Remarks
a	General		
1	A qualified Environment and Safety Engineer should be appointed		
2	A Traffic Management Plan should be prepared in accordance with IRC: SP: 55- 2001 and got approved by the Engineer		
3	Maintenance of existing road stretches handed over to the Contractor should be carried out		
b	Details of Construction Zone		
1	Length of transition sub zone should be min 50 m for a speed of 50km/hr		
2	Length of work sub zone in urban stretch should be <2 km		
3	Length of work sub zone in rural stretch should be 5-10 km		
c	Signage's in construction zones		
1	Sign saying 'Men at Work' should be kept 1 km ahead of Transition sub zone		
2	Supplementary sign saying Diversion 1km should be provided		
3	Sign saying 'Road Closed ahead' should be provided		
4	Compulsory Turn Right/Left sign should be provided		
5	Detour sign should be placed		
6	Sharp Deviation sign should be placed at end of advance warning sub zone		
7	Signage should be provided in Transition Sub Work Zone		
8	Signage saying 'Keep Right/Left' should be provided		
9	Signage should be placed in work sub zone		
10	Hazard Marker should be placed where railing for CD structure on diversion starts		
11	Barricade should be provided on either side of work sub zone		
12	Flags and warning lights should be provided at Construction zones		
13	Flag persons should be provided for traffic control		

14	Metal drum /empty bitumen drum delineator, painted in circumferential strips of alternate black and white 100mm wide 2 coats fitted with reflectors 3 Nos of 7.5cm diameter or Barricades/caution tapes should be provided in construction zones		
15	Plastic crash barriers should be provided		
16	Demarcations (fencing, guarding and watching) should be provided at bridge / culvert construction sites		
17	Arrangements should be made for controlled access and entry to Construction zones		
18	Regular Inspection of Work Zone Traffic Control Devices should be carried out by authorized contractor personnel		
19	All vehicles should be provided with reverse horns		
20	Speed of construction vehicles should be controlled through road safety training of drivers		
d	Signage in Termination sub zone		
1	Sign for indication of end of work zone should be placed 120m from end of termination sub zone		
e	Road Delineators		
1	Roadway indicators should be provided		
2	Hazard markers should be provided		
3	Object markers should be provided		
f	Submission Details		
	Submitted by (Environment & Safety Engineer of Contractor)	Approved by (Environmental Engineer of CSC)	
	Signature& date		
	Name		
	Designation		

Note: Contractor must fill this format and submit to the

CSC along with the Monthly Report. The CSC must visit the sites and verify the details.

Additional safety

measures, if required, can be suggested by

the CSC. The Environmental Engineer of CSC must give back a copy of this

format

to the contractor after his approval with remarks.

RF 20: FORMAT FOR REGISTERING OF ACCIDENTS AND ITS REPORTING

A	Project Details	Date of Reporting
1	Name of package and Corridor	
2	Name and address of the contractor	
3	Contract date and duration	
4	Status of completion of the Project	
B	Details of Accident and People Involved in Accident	
	Name of site where accident happened	
	Name and address of people involved in the accident	
	Whether Contractor's personal or General public	
	Details of Injury	
	Details of compensation given	
C	Type of Accident (√)	
	Fall of person from a height	Explosion
	Slip,trip or fall on same level	Fire
	Struck against fixed objects	Contract with hot or corrosive substance
	Struck by flying or falling objects	Contract with poisonous gas or toxic substances.
	Struck be moving objects	Contract with poisonous gas or toxic substances.
	Struck/caught by cable	Hand tool accident
	Stepping on hall etc.	Vehicle/Mobile plant accident
	Handling without machinery	Machinery operation accident
	Crushing/burying	Other (please specify)
	Drowning or asphyxiation	
D	Agent Involved in Accident (√)	
	Machinery	Stair edge
	portable power appliance	Excavation/underground working
	Vehicle or associated equipment / machinery	Ladder
	Material being handled, used or stored	Scaffolding/gondola
	Gas, vapour, dust, fume or oxygen	Construction formwork, shuttering and false work
	Hand tools	Electricity supply cable, wiring switchboard and associated equipment
	Floor edge	Nail, splinter or chipping
	Floor opening	Other (please specify)
	Left shaft	
E	Unsafe Action Relevant to the Accident (√)	
	Operating without authority	Failure to use proper footwear

	Failure to secure objects		Failure to use eye protector
	Making safety devices inoperative		Failure to use respirator
	Working on moving or dangerous equipment		Failure to use proper clothing
	Using un-safety equipment		Failure to use warn others or given proper signals
	Adopting unsafe position or posture		Horseplay
	Operating or working at unsafe speed		No unsafe action
	Unsafe loading, Placing, mixing et		Other (please specify)
	Failure to use helmet		
F	Lack of Safety Measures Relevant to the Accident (√)		
	No protective gear		Unsafe layout of job, traffic etc.
	Defective protective gear		Unsafe process of Job methods
	Improper dress/footwear		Poor housekeeping
	Improper guarding		Lack of warning system
	Improve ventilation		Defective tool, machinery or material
	Improper illumination		No unsafe condition
	Improper procedure		Other (please specify)
G	Personal Factor Relevant to the Accident (√)		
	Incorrect attitude/motive		No unsafe personal factor
	Unsafe act by another person		Other (please specify)
H	Details of Corrective and Prevention action taken		
1			
2			
3			
I	Submission details		
	Submitted by (Environment & Safety Engineer of Contractor)		Approved by (Environment Specialist of CSC)
	Signature & Date		
	Name		
	Designation		
	Remarks by CSC		

RF 21: REPORTING FORMAT FOR MONTHLY REPORT FROM CONTRACTOR TO CSC

A Project Details		Information							
1	Name of Package and Corridor								
2	Name and address of the Contractor								
3	Contract date and duration								
B Physical Progress Report									
S. No	Enhancement Measures	Physical Target (Nos)	Units carried over from previous month	Units started in reporting months	Units completed in reporting months	Unit carried over to next month	Cumulative units completed till end of reporting month	% target completed	Remarks/Reasons for delay
		(a)	(b)	(c)	(d=a+b+c)				
1	Noise Barrier								
2	Hand Pumps								
3	Bus Shelter								
4	Sign Board								
5	Preserving and land scaping cultural properties								
6	Constructing new Well								
7	Providing new water taps								
8	Planting trees along roadside								
9	Planting trees on inner side of sound insulating wall								
C Details of Sites for Project Ancillary Facility									
1	Construction Camp								
2	Labour Camp								
3	Quarry & Stone Crusher Unit								
4	Borrow Area								
5	Debris disposal sites								

6	Water							
<i>A site will be considered closed after redeveloping and obtaining closure certificate from CSC</i>								
D	Summary of Machinery and equipment available							
S. No	Type of equipment/machinery/vehicles		Nos. Available	Validity date of PUC certificate (as applicable)	Remarks			
1								
2								
E								
S.No.	Details of Notices issued by CSC	Date of Issue	Type of Lapse (Major/Minor)	Notice no	Corrective action taken	Remarks		
<i>* In case of minor lapse, specify whether original notice, first reminder or second reminder.</i>								
F	Reporting Format	Yes/No	S. No	Reporting Format	Yes/No			
1	Format for Register of sites opened and closed and its reporting		8	Reporting Format for Register of Accident and its reporting				
2	Format for Register of complaints and its reporting		9	Reporting Format for Enhancement Measures of Cultural Properties				
3	Reporting Format for Work Force Management		10	Reporting Format for Noise Barrier Construction				
4	Reporting Format for Occupational Health and Safety Measures		11	Reporting Format for Enhancement Measures Other than Cultural Properties				
5	Reporting Format for Topsoil Conservation		12	Reporting Format for Tree Plantation				
6	Reporting Format for Water Sprinkling for Dust Suppression		13	Reporting Format for Environmental Quality Monitoring				
7	Reporting Format for Road Safety Measures During Construction							
G	Submission Details							
		Submitted by (Environment & Safety Engineer of Contractor)			Approved by (Environment Specialist of CSC)			
Signature & Date								
Name								
Designation								
Remarks by CSC								

APPENDIX 8: NATIONAL STANDARDS OF AIR, NOISE, WATER AND SOIL

National Ambient Air Quality Standards

Pollutant	Time Weighted Average	Concentration in Ambient Air		Methods of Measurement
		Industrial, Residential, Rural and other Areas	Ecologically Sensitive Area	
Sulphur Dioxide (SO ₂), µg/m ³	Annual * 24 Hours **	50 80	20 80	-Improved West and Gaeke Method -Ultraviolet Fluorescence
Nitrogen dioxide (NO ₂), µg/m ³	Annual * 24 Hours **	40 80	30 80	-Jacob & Hochheiser modified (NaOH-NaAsO ₂) Method -Gas Phase Chemiluminescence
Particulate Matter (Size less than 10µm) or PM ₁₀ , µg/m ³	Annual * 24 Hours **	60 100	60 100	-Gravimetric -TEOM -Beta attenuation
Particulate Matter (Size less than 2.5µm) or PM _{2.5} , µg/m ³	Annual * 24 Hours **	40 60	40 60	-Gravimetric -TEOM -Beta attenuation
Ozone (O ₃), µg/m ³	8 Hours * 1 Hour **	100 180	100 180	-UV Photometric -Chemiluminescence -Chemical Method
Lead (Pb), µg/m ³	Annual * 24 Hours **	0.50 1.0	0.50 1.0	-AAS/ICP Method after sampling on EPM 2000 or equivalent filter paper -ED-XRF using Teflon filter
Carbon Monoxide (CO), mg/m ³	8 Hours ** 1 Hour **	02 04	02 04	-Non dispersive Infrared (NDIR) Spectroscopy
Ammonia (NH ₃), µg/m ³	Annual * 24 Hours **	100 400	100 400	-Chemiluminescence -Indophenol blue method
Benzene (C ₆ H ₆), µg/m ³	Annual *	05	05	-Gas Chromatography (GC) based continuous analyzer -Adsorption and desorption followed by GC analysis
Benzo(a)Pyrene (BaP) Particulate phase only, ng/m ³	Annual *	01	01	-Solvent extraction followed by HPLC/GC analysis
Arsenic (As), ng/m ³	Annual *	06	06	-AAS/ICP Method after sampling on EPM 2000 or equivalent filter paper
Nickel (Ni), ng/m ³	Annual *	20	20	-AAS/ICP Method after sampling on EPM 2000 or equivalent filter paper

Water Quality Standards

S. No	Parameters	IS:2296 (Class C)	IS:10500	Method Adopted
1	PH	6.5-8.5	6.5-8.5	pH meter
2	BOD (3 days 27°C)	3.0	NS	DO-Azide modification of Winkler's method
3	Temperature (C)	NS	NS	Thermometer
4	Dissolved oxygen	4	NS	Azide Modification of Winkler's method
5	Color (Hazen)	300	NS	Visual Comparison method
6	Fluorides (F)	1.5	1.0(1.5)	SPANDS method
7	Chlorides (Cl)	600	250(1000)	Argentometric Titration
8	Total Dissolved Solids	1500	500 (2000)	Gravimetric Analysis
9	Sulphates (SO ₄)	400	200 (400)	Barium Chloride method
10	Iron (Fe)	50	0.3(1.0)	Phenanthroline method
11	Oil and Grease	0.1	NS	Partition - Gravimetric method
12	Nitrates	50	45 (100)	Chromotropic acid
13	Chromium (Cr ⁶⁺)	0.05	0.05	Atomic Absorption Spectrophotometry
14	Cadmium (Cd)	0.01	0.01	Atomic Absorption Spectrophotometry
15	Lead(Pb)	0.1	0.05	Atomic Absorption Spectrophotometry
16	Copper (Cu)	1.5	0.05 (1.5)	Atomic Absorption Spectrophotometry
17	Cyanide (CN)	0.05	0.05	Chloramine-T-method
18	Selenium (Se)	0.05	0.01	Atomic Absorption Spectrophotometry
19	Arsenic (As)	0.2	0.05	Atomic Absorption Spectrophotometry
20	Phenols	0.005	0.001(0.002)	Spectrophotometer
21	Detergents	1.0	0.2(1.0)	Spectrophotometer
22	DDT	Absent	Absent	Spectrophotometer
23	Total Coliform (MPN/100 ml)	5000	NS	Multiple Tube Fermentation Technique

National Ambient Noise Standards

Area Code	Category of Zones	Limits of Leq in dB(A) Day*	Night*
A	Industrial	75	70
B	Commercial	65	55
C	Residential	55	45
D	Silence Zone **	50	40

Daytime shall mean from 6.00am to 10.00 pm and Night shall mean from 10.00 pm to 6.00 am Silence zone is defined as area up to 100 meters around premises of hospitals, educational institutions and courts.

Use of vehicles horns, loudspeakers and bursting of cracking are banned in these zones.

APPENDIX 9: ENVIRONMENT FRIENDLY CONSTRUCTION METHODOLOGY

The contractor shall be deemed to have acquainted himself with the requirements of all the current statutes, ordinances, by-laws, rules and regulations or their instruments having the force of law including without limitation those relating to protection of the environment, health and safety, importation of labour, demolition of houses, protection of environment and procurement, transportation, storage and use of explosives, etc.

1 Protection of Environment

- a) The contractor will take all necessary measures and precautions and ensure that the execution of the works and all associated operations on site or offsite are carried out in conformity with statutory and regulatory environmental requirements including those prescribed in EMP.
- b) The contractor will take all measures and precautions to avoid any nuisance or disturbance to inhabitants arising from the execution of works.
- c) All liquid waste products arising on the sites will be collected and disposed of at a location on or off the sites and in a manner that will not cause either nuisance or pollution.
- d) The contractor will always ensure that all existing water courses and drains within and adjacent to the site are kept safe and free from any contamination.
- e) The contractor will submit details of his temporary drainage work system (including all surface channels, washing basins and discharge pits) to the CSC and CMU for approval prior to commencing work on its construction.
- f) The contractor will arrange all the equipment in good condition to minimize dust, and other air-borne emissions and carry out the works in such a manner as to minimize adverse impact on air.
- g) Any vehicle with an open load-carrying area used for transporting potentially dust-producing material will have properly fitted side and tailboards. Materials having the potential to produce dust will not be loaded to a level higher than the side and tail boards and will be covered with a clean tarpaulin in good condition.
- h) The contractor will take all necessary measures to ensure that the operation of all mechanical equipment and condition processes on and off the site will not cause any unnecessary or excessive noise, considering applicable environmental requirements.
- i) The contractor will take necessary measures to maintain all plant and equipment in good condition.
- j) Where the execution of the works requires temporary closure of road to traffic, the contractor will provide and maintain temporary traffic diversions subject to the approval of the CSC.
- k) Where the execution of the works requires single-lane operation on public road the contractor will provide and maintain all necessary barriers, warning signs and traffic control signals to the satisfaction of the CSC.
- l) Wherever traffic diversions, warning signs, traffic control signals, barriers and the like are required, the contractor will install them to the satisfaction of CSC prior to commencing the work, in that area.
- m) Contractor will install asphalt plants and other machineries away from the populated areas as per laid down regulations.

- n) Permit for felling of trees will be obtained from the forest department before the execution of any work.
- o) Water sprinkling should be provided at appropriate places for preventing dust pollution during handling and stockpiling of stones and loose earth.
- p) Over Burden (OB) waste dumps shall be sprayed with water, as they are the major source of air borne particulate matter.
- q) OB waste dumps shall be reclaimed / afforested to bind the loose soil and to prevent soil erosion. The frequency of sprinkling should be fixed as per the seasonal requirement and in consultation with engineer.
- r) Regular water spraying on haulage roads during transportation of construction material by water sprinklers. The frequency of sprinkling should be fixed as per the seasonal requirements in consultation with engineer.
- s) Transfer point for transporting construction material shall be provided with appropriate hoods/ chutes to prevent dust emissions.
- t) Dumping of construction material should be from an optimum height (preferably not too high), so as to reduce the dust blow.
- u) Innovative approaches of using improvised machinery designs, with in-built mechanism to reduce sound emission.
- v) Procurement of drill loaders, dumpers and other equipment with noise proof system in operator's cabin.
- w) Confining the equipment with heavy noise emissions in soundproof cabins, so that noise is not transmitted to other areas.
- x) Regular and proper maintenance of noise generating machinery including the transport vehicles to maintain noise levels.
- y) Provisions should be made for noise absorbing pads at foundations of vibrating equipment to reduce noise emissions.

2 Quarry Operations

The Contractor shall obtain materials from quarries only after the consent of the Forest Department or other concerned authorities and in consultation with the Engineer. The quarry operations shall be undertaken within the purview of the rules and regulations in force.

3 Prevention of Water Courses from Soil Erosion

The Contractor shall apply following mitigation measures to prevent sedimentation and pollution of watercourses.

- To prevent increased siltation, if need be existing bridges maybe widened downstream side of the water body;
- Cement should be stacked fenced by bricks or earth wall, and kept away from water, to prevent leachate formation and contamination of surface and ground water;

- If need be, slope of the embankments leading to water bodies should be modified and rechanneled to prevent entry of contaminants into the water body;

4 Pollution from hot-mix plants and batching plants

Bituminous hot-mix plants and concrete batching plants shall be located sufficiently away from habitation, agricultural operations. The Contractor shall take every precaution to reduce the levels of noise, vibration, dust and emissions from his plants and shall be fully responsible for any claims for damages caused to the owners of property, fields and residents in the vicinity.

5 Arrangement for traffic during construction

The Contractor shall always carry out work on the road in a manner creating least interference to the flow of traffic with the satisfactory execution. For all works involving improvements to the existing state highway, the Contractor shall, in accordance with the directives of the CSC, provide and maintain, during execution of the work, a passage for traffic either along a part of the existing carriageway under improvement, or along a temporary diversion constructed close to the state highway. The Contractor shall take prior approval of the CSC regarding traffic arrangements during construction.

6 Traffic safety and control

- a) Where subject to the approval of the Engineer the execution of the works requires temporary closure of road to traffic use, the Contractor shall provide and maintain temporary traffic diversions. The diversion shall generally consist of 200 mm thickness of gravel 4.5 meters wide laid directly upon natural ground and where any additional earthworks are required for this purpose that will be provided under the appropriate payment items.
- b) Where the execution of the works requires single-lane operation on public road, the Contractor shall provide and maintain all necessary barriers, warning signs and traffic control signals to the approval of the Engineer.
- c) Except for temporary traffic arrangements or diversions required within the first 4 weeks of the Contract, the Contractor shall submit details of his proposals to the Engineer for approval not less than 4 weeks prior to the temporary arrangement or diversion being required. Details of temporary arrangements or diversions for approval as soon as possible after the date of the Letter of Acceptance.
- d) The color, configuration, size and location of all traffic signs shall be in accordance with the code of practice for road sign. In the absence of any detail or for any missing details, the signs shall be provided as directed by the Engineer (CSC).
- e) The Contractor shall take all necessary measures for the safety of traffic during construction and provide, erect and maintain such barricades, including signs, marking, flags, lights and flagmen as may be required by the Engineer for the information and protection of traffic approaching or passing through the section of the road under improvement. Before taking up any construction, an agreed phased Programme for the diversion of traffic or closer of traffic on the road shall be drawn up in consultation with the SE.
- f) At the points where traffic is to deviate from its normal path (whether on temporary diversion or part width of the carriageway) the lane width path for traffic shall be clearly marked with the aid of pavement markings, painted drums or a similar device to the directions of the SE. At night, the passage shall be delineated with lanterns or other suitable light source.
- g) One-way traffic operation shall be established whenever the traffic is to be passed over part of the carriageway inadequate for two-lane traffic. This shall be done with the help of temporary traffic

signals or flagmen kept positioned on opposite sides during all hours. For regulation of traffic, the flagmen shall be equipped with red and green flags and lanterns / lights.

- h) On both sides, suitable regulatory / warnings signs as approved by the SE shall be installed for the guidance of road users. On each approach, at least two signs shall be put up, one close to the point where transition of carriageway begins and the other 120 m away. The signs shall be of design and of reflector type, if so, directed by the SE.
- i) Upon completion of the works for which the temporary traffic arrangements or diversions have been made, the Contractor shall remove all temporary installations and signs and reinstate all affected roads and other structures or installations to the conditions that existed before the work started, as directed by the Engineer.

7 Health and safety

The contractor shall take all measures and precautions necessary to ensure the health, safety and welfare of all persons entitled to be on the site. Such precautions shall include those that, in the opinion of the Engineer, are reasonable to prevent unauthorized entry upon the site and to protect members of the public from any activities under the control of the contractor. The contractor's responsibilities shall include but not be limited to:

- a) The provision and maintenance of the Contractor's Equipment in a safe working condition and the adoption of methods of work that are safe and without risks to the health of any person entitled to be on the site.
- b) The execution of suitable arrangements for ensuring safety and absence of risks to health in connection with the use, handling, storage, transport and disposal of articles and substances,
- c) The provision of lighting, including standby facilities in the event of failure that, in the opinion of the Engineer, is adequate to ensure the safe execution of any works that are to be carried out at night.
- d) The provision of protective clothing and safety equipment, with such personnel and equipment and such information, instruction, training and supervision as are necessary to ensure the health and safety at work of all persons employed on or entering on the site in connection with the works, including the Engineer's supervisory staff, all in accordance with the laws.
- e) Near towns, villages and all frequented places, trenches and foundation pits shall be securely fenced provided with proper caution signs and marked with lights at night to avoid accidents. Contractor shall take adequate protective measures to see that the excavation operations do not affect or damage adjoining structures.
- f) The contractor shall not use or generate any materials in the works, which are hazardous to the health of persons, animals or vegetation. Where it is necessary to use some substances, which can cause injury to the health of workers, the Contractor shall provide protective clothing or appliances to his workers.
- g) The contractor will take all measures necessary to safeguard the health; safety and welfare of all persons entitled to be on site and will ensure that works are carried out in a safe and efficient manner.
- h) The contractor will provide and ensure the utilization of appropriate safety equipment for all workmen and staff employed directly or indirectly by the contractor. Such safety equipment will include but not be limited to the safety helmets, goggles and other eye protectors, hearing protectors, safety harnesses, safety equipment for working over water, rescue equipment, fire extinguishers and first-aid equipment. The personnel working at vulnerable locations at site will wear safety helmets and strong footwear.

- i) The contractor will provide an adequate number of latrines and other sanitary arrangements at areas of the site where work is in progress and ensure that they are regularly cleaned and maintained in a hygienic condition.

8 First aid

- i) The provision and maintenance of suitably equipped and staffed first aid stations throughout the extent of the works to the satisfaction of the Engineer. The contractor shall allow in his prices and the responsible for the costs of all such site welfare arrangements and requirements.
- ii) Injuries might occur during the construction period. It is therefore pertinent to provide first aid facilities for all the construction workers. At construction camps and at all workplaces first aid equipment and nursing staff must be provided. Since many of the workplaces may be far away from regular hospitals, an indoor health unit having one bed facility every 250 workers needs to be provided.
- iii) Adequate transport facilities for moving the injured persons to the nearest hospital must also be provided in ready to move condition.
- iv) The first-aid units apart from an adequate supply of sterilized dressing material should contain other necessary appliances as per the factory rules.

9 Maintenance

- i) All buildings, rooms and equipment and the grounds surrounding them shall be maintained in a clean and operable condition and be protected from rubbish accumulation.
- ii) Each structure made available for occupancy shall be of sound construction, shall assure adequate protection against weather, and shall include essential facilities to permit maintenance in a clean and operable condition. Comfort and safety of occupants shall be provided for by adequate heating, lighting, ventilation or insulation when necessary to reduce excessive heat.

10 Maintenance of diversions and traffic control devices

Signs, lights, barriers and other traffic control devices, as well as the riding surface of diversion shall be maintained in a satisfactory condition till such time they are required as directed by the SE. The temporary traveled way shall be kept free of dust by frequent applications of water, if necessary.

APPENDIX 10: SOIL EROSION AND SEDIMENTATION CONTROL

All materials shall meet commercial grade standards and shall be approved by the Engineer before being used in the work.

Construction operations

Prior to the start of the relevant construction, the Contractor shall submit to the CSC for approval, his schedules for carrying out temporary and permanent erosion/sedimentation control works as are applicable for the items of clearing and grubbing, roadway and drainage excavation, embankment/sub-grade construction, bridges and other structures across water courses, pavement courses and shoulders. He shall also submit for approval his proposed method of erosion/sedimentation control on service road and borrow pits and his plan for disposal of waste materials. Work shall not be started until the erosion/sedimentation control schedules and methods of operations for the applicable construction have been approved by the Engineer.

The surface area of erodible earth material exposed by clearing and grubbing, excavation, borrow and fill operations shall be limited to the extent practicable. The Contractor may be directed to provide immediate control measures to prevent soil erosion and sedimentation that will adversely affect construction operations,

damage adjacent properties, or cause contamination of nearby streams or other watercourses. Such work may involve the construction of temporary berms, dikes, sediment basins, slope drains and use of temporary mulches, fabrics, mats, seeding, or other control devices or methods as necessary to control erosion and sedimentation.

The Contractor shall be required to incorporate all permanent erosion and sedimentation control features into the project at the earliest practicable time as outlined in his accepted schedule to minimize the need for temporary erosion and sedimentation control measures.

Temporary erosion/sedimentation and pollution control measures will be used to control the phenomenon of erosion, sedimentation and pollution that may develop during normal construction practices but may neither be foreseen during design stage nor associated with permanent control features on the Project.

Where erosion or sedimentation is likely to be a problem, clearing and grubbing operations should be so scheduled and performed that grading operations and permanent erosion or sedimentation control features can follow immediately thereafter if the project conditions permit; otherwise temporary erosion or sedimentation control measures may be required between successive construction stages. Under no conditions shall a large surface area of credible earth material be exposed at one time by clearing and grubbing or excavation without prior approval of the Engineer.

The Engineer may limit the area of excavation, borrow and embankment operations in progress, commensurate with the Contractor's capability and progress in keeping the finish grading, mulching, seeding and other such permanent erosion, sedimentation and pollution control measures, in accordance with the accepted schedule.

Temporary erosion is sometimes caused due to the Contractor's negligence, carelessness or failure to install permanent controls. Sedimentation and pollution control measures then become necessary as a part of the work as scheduled or ordered by the Engineer, and these shall be carried out at the Contractor's own expense. Temporary erosion, sedimentation and pollution control work required, which is not attributed to the Contractor's negligence, carelessness or failure to install permanent controls, will be performed as ordered by the Engineer.

Temporary erosion, sedimentation and pollution control may include construction work outside the right of way where such work is necessary as a result of road construction such as borrow pit operations, service roads and equipment storage sites.

The temporary erosion, sedimentation and pollution control features installed by the Contractor shall be maintained by him till these are needed, unless otherwise agreed by the Engineer.

APPENDIX 11: WORKERS SAFETY IN COMMON OPERATION AND DURING CONSTRUCTIONS

Housekeeping practices

1. Maintain washrooms and canteens clean
2. Always keep all walkways clear and unobstructed
3. Ensure that spillages of oil and greasy
4. Stack raw materials and finished products clear of walkways or inside roads
5. Do not leave tools on the floor or in any location where they can be easily dislodged
6. Keep windows and light fitting clean
7. Maintain the workplace floors dry and in a non-slippery condition
8. Provide and maintain proper drainage system to prevent water ponding
9. Use metal bins for oily and greasy rags and store all flammable materials in appropriate bins, racks or cabinets. Ensure that the metal bins for storing oily and grease rags should be covered with lids.
10. Ensure that protruding nails in boards or walls are moved or bent over so that they do not constitute a hazard to people
11. Make sure that hazardous/dangerous chemicals are kept in the goods stores with the appropriate labeling, display of the material-safety-datasheet (MSDS) and other precautionary measures
12. Display "no smoking" signs in areas with high fire risks, e.g. paint stores, wood working area and others

Safe layout in the construction plant, camp and quarry areas

1. Arrange border to perimeter fencing
2. Ensure good visibility and safe access at site entrances
3. Provide adequate warning signs at the entrance and exit where necessary
4. Provide adequate space/area for loading and unloading, storage of materials, plant and machinery
5. Display emergency procedure and statutory notices at conspicuous location
6. Consider welfare facilities required
7. Provide areas for dumping garbage and other waste materials, and also arrange for their regular clearance.
8. Arrange storage, transport and use of fuel, other flammable materials and explosives in line with the license requirements to be obtained from appropriate authorities
9. Plan emergency assembly points, fire escape routes and locate fire-fighting equipment
10. Provide access roads and plant movement areas within the site.
11. Ensure the availability of first aid facilities and display notices at the various works to show the location of these facilities
12. Provide proper drainage and sewage & drainage facilities

Tree felling

1. Use hard hats during tree felling
2. Ensure tools such as the axes are in good condition
3. Determine proper foot and body position when using the axe. Do not cut above your head
4. Wear appropriate foot protection
5. Carry a first aid kit to the site
6. Determine possible hazards in the area, e.g. electrical or telephone or other utility lines
7. Prior to felling, determine the safest direction for the fall
8. Determine the proper hinge size before directing the tree fall.

Noise hazards and its control

Note that indications of noise levels are:

- You have to shout to be heard;
 - Your hearing is dulled just after work;
 - You get head noises or ringing in the ears after work;
 - You have difficulty hearing people while others are talking
1. Use sound level meters to measure. If the sound level exceeds 85 dB(A), then preventive measures should be taken
 2. Make personnel aware of noisy areas by using suitable warning signs and insisting that ear protectors should necessarily be worn.
 3. Reduce noise at source by improved maintenance, replacing noisy machines, screening with noise absorbing material, making changes to the process/equipment, controlling machine speeds, ensuring that two noise-generating machines are not running at the same time, using cutting oils and hydraulic breakers.
 4. Appoint a competent person to carry out a detailed noise assessment of the site, designate ear protection zone, and give instructions on the necessary precautionary measures to be observed by site personnel, including the use of suitable type of ear protections.
 5. Wear and maintain earmuffs and ear plug as required
 6. In construction or repair work, noise should be kept to a low-level bearing in mind the disturbance to residents.

Road works

1. The use of signage is most important to caution the road users of possible unsafe conditions due to the road works.

2. Use the appropriate signage devices as required by the site conditions/situation. The devices include regulatory signs, delineators, barricades, cones, pavement markings, lanterns and traffic control lights.
3. In using signs, make sure that they are (i) simple, easy-to-understand and convey only one message, (ii) luminescent and with reflective properties, and iii) broad, prominent and of appropriate size.
4. In using barricades, make sure that you keep traffic away from work areas and you guide the drivers to keep along a safe, alternative path.
5. Ensure that proper personal protective equipment (PPE) is provided to all the workers.
6. Cover existing road signs and install new ones at appropriate locations taking into account the distances that would be required and reaction times.
7. Plan layout and traffic management so that hazard is not created.
8. Deploy flagmen, who control traffic at the work areas. The flag should be 600mm x 600mm fastened to a 1m length staff.
9. Flagmen should wear reflective safety vests along with hard hats
10. If required, use wireless devices for flagmen to co-ordinate from either ends of the road, where works are being carried out.

Electrical hazards in construction areas

1. Treat all wires as live wires
2. Never touch dangling wires, but report them to your manager
3. Unless you are a qualified electrician, do not attempt electrical repairs
4. Never use electrical equipment if your hands are wet or you are standing in water
5. If electrical equipment is sparking or smoking, turn the power off and report the condition to your supervisor
6. Never use electrical wires that have physical damage
7. Never allow equipment or traffic to run over electrical wires.

Use and storage of gas/lpg

1. Store filled gas/LPG cylinder in the open area, i.e. outside of the building
2. Transport, store, use and secure cylinders in upright position
3. Ensure proper ventilation at the ground level in locations where gas/LPG is in use
4. Avoid physical damage to the cylinders
5. Never weld or cut on or near the cylinders
6. Store empty cylinders secured and upright
7. Make sure that the cylinder is closed immediately after use
8. Investigate immediately if there is the smell of LPG or gas
9. Never use de stanchied gas/LPG on site.

10. Make sure that there is no other unrelated fire in the vicinity of the cylinder

Operation of excavators

1. Ensure that excavators are operated by authorized persons who have been adequately trained.
2. Prevent unauthorized movement or use of the excavators
3. Check regularly and maintain the machine thoroughly
4. Ensure that all relevant information, including those related to instruction, training, supervision and safe system of work are provided to the operators.
5. Ensure that the operation and maintenance manuals, manufacturer's specifications, inspection and maintenance logbooks are provided for the use of the mechanics, service engineers or other safety personnel during periodic maintenance, inspection and examination.
6. During tipping or running alongside the trenches, excavators must be provided with stop blocks.
7. Excavators must be rested on firm ground during operation
1. Avoid operating the machine too close to an overhang, deep ditch or hole and be alert to potential carving edges, falling rocks and slides, rough terrain and obstacles.
2. Locate and identify underground services by checking with all utility companies before excavations.
3. Ensure that all excavations are supervised by experienced and competent persons.
4. When reversing or in case the operator's view is restricted, adequate supervision and signaling should be provided.
5. Ensure that the type and capacity of the excavator are properly chosen for the intended purposes and site conditions. Never use a machine for any purposes other than it is designed for.
6. Check and report for excessive wear and any breakage of the bucket, blade, edge, tooth and other working tools of the excavator.
7. Check that all linkages/hinges are properly lubricated and ensure that the linkage pins are secured. Never use improper linkage pins.
8. Never dismount or mount a moving machine
9. Work only with adequate ventilation and lighting
10. Ensure that the protective front screen of the driving cabin is fixed in position during excavations to avoid eye injury to the operator.
11. Ensure switch-off of the unattended vehicle.

Operation of trucks and dumpers

1. Ensure that only trained, authorized and licensed drivers operate the vehicles
2. Enlist the help of another worker before reversing the vehicle
3. Switch-off the engine of an unattended vehicle

4. Lower the tipping bodies when the machine is unattended, but if it is necessary to leave them in the raised position, they should be blocked to prevent their fall.
5. Wear safety boots or shoes to avoid injuries during loading and unloading.
6. Carryout periodic servicing to the manufacturer's requirements. All records of maintenance and repairs should be in writing or kept on site.
7. Keep the vehicle tidy and the cabin free from tools and material, which might obstruct the controls.
8. Keep to speed limits.
9. No passenger should be carried on a dumper except the driver
10. Never drive the vehicle across a slope
11. Provide stop blocks when the vehicle is tipping into or running alongside excavations
12. Do not overload the vehicle.
13. Carry only well secured loads
14. Park only on level ground, in neutral with the parking brake applied
15. Never mount or dismount from a moving vehicle

Gas welding

1. Use the following personal protective equipment during welding
 - Face or hand shield fitted with filters
 - Goggles, particularly when chipping slag
 - Gloves long enough to protect wrists and forearms against heats, sparks, molten metal and radiation
 - High-top boots to prevent sparks from entering footwear.
2. Screen the work area with sturdy opaque or translucent materials because glare can cause eye injury.
3. Key for opening the acetylene cylinder valve must be on the valve stem while the cylinder is in use so that the cylinder valve may be immediately shut-off in an emergency.
4. Ventilate the workplace using air blowers and exhaust fans to remove poisonous fumes and gases that are given off during welding
5. Take precautions against flying sparks and hot slag where welding is being done near flammable materials and check the area before leaving.
6. Do not weld material degreased with solvents until completely dry.
7. Do not use gas cylinders for supporting work or as rollers
8. Do not use oil grease on oxygen cylinder fittings
9. Do not use cylinders with damaged valves.
10. Do not use too much force if valves are stuck.
11. Replace valve caps after use
12. Search for leaks in equipment by using a solution of soapy water.
13. Shut the cylinder valve if acetylene from a cylinder catches fire at the valve or regulator due to leakage at a connection.

14. Treat all gas cylinders as full unless you are sure otherwise.
15. Never attempt to transfer acetylene from one cylinder to another or attempt to refill an acetylene cylinder.
16. Place portable fire extinguishers near the welding area
17. Secure all cylinders against accidental displacement.
18. Always lift gas cylinders. Do not slide them along the ground or drop them from trucks.
19. Keep gas cylinders in vertical position both in storage and when in use
20. Keep the workplace dry, secure, free from combustible materials and obstruction.
21. Store the acetylene and oxygen cylinders separately, and in a proper store.
22. Keep the gas cylinders from source of heat, flammable materials, corrosive chemicals and fumes.

Manual handling and lifting

1. Use mechanical equipment in place of manual handling as far as possible.
2. Assess the manpower required to handle or lift the load safely and arrange the manpower accordingly.
3. In handling hazardous materials, the workers shall be informed of the hazards and safety precautions.
4. All relevant persons shall be trained in the proper methods of lifting and carrying.
5. Where teamwork is required, select the persons whose ages and physical builds are compatible for teaming up. Coordinate the actions of the team members by giving necessary instructions.
6. Always lighten or suitably shape the load for manual handling as far as possible. Keep a look out for splinters, sharp edges, loose banding and nails.
7. Clear path or obstruction and tripping hazards.
8. Stack and secure goods safely on trucks, otherwise they fall off and injure passers-by.
9. Use personal protective equipment such as gloves, safety shoes, etc.
10. Adopt the following procedure when you lift a load:
 11. Stand close to the object. Have a firm footing with feet spread on either side of the load.
 12. Bend the knees and keep your back as straight as you can
 13. Grasp object firmly. Be sure grip will not slip
 14. Breathe in and throw the shoulder backwards.
 15. Straighten the legs, continuing to keep the back as straight as you can.
 16. Hold object firmly close to the body
 17. Always lift smoothly. Avoid jerky motions. Turn with feet instead of twisting the back.

Handling chemicals and hazardous substances

1. Always substitute hazardous chemicals with harmless or less hazardous ones wherever possible.
2. Enclose the process using chemicals or provide other engineering controls such as local exhaust ventilation, a fume cupboard or a safety cabinet.

3. Exercise great care in the storage and use of chemicals because they may be explosive, poisonous, corrosive or combustible.
4. Separate different chemicals physically
5. Store chemicals classified as dangerous goods in a properly constructed and approved goods store. Keep proper records of all chemicals and hazardous substances delivered, stored and used on site.
6. Consider unknown substances and liquids as dangerous until proven otherwise.
7. All containers should be clearly labelled to indicate contents. Never use a wrongly labelled container for chemicals.
8. Prohibit smoking in the vicinity of dangerous chemicals
9. Ensure that you are wearing the correct personal protective equipment before you handle chemicals
10. Maintain the Material Safety Data Sheet of all chemicals for reference on safety precautions to be taken and the use of suitable PPE.
11. When opening containers, hold a rag over the cap or lid, as some volatile liquids tend to spurt up when released.
12. Wash before you eat and do not eat at the workplace.
13. If the skin is splashed with a chemical, rinse it immediately with plenty of clean water. Eye should be flushed thoroughly with water followed by immediate medical attention.
14. Eye fountain, emergency shower and breathing apparatus should be available in the vicinity of the workplace.
15. Safety instructions for handling emergency situations should be displayed prominently at both the storage and use locations.

First aid

1. Provide first aid boxes at every site
2. Ensure that training on the use of the first aid box is provided to a handful of staff working in the site.
3. Display the list of persons who are trained on providing first aid.
4. Ensure that every first aid box is marked plainly "First Aid" in English and local language.
5. The responsible person or first aider should replenish the contents of the first aid box as necessary.

Personal protective equipment

General

1. Consider the provision of personal protective equipment only after all measures for removing or controlling safety hazards have been provided reasonably impractical.
2. Ensure that enough personal protective equipment is provided and that they are readily available for every person who may need to use them.
3. The management should ensure that all persons make full and proper use of the personal protective equipment provided.
4. Provide instruction and training in the proper use and care of any specific protective equipment where necessary
5. Do not willfully misuse, interfere with or ill-treat any protective clothing and equipment provided.

6. Ensure that the personal protective equipment is in good condition. Report immediately any damage to the management for replacement. Always keep the personal protective equipment as clean as possible.

Eye protection

1. Issue eye protection equipment where there is a foreseeable risk of eye injury
2. Ensure an adequate supply of goggles/shields is available.
3. Keep the goggles clean and make sure they are good fit.
4. Do not watch welding operations unless your eyes are protected from the damaging effect of flash.

Head Protection

1. No person shall enter a construction site unless he is wearing a suitable safety helmet
2. Wear a safety helmet:
 - When there is the risk of being hit by falling objects
 - While on or near a construction site
 - During adverse weather conditions
 - When in any area designated as a ðhard hatö area.
3. Provide identification labels to all helmets in some way to prevent random exchange among wearers, with one helmet exclusive to each person.
4. Inspect helmets for cracks or sign of impact or rough treatment before each usage. Destroy, remove and replace all worn, defective or damaged helmets.

Hearing Protection

1. Provide ear plugs or earmuffs as required. Use re-usable ear plugs when the reduction required (15-25 dBA) is not excessive. Use earmuffs where a large attenuation of upto 40 dBA is demanded.
2. Do not use dry cotton wool for hearing protection because it cannot provide any.
3. Provide disposable ear plugs for infrequent visitors and ensure that they are never re-used.
4. Provide re-usable ear plugs for those who need to work continuously for a long period in a high noise area.
5. Use earmuffs with replaceable ear cushions because they deteriorate with age or may be damaged in use.
6. Avoid wearing spectacles with earmuffs.
7. Use soap and water or the recommended solvent for cleaning earmuffs.
8. Provide earmuffs for those who may need to get in and out of a high noise area frequently.

Respiratory protective equipment

1. Wear suitable repairable for protection when there is a potential for small particles entering the lungs, e.g. emptying of cement bags.
2. Provide training to all persons using the respirators for their correct fitting, use, limitations and symptoms of exposure.
3. Clean and inspect all respirators before and after use.
4. Store respirators properly when not in use.

Safety Footwear

1. Wear suitable footwear for work
2. Use safety footwear on site or in other dangerous areas
3. Wear suitable safety shoes or ankle boots when working anywhere where there is high risk of foot injuries from slippery or uneven ground, sharp objects, falling objects, etc.
4. All safety footwear, including safety shoes, ankle boots and rubber boots, should be fitted with steel toecaps.
5. Avoid wearing flip flops, high heeled shoes, slippers, light sport shoes in situations where there is a risk of foot injury.
6. Keep shoelace knots tight.

Hand Protection

1. Wear suitable gloves for selected activities such as welding & cutting and manual handling of materials & equipment.
2. Do not wear gloves where there is a risk of them becoming entangled in moving parts of machinery
3. Wash hands properly with disinfectant soap and clean water before drinking, eating or smoking. Wash hands immediately after each operation on site when the situation warrants.

Fire prevention, fighting and equipment

1. Before fire breaks out
2. Store flammable material in proper areas having adequate fire protection systems.
3. Display sufficient warning signs.
4. Train selected personnel to use these fire extinguishers
5. Inspect fire extinguishers regularly and replace as necessary
6. Fire escape route should always be kept clear and clearly indicated.
7. Know the escape route and assembly point.
8. Display escape route maps prominently on each floor
9. Carry out fire drill regularly. Designate fire officers
10. Install fire alarm wherever required and test regularly.
11. Provide sufficient exit signs at prominent locations for directing people to the escape staircases and routes.

When fire breaks out

1. Alert all persons
2. Put off the fire with appropriate fire extinguishers only when you are sure that you are safe to do so.
3. Escape if you are in danger through the fire escape route to assembly point
4. Fire officers to carry out head count at the assembly point.

Incident and accident investigations

1. Carry out the investigation as quickly as possible.
2. Conduct interviews with as many witnesses as necessary
3. Do not rely on any one sole source of evidence
4. Use the following tools:
Checklists for obtaining basic and typical information for accidents
 - Notebook
 - Tape records
 - Camera
 - Measuring tape
 - Special equipment for the particular investigation
5. Obtain answers to the following questions:
 - When did the accident occur?
 - Where did it occur?
 - Who was injured and what was damaged?
 - What caused the accident?
 - Why did it occur?
 - How could it have been prevented?
 - How can a recurrence be prevented?
6. Prepare a short but sufficient investigation report that contains the following:
 - A summary of what had happened
 - A summary of events prior to the accident
 - Information gathered during the investigation

- Details of witnesses
- Information on injury or loss sustained
- Conclusions and possible causes of the accident
- Recommendations to prevent recurrence
- Supporting materials (photos, diagrams, etc.)

Guidelines for workers safety during construction

S. No	Stage and Nature of Construction Hazard	Safety measures expected to be taken by the Contractors and Site Engineers
1	Excavation in soft loose & slushy soil above 2.00 m depth sliding of earth or collapsing of sides.	The Excavation beyond 1.5 m to 2.00 m to be done in steps of minimum 500 mm offsets as shown in Clause 2.18.2(b) and also planking and strutting should be done as in Clause 2.19.1.
2	Excavation in slippery area (waterlogged) ó The labour may fall or machinery on site may slip.	Try to dewater the area and spread minimum 150 mm thick sand layer to avoid slipping
3	Excavation in Rock where chiselling is involved ó The fall of hammer may injure the hand; small rock pieces may injure the eyes and legs.	For hammer work, only experienced and skilled labour should be employed. Chisel should not be allowed to be held by hand, while hammering but chisel holding clamp should be provided. The labour should be provided with goggles and leg cover to protect eyes and legs, from injuries due to small rock pieces.
4	Excavation for drain across road or manhole adjacent to a road ó chances of a passer by falling into the excavated portion	The area should be well barricaded & a red lamp provided at night. A watchman should be deputed to prevent any movement of persons, or vehicles.
5	During Excavation or sometimes even while concreting ó Snake bites or Scorpion stings ó	In places where the movement of snakes are more the contractor should provide the labour with gum boots, gloves etc. and make snake antidotes available on site. A particular care that must be taken on such site is to always keep a vehicle available on site to rush the patient to a doctor. This applies to snake stringed patients as well.
6	Centring (formwork) and scaffolding ó Formwork collapse while concreting or just before concreting especially when wooden bellies are used.	Many a times bellies joined give way due to weak joint. Hence the use of joined bellies should be restricted. Only 2 joined bellies out of 8 bellies should be allowed. In case of double staging for a Slab at a height, utmost care should be taken to see that the top belly rests on the bottom belly. A particular care that should be taken during each concreting operating of slabs and beams is that, one carpenter and two helpers with spare bellies, nails etc. should be deputed below the slab/beam that is being concreted to watch any disturbance in the supports of the formwork below during concreting and in case of any doubt the concreting should be stopped immediately and the form work strengthened. Never allow bricks below a belly to make up the required height. This is most dangerous.
7	Formwork for beams and slabs: The bottom of beam collapses and many a times brings down the slab as well, injuring the labour and supervision staff.	This case is noticed when slender bellies are used without bracing. In fact, no concreting should be allowed without bracing at 300 mm above ground, and at mid-way, in normal beams & slabs. The bracings should be for the support of beams as well as slabs.

S. No	Stage and Nature of Construction Hazard	Safety measures expected to be taken by the Contractors and Site Engineers
8	Formwork for sides of a slabóThe labour just rests his foot on the plank and loses balance and falls resulting a fatal accident.	This is noticed when the carpenter fixes the side shuttering of a slab with a plank just tied by binding wire to the steel reinforcements and by wooden pieces nailed in wall and plank. This is so weak a portion that with little pressure the plank gives way. Hence side shuttering should be done with a direct belly support from ground or floor, and the practice of tying planks with binding wire to the steel reinforcement should be totally avoided. A temporary railing along the periphery of slab will guard the life of labour and supervision staff.
9	Formwork for beams and slabsóOpening the form- workóAccident due to fall of materials during removing the forms.	In fact, this is a most dangerous work. One should be very careful while formwork is removed. Only trained carpenters should be deputed for the work. A safe resting place outside the area of slab as a temporary measure should be constructed from where the Slab can be removed safely. Removal of formwork during night should not be permitted under any circumstances.
10	ScaffoldingóFall of workman, Supervision Staff, Standing on Chalis not tied properly or tied only at one end. (Chalis mainly made of Bamboos).	This is a very common negligence on the part of labour who do scaffolding work. The Chalis on which they work either span over its complete length or is tied loosely and many a times at one end only. Hence, care must be taken that the Chali do not span over the full length, but some middle support should be provided and also the same is tied properly on both ends.
11	LaddersóBalli or bamboo ladders ó The horizontal member breaks and the person falls. Sometimes the top face just rests on wall and the whole ladder tilts causing an accident.	The ladders should be strong enough to bear the weight of a labour with materials on head. As far as possible a handrail should be provided at one end. The horizontal member should be preferably fixed with bolt& nuts or strong nails. When the ladder is placed across a wall the top portion should be tied firmly to a strong support so that the ladder does not move laterally.
12	Column ReinforcementsóColumn reinforcements mainly in independent footings collapses ó Injury to persons working nearby.	The tendency of bar-benders is to tie the vertical steel with coir rope or 8 mm steel rods as ties on all four sides of the column reinforcement. This method of supporting the column reinforcements results in a weak support. Hence, the column reinforcements should be supported by strong bellies on all four sides of reinforcements and as far as possible a combined platform should be constructed out of bellies over which the reinforcements can be supported.
13	Concreting chajjas ó When chajjas are concreted without care and on opening the formwork the chajja would collapse, causing injury to labour on top or bottom of chajja.	While concreting chajjas care must be taken that the labour does not stand on the reinforcement and disturb the position. Separate scaffolding must be tied over which the labour can stand and work without disturbing the reinforcements. The main reason is in chajja the steel is placed on top face but if the labour stands on the steel, it will bend and come to bottom face and hence the chajja will fall when form-work is removed, thus, causing injury to labour working on top, or bottom.
14	DismantlingóDismantled materials may fall on passer-by or the person engaged in	When work of demolition is to be taken up the area should be closed for all outsiders. No one should be allowed up to 50 m.

S. No	Stage and Nature of Construction Hazard	Safety measures expected to be taken by the Contractors and Site Engineers
	dismantling work may fall due to slipping. The dismantled materials may fall on persons working below.	from the place of demolition. The workers engaged in demolition should be asked to wear safety belts. Helmets must be worn by all the workers engaged in dismantling work. The place should be strictly guarded at night with red lights at prominent places, and watchman should be posted.
15	Electric-Connections/Cables etc. óHigh tension/L.T. Electric wire passing near the slab structure- while bending, lifting or tying reinforcements the bar benders may sustain the Electric Shock, causing fatal injury.	The work in such places should not be allowed to the workers themselves, but in such position the work must be executed under the strict supervision of a responsible Foreman or a Supervisor.
16	Electric Connections/Cables etc. óCables below ground may get punctured during excavation & thus electrocute the labour working. Similarly, when concreting is in progress the punctured cable may prone to be fatal to the labour.	Before taking up the work all available drawings should be studied, local enquiry to be made to know the position of cables and work in such area should be got executed under strict supervision of an experienced Foreman or a Supervisor.
17	Electric Connections/Cables etc. ó Temporary Electric lines near damp walls, near joinery stretched on a considerable length ó There is every chance that the wire may get cut due to usage and may develop short circuits/leakages etc. and may electrocute the person touching the wire accidentally.	The Electric wires should be maintained by an electrician who should regularly check-up the insulation of wires especially placed near steel items & damp areas. The temporary wiring should be supported properly. As far as possible a good quality wire should be used, this may not get damaged easily.
18	Electric and gas welding work ó Drilling, polishing work ó Done by temporary cables used on a number of works ó Due to the fact that the wires are old & when they come in contact with water even in the process of curing the surrounding area may get affected due to leakage in the electric current thus causing damage to the workers & supervision staff.	All wiring works to be inspected by experienced electrician. All wires to be properly insulated and fixed at height on temporary poles. No welding work should be permitted near damp area. The welders to be provided with welder's goggles & gloves. As far as possible machine in good condition should be used.
19	Construction Machinery & Lifts ó Concrete Mixers ó Safety precautions. A mixer with hopper tried to be operated by a helper could not release brake in time thus causing injury to the person near hopper- sometimes fatal one.	The Mixers with hopper should be operated by an experienced mixer operator and such mixers should not be allowed to be handled by a helper or a labour.
20	Construction Machinery & Lifts - Lifts - Safety precautions. (1) The lift pit if left unguarded the children of workers may fall in the pit resulting in fatal accident	(1) A brick protection wall of minimum 1.00 m height should be constructed around the Lift Pit, thus, preventing the children going near the pit. A special care should be taken to see that the children are not allowed to come near the machinery.
	(2) The manually operated brakes of the lift failed or the communication between	(2) The condition of the lift must be maintained properly. The lift operator should be well trained. The labour receiving the

S. No	Stage and Nature of Construction Hazard	Safety measures expected to be taken by the Contractors and Site Engineers
	the labour at the top and the liftman failed and thus, the lift was not controlled and resulted in fatal accident.	bucket at top should be smart and active enough to convey the message of stopping & releasing the lift-to-lift operator properly.
21	Water Storage Tank for general use & curing - chances of children of workers falling in the tank with fatal accident.	The water tanks constructed on site should be protected by at least 1.00 m high walls on four sides, so that the children do not fall.
22	Misuse of lift by labour and sometimes supervision staff the lifts that are meant for lifting materials used by labour to go to upper floors ó The labour thus traveling many a times get injured.	No person should be allowed to go to upper floors by lifts that are mainly meant for conveying the building materials. Fatal accidents have taken place due to above action of workers.
23	Site Cleaning ó Cleaning top floors of buildings ó Upper portion of any structure ó Throwing waste materials broken concrete pieces, brick bats, sand etc. straightway from top to ground injuring person below or even a passer-by.	This dangerous practice should not be allowed at all. The materials should be brought to the ground with the help of lift or the use of rope over pulley with a bucket, thus bringing down materials safely.
24	Bar bending work-Helpers of bar benders to follow short cut method, throw surplus steel pieces from top floors to ground and may cause fatal injuries.	This is a very bad practice. The helpers should bring the rods to ground with the help of lift or rope & pulley.

APPENDIX 12: STORAGE HANDLING, USE AND EMERGENCY RESPONSE FOR HAZARDOUS CHEMICALS

A1. REFUELING/MAINTENANCE PROCEDURE

- Truck or suitable containers will bring in all fuel and fluids. There will be no storage of fuel, oil or fluids within 100m (or 50m) of the permanent water line.
- Prior to re-fueling or maintenance, drip pans and containment pans will be placed under the equipment. Absorbent blankets may also be required to be placed under the equipment and hoses where there is a possibility of spillage to occur.
- All used oils or fluids will be properly contained and transported to appropriately licensed (authorized) disposal facilities;
- Following re-fueling and maintenance, the absorbent blankets (if any) and spill pans will be picked up and the fuel truck or container moved outside of the 100m (or 50m) wide area.

Emergency Spill Procedure

Should a spill occur, either through spillage or equipment failure, the applicable emergency spill procedure outlined in sections A-2 to A-4 must be followed.

A2. SPILL PROCEDURE (INSIDE THE STREAM)

In the case of a spill, overflow or release fluid into the stream waterway (whether water is flowing during the spill or not), do what is practical and safely possible to control the situation, then get help.

- **Stop the flow**
 - Stop the release into the stream waterway
 - Shutdown equipment
 - Close valves and pumps
 - Plug hoses
- **Remove Ignition Sources**
 - Shut off vehicles and other engines
 - Do not allow tiger torches, vehicles, smoking or other sources of ignition near the area. Keep a fire extinguisher on hand but keep it a safe distance away from the potential ignition source (if a fire starts, the extinguisher must be easily accessible).
- **Contract the environmental officer and initiate Emergency Response**
 - Notify the site supervisor and the Contractor's Environmental Officer as soon as possible
 - The Environmental Officer will review the situation and decide if Emergency Services like Fire Brigade are required
 - Appropriate parties to be notified of the spill are
 - The contractor's Project Manager
 - The Engineer through his designated Environmental Officer
 - The Client
 - Regulatory Agencies like Pollution Control Board, Municipal Authorities, as applicable.

- Site Safety Officer
- **Cleanup and Disposal**
 - Emergency Services will be engaged for the containment, cleanup and disposal of contamination release into the environment
- **Reporting**
 - The contractor's Environmental Officer will document the event and submit reports to the Engineer, the Client and appropriate regulatory agencies like the Pollution Control Board (s).
- **Procedure Review**
 - The Engineer will review the report, determine if changes are required to procedures and recommend implementation of all required changes.

A3. SPILL PROCEDURE (ON LAND)

In the case of a spill, overflow or release fluid onto land, do what is practical and safety possible to control the situation, and then get help.

- **Stop the flow**
 - Stop the release into the water body
 - Shut down equipment
 - Close valves and pumps
 - Plug hoses
- **Remove Ignition Sources**
 - Shut off vehicles and other engines
 - Do not allow tiger torches, vehicles, smoking or other sources of ignition near the area. Keep a fire extinguisher on hand but keep it a safe distance away from the potential ignition sources (if a fire starts the extinguisher must be easily accessible).
- **Contain the Spill**
 - Dike around the spill to contain the material
 - Spread absorbent or place a spill blanket on the spill
 - Enlist the help of personnel on site
 - Notify your supervisor as soon as possible
- **Notification**
 - Appropriate parties to be notified of the spill are:
 - The Contractor's Project Manager
 - The Engineer through his designated Environmental Officer
 - The Client
 - Regulatory Agencies like Pollution Control Board, Municipal Authorities, as applicable
 - Site Safety Coordinator

- **Cleanup and Disposal**
 - The Engineer's Environmental Officer will ensure that a proper cleanup and disposal method is determined.
- **Reporting**
 - The Contractor's Environmental Officer will document the event and submit reports to the Engineer, the Client and appropriate regulatory agencies like the Pollution Control Board (s).
- **Procedure Review**
 - The Engineer will review the report, determine if changes are required to procedures and recommend implementation of all required changes.

A4. SPILL PROCEDURE (WITHIN PONDS)

In the case of a spill, overflow or release fluid due to equipment or hose failure, do what is practical and safely possible to control the situation, then get help

- **Stop the flow**
 - Stop the release
 - Shut down equipment
 - Close valves and pumps
 - Plug hoses
- **Remove Ignition Sources**
 - Shut off vehicles and other engines
 - Do not allow tiger torches, vehicles, smoking or other sources of ignition near the area. Keep a fire extinguisher on hand but keep it a safe distance away from the potential ignition sources (if a fire starts the extinguisher must be easily accessible).
- **Contain the Spill**
 - Stop any pumps that may be moving the water from the area where the spill occurred
 - Enlist the help of personnel on site
 - Notify your supervisor as soon as possible
- **Notification**
 - Appropriate parties to be notified of the spill are:
 - The Contractor's Project Manager
 - The Engineer through his designated Environmental Officer
 - The Client
 - Regulatory Agencies like Pollution Control Board, Municipal Authorities, as applicable
 - Site Safety Coordinator
- **Cleanup and Disposal**

- The Engineer's Environmental Officer will ensure that a proper cleanup and disposal method is determined. Absorbent pads will soak up the spilled material. The pads will be contained and removed from site for disposal at a licensed (authorized) facility.
- **Reporting**
 - The Contractor's Environmental Officer will document the event and submit reports to the Engineer, the Client and appropriate regulatory agencies like the Pollution Control Board (s)
- **Procedure Review**
 - The Engineer will review the report; determine if changes are required to procedures and recommend implementation of all required changes.

APPENDIX-13 ENVIRONMENT COMPLIANCE CERTIFICATE

Project Name:

Date of Inspectioní

S. no	ESMP Provisions	Status		
		Unsatisfactory	Moderately satisfactory	Satisfactory
1	Provision of a personnel accountable for implementation of ESMP / Safety Measures with Contractor			
2	Consent of PCB to Establish HMP			
3	Consent of PCB to operate HMP			
4	Compliance of PCB Conditions for HMP installation and operation			
5	Whether compliance reported through monthly Progress report of Divisional Office of Executive Engineer			
6	PUC taken for all Construction Vehicles			
7	Concrete platform with trap bitumen boiler, Fuel Tank for HMP and generator set provided or not			
8	Precautions to prevent contamination of soil by emulsion, Bituminous, oil and lubricant taken while storing			
9	Providing cover to fine construction material & bituminous mix during transportation			
10	Borrow Areas:			
a	Borrow areas approved by department			
b	Existing land use			
c	Nos Opened			
d	Available Quantity			
e	Balance Quantity			
f	Nos of Borrow areas Rehabilitated			
11	Spoil and debrs disposal:			
a	Existing land use			
b	site approval status			
c	Closure and completion plan			
d	Current status			
12	Site specific traffic Safety management Plan:			
a	Contractor installed the warning / regulatory Traffic signs at the construction sites			
b	Is the arrangement adequate			

Project Name:

Date of Inspection:

S. no	ESMP Provisions	Status		
		Unsatisfactory	Moderately satisfactory	Satisfactory
13	Safety equipment i.e. helmet, gloves, gumboot, mask, earplugs etc. provided to workers			
14	Health Facility at camp and worksite i.e. First Aid kit & suitable vehicle for conveyance in case of emergency / accident			
15	Provision of labour camp with adequate sanitation & potable water facilities			
16	was sprinkling done to suppress dust			
17	Consent to establish / operation of crusher			
18	Fire precautions at Hot Mix Plant and site office			
19	Was Monitoring of environmental attributes done as per ESMP			
20	Status of drainage provision in camp area			
21	General House Keeping			

Environment Specialist

HPRIDC

Executive Engineer

CMU (Construction Management
Unit)

APPENDIX-14 SEPTIC TANK AND OIL INTERCEPTOR

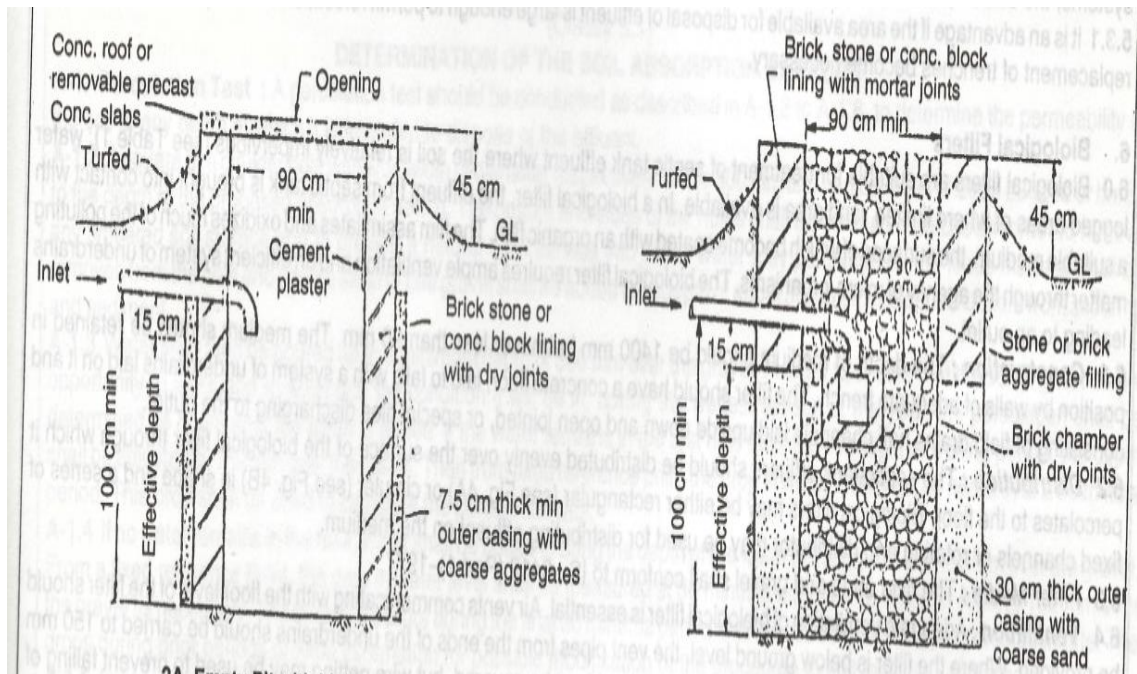
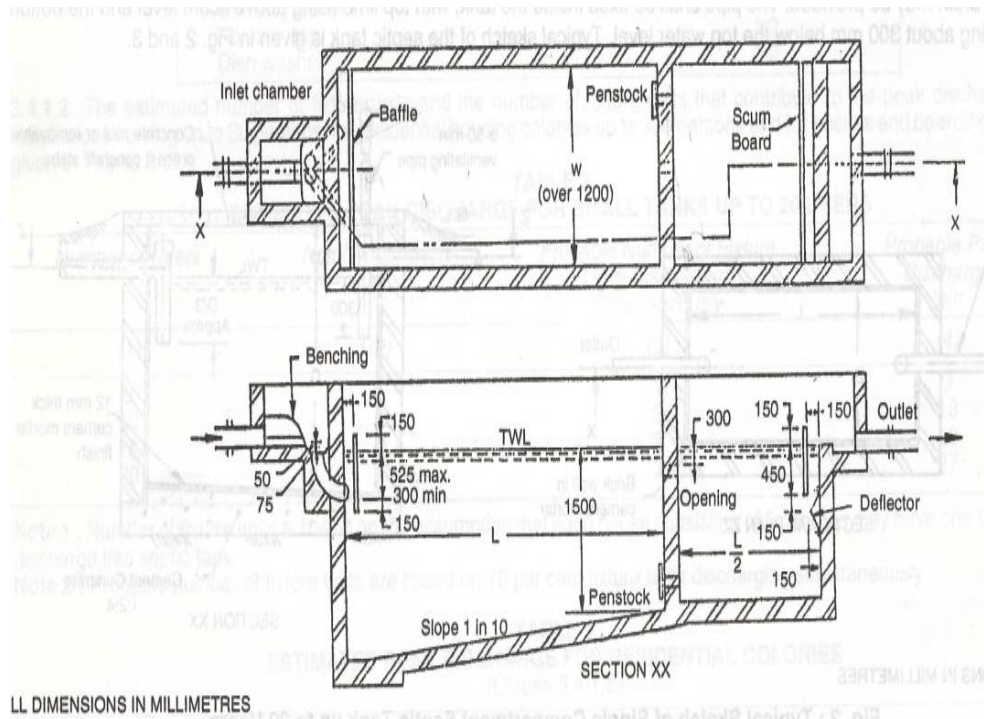

Figure. Septic Tank Specifications

OIL INTERCEPTOR

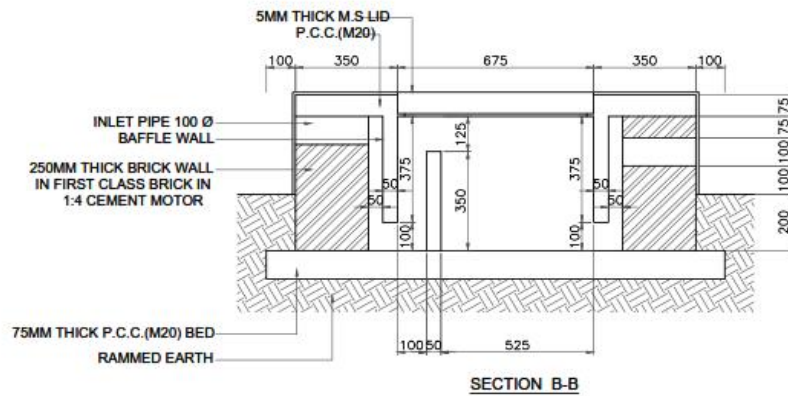
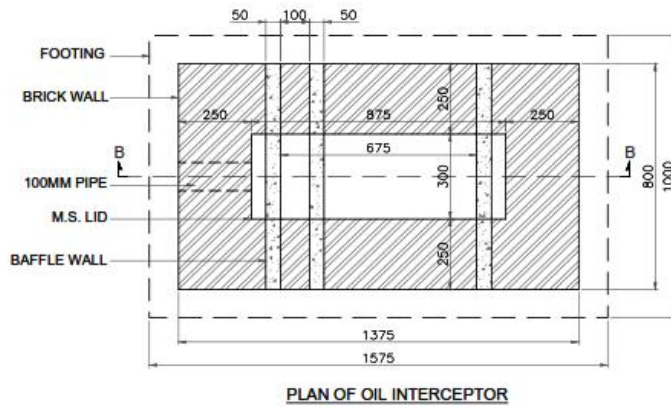
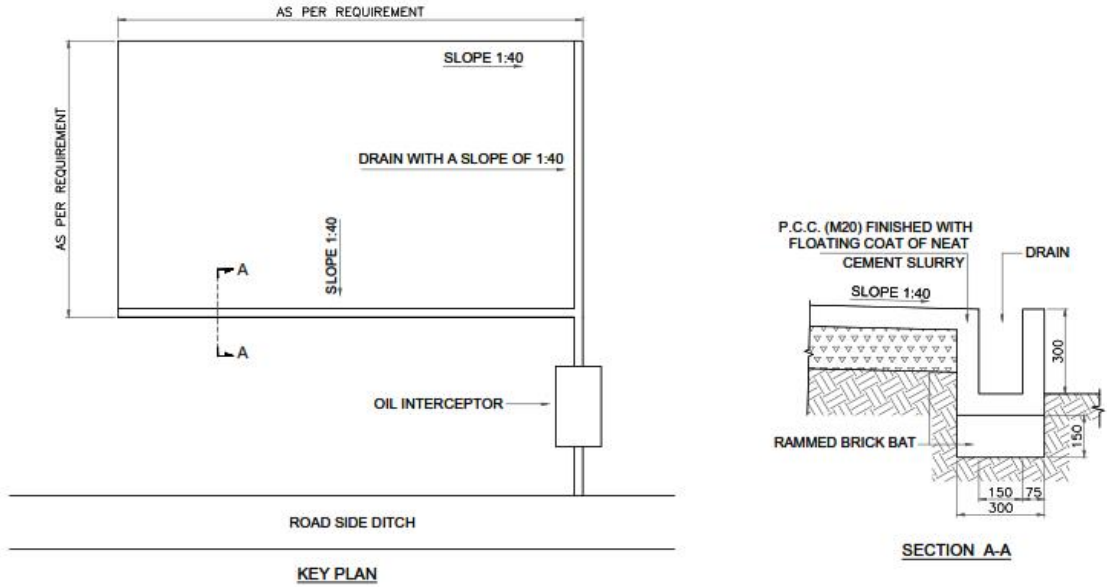

Figure. Oil Interceptor

APPENDIX 15: MANAGEMENT PLAN FOR LABOUR INFLUX

It is envisaged that during construction phase of the project, labourers for various road works will be hired through authorized manpower agencies by Contractor. As per ESIA for the project road, the migrant labour requirement will be around 150 for various road construction activities. Since these will be employed from outside the region and will therefore, be migrant labourers and hence, accommodation will be provided. These migrant labourers will be accommodated in a temporary campsite within the project area. This could result in stress on local resources, disruption in community relations, and movement of labours.

Objective:

The influx of migrant labour will have both negative and positive impacts on the nearby community and local environment. The labour will be accommodated in temporary campsite within the project boundary which can have significant interface with the nearby community. However, the influx of migrant workers would lead to a transient increase of population in the immediate vicinity of the project area for a limited time. This would put pressure on the local resources such as roads, fuel wood, water etc.

Hence, a plan has been designed to addresses specific activities that will be undertaken to minimize the impact on the local community, including elements such as worker codes of conduct, training programs on HIV/AIDS, etc

The Plan demonstrate the;

- Potential impacts associated with influx on the host population and receiving environment are minimized;
- Provision of safe and healthy working conditions, and a comfortable environment for migrant labour; and
- compliance with the ESS-2 (Labor and Working Conditions), ESS-4 (Community Health and Safety) of the WB ESMF and other national labor laws;

As per ESS-2, Labour and Working Conditions; it focuses on the protection of the basic rights of workers, fostering constructive worker-management relationships, as well as promoting fair treatment and the provision of a safe and healthy workplace.

As per ESS-4, Community Health and Safety; it focuses on minimization and management of health and safety risks to local communities; and to ensure that the project does not harm community health and safety

A Labour Influx Management Plan addresses specific activities that will be undertaken to minimize the impact on the local community, including elements such as worker codes of conduct, training programs on HIV/AIDS, etc

Potential Impacts due to labour influx:

Labor influx for construction works can lead to a variety of adverse social and environmental risks and impacts.

The environmental impacts listed below are more likely to be of relevant for project;

- **Inadequate waste disposal and illegal waste disposal sites;**

The project is located in rural environment and does not have sufficient local waste management capacities, which would likely lead to improper disposal practices.

- **Wastewater discharges;**

Project-related activities, along with workers' camps, and a lack of appropriate wastewater discharges may pollute nearby water resources.

- **Increased demand on freshwater resources;**

The provision of clean drinking water and water for hygiene purposes can result in increased pressure on freshwater resources in the project or camp site area.

- **Increased use of / demand for natural resources;**

This can include logging for construction, fuel wood collection, use of water resources, potential introduction of invasive or non-native species, and land degradation.

Adverse Social Impacts;

- **Risk of social conflict**

Conflicts may arise between the local community and the construction workers, which may be related to religious, cultural or ethnic differences, or based on competition for local resources.

- **Increased risk of illicit behavior and crime**

The influx of workers and service providers into communities may increase the rate of crimes and/or a perception of insecurity by the local community.

- **Increased risk of communicable diseases and burden on local health services**

The influx of people may bring communicable diseases to the project area, including sexually transmitted diseases (STDs), or the incoming workers may be exposed to diseases to which they have low resistance. This can result in an additional burden on local health resources. Workers with health concerns relating to substance abuse, mental issues or STDs may visit to local medical providers, thereby placing further stress on local resources.

- **Gender-based violence**

Construction workers are predominantly younger males. Those who are away from home on the construction job are typically separated from their family and act outside their normal sphere of social control. This can lead to inappropriate and criminal behavior, such as sexual harassment of women and girls, exploitative sexual relations, and illicit sexual relations with minors from the local community.

- **Increase in traffic and related accidents**

Delivery of supplies for construction workers and the transportation of workers can lead to an increase in traffic, rise in accidents, as well as additional burden on the transportation infrastructure.

Minimize Labour Influx

To minimize labor influx contractor need to identify a suitable labor pool locally, hence it will not require to bring in large numbers of laborers, which will not only limit negative impacts, but also reduce the contractor's costs as they will not need to provide as large a labor camp.

Management/Mitigations Measures;

All migrant workers are envisaged to be accommodated in temporary campsite within the project area. If

migrant workers are accompanied by their families, provisions should be made accordingly. Contractor shall ensure implementation of the following measures to minimise the potential negative impacts of worker accommodation and workers on local communities:

Cleanliness: Pest extermination, vector control and disinfection are to be carried out throughout the living facilities in compliance with local requirements and/or good practice.

Complaints and incident reporting: A formal Complaints Procedure will be implemented to ensure timely and transparent response to complaints as received from labour.

Labour education: The workforce will be sensitized to local social and cultural practices through provision of an induction course for all employees that stipulates expected behavior;

Labour behavior in campsite provided: A Code of Behavior governing appropriate behavior in the accommodation facilities to be kept in place and to be strictly enforced. The contractor shall ensure implementation of the rules of engagement between labours living in campsite and community and shall be implemented by construction contractors for all engaged labours. **Labour Compensation and Accommodation:** Client shall ensure that labours are provided with benefits such as annual leave, weekly rest day, etc.

Accommodation to be provided for the construction labour which cover facilities (including catering facilities, dining areas, washing and laundry facilities etc.) and supporting utilities.

Worker's Accommodation:

The CSC will supervise and monitor the activities performed by their contractor and accommodation facilities provided in the campsite. The following measures shall be provided:

- The labour will be provided with accommodation made of insulated material and locally available building material, etc.;
- The migrant workers with families shall be provided with individual accommodation comprising bedroom, sanitary and cooking facilities;
- The units will be supported by common latrines and bathing facilities duly segregated for male and female labour;
- Adequate number of toilets shall be provided in the accommodation facilities. A minimum of 1 unit to 15 males and 1 unit for 10 females shall be provided;
- The contractor shall provide a kitchen facility for the construction workers and the food will be of appropriate nutritional value and will consider religious/cultural backgrounds;
- All doors and windows shall be lockable and mobile partitions/curtains shall be provided for privacy;
- Facilities for the storage of personal belongings for workers shall be provided within the campsite only;
- Dustbins shall be provided for collection of garbage and will be removed on a daily basis;
- It is also required to provide first aid box in adequate numbers; and
- Ventilation should be appropriate for the climatic conditions and provide workers with a comfortable and healthy environment to rest and spend their spare time.

Security:

The contractor shall put in place the following security measures to ensure the safety of the workers. The following measures shall be incorporated:

- Access to the campsite shall be limited to the residing workforce;
- The contractor shall be responsible for deploying adequate number of guards;
- Adequate, day-time night-time lighting shall be provided;
- The security personnel shall be provided with training to respect the community traditions and in dealing with, use of force etc.; and
- The rental accommodation shall be provided with firefighting equipment and portable fireextinguishers.

Provision of Drinking Water

Access to an adequate and convenient supply of free potable water is necessity for workers. The domestic water supply shall be made available by the contractor.

- Safe drinking water conforming to the IS 10500:2012 for drinking water shall be provided;
- Private tanks can be utilized for provision of drinking water for the migrant labours;
- The direct usage of water from bore well should not be allowed and water shall be adequately treated;
- The Contractor should regularly monitor the quality of drinking water available; and
- All tanks used for the storage of drinking water are constructed and covered as to prevent water stored therein from becoming polluted or contaminated.

Cooking Arrangement:

The construction phase will involve engagement of large number of migrant people in the project area for a limited time. Hence, there shall be requirement of provision of cooking facilities (kitchen) as listed below:

- Places for food preparation are designed to permit good hygiene practices, including protection against contamination between and during food preparation;
- Adequate personal hygiene including designated areas for cleaning hands and cleaning of utensils; and
- All kitchen floors, ceiling and wall surfaces adjacent to or above food preparation and cooking areas are built using durable, non-absorbent, easily cleanable, non-toxic materials;
- Food preparation area to be durable, easily cleanable, non-corrosive surface made of non-toxic materials.

To ensure that the fuel need of labourers in the project area does not interfere with the local requirements, necessary arrangements for supply of cooking fuel to the labourers shall be done by the contractor. In case, fuel requirement for cooking purposes are only to be met by fuel wood then that must be purchased from authorized vendors.

Waste Water Generation:

There will of generation of wastewater from the campsite. About 80% of water used shall be generated as sewage/wastewater. Contractor shall ensure that the campsite are equipped with septic tank and soak pit for disposal of sewage or with mobile bio-toilets. It is also recommended that the storm water and sewage system should be separate. The surface water drainage shall include all necessary gutters, down pipes, gullies, traps, catch pits, manholes etc.

Sanitary and toilet facilities are constructed of materials that are easily cleanable. Sanitary and toilet facilities are required to be cleaned frequently and kept in working condition

Solid Waste Management:

The solid waste generated from campsite will mostly comprise of compostable wastes like vegetable residues (kitchen waste) and combustible waste like paper, cans, plastic and some non-degradable waste like glass/glass bottles.

Improper disposal of solid waste will lead to environmental degradation and health hazards to labour as well as nearby community.

The following measures shall be adopted by contractors for ensuring effective management of solid waste:

- The solid wastes of domestic nature generated shall be collected and stored separately in appropriate containers with proper sealing on them;
- Separate bins with proper markings in terms of recyclable or non- recyclable waste shall be provided in camp and kitchen premises in sufficient numbers for collection of garbage;
- Food waste and other refuse are to be adequately deposited in sealable containers and removed from the kitchen frequently to avoid accumulation. the local people in the vicinity can be contacted, if they needs it to feed domestic animals or for composting purposes.
- It is the responsibility of contractor to ensure safe disposal of all wastes generated out of labour camps.

Medical Facility:

Effective health management is necessary for preventing spread of communicable diseases among labour and within the adjoining community. The following medical facilities shall be provided by contractors for the construction workers:

- Adequate first aid kits shall be provided in the campsite in accessible place. The kit shall contain all type of medicines and dressing material;
- Contractor shall identify and train an adequate number of workers to provide first aid during medical emergencies;
- Regular health check-ups shall be carried out for the construction labourers every six month and health records shall be maintained.
- Information and awareness of communicable diseases, AIDS etc. shall be provided to workers.
- Basic collective social/rest spaces are provided to workers;

Inspection of camp sites:

Campsite shall be inspected at frequent intervals by Contractor's EHS officer to ensure that the facilities are well organized and maintained to acceptable and appropriate standards by the contractor. The key areas are:

- Daily sweeping of rooms and houses shall be undertaken;
- Regular cleaning of sanitary facilities shall be undertaken;
- The kitchen and canteen premises shall be established under good hygiene conditions;
- Daily meal times shall be fixed for the labor;
- Smoking and alcohol consumption shall be prohibited in the workplace;
- Water logging shall be prevented at areas near the accommodation facilities and adequate drainage is to be provided; and
- Checklists pertaining to the daily housekeeping schedule shall be maintained and displayed at houses, toilets and kitchen.

To limit the impact due to cumulative labour onsite during construction phase, contractor shall provide

adequate number of labour camps, which should be appropriate for its location and be clean, safe and, at a minimum, meet the basic needs of workers.

- Contractor should assess the location of labour camp, that it should not be constructed in immediate vicinity of any drainage channel;
- All tanks used for the storage of drinking and cooking water to be covered as to prevent water stored therein from becoming polluted or contaminated and all the migrant workers will be instructed accordingly;
- Contractor should ensure that accommodation which is provided is not overcrowded and does not pose a risk to the health and safety of workers;
- The labour camp will be equipped with septic tanks and soak pits and avoid presence of stagnant water is a factor of proliferation of potential disease vectors such as mosquitoes;
- Contractor should ensure that the disruption of local communities is minimum and if required limit the workers' movements in the nearby areas;
- Security staff should have a clear mandate and instructions about their duties and responsibilities such as not to harass, intimidate, discipline or discriminate against workers;
- Contractor should ensure that workers and members of the surrounding communities have specific means to raise concerns about security arrangement and staff;

Grievance Redress Mechanism:

A Grievance Redress Mechanism (GRM) shall be formulated for the construction labourers (local and migrant) comprising of a review committee including representatives elected by labour and management representatives. A documented GRM shall have the following elements:

- Proper system for lodging grievances;
- Provision for raising anonymous complaints;
- Appropriate level of management for addressing concerns;
- Workers have specific means to raise concerns about security arrangement and staff;
- Provision for timely action and feedback;
- Monitoring and review of grievances raised and action taken; and scope for continual improvement of the system.

APPENDIX-16: GOHP'S STRATEGY TO REHABILITATE AREAS INFESTED WITH INVASIVE ALIEN PLANT SPECIES (EXOTIC WEEDS) IN HIMACHAL PRADESH

Strategy to Rehabilitate Areas Infested with Invasive Alien Plant Species (Exotic Weeds) in Himachal Pradesh: A Concept Note

Introduction

Large scale invasion of the Himachal landscape by alien plant species over the past 20 odd years has become a cause of serious concern from the ecological, biodiversity, socio-economic and health point of view. Even as the list of alien plant species having become invasive in the State is fairly long, it is the following four exotic weed species that need priority attention:

a. *Lantana camara*L. (Lantana, Fulnu-buti, Panch-phulli, Ujrhu): This Tropical American species belongs to family Verbenaceae and has been declared as Weed of National Significance by more than 60 countries across the globe. It has come to occupy almost all the forest and non-forest areas in the sub-tropical belt in the State badly affecting the native floral diversity and availability of grass.

b. *Partheniumhysterophorus*L. (Carrot Weed, Congress Grass, Gajarghas, ChatakChandni): A member of family Asteraceae and a native of Tropical America, this herb is an aggressive colonizer of degraded areas with poor ground cover and exposed soil such as agricultural fallows, wastelands, roadsides, soil dumps, overgrazed pastures and degraded forests. The species, in addition to its adverse ecological impacts, has become a serious health hazard, causing allergic reactions in human beings.

c. *Ageratum conyzoides*L. (Goat Weed, Neel-phulnu): This noxious herb, a member of family Asteraceae, is a native of Tropical America. It has come to occupy agricultural fields, wastelands, plantations, pastures and all forest types, posing a serious threat to the indigenous vegetation in the State.

d. *Eupatorium adenophorum*Sp. (Crofton Weed): A member of family Asteraceae, this shrub is a native of Mexico. It forms dense thickets in fallow and wastelands, degraded forests and forest fringes out-spacing the indigenous species. The plant also causes allergic reactions and is a potential health hazard.

The above invasive alien plant species, with major incidence in the subtropical and lower temperate areas in the State, have come to affect the quality of forests and the pasture lands. What is more worrying is that their incidence seems to be increasing every year at a quite fast Speed of Spread. No wonder that the problem of alien weeds has been recognized as the priority management subject during this International Year of Forests, 2011. State's Grazing Advisory Committee has also been raising concerns about the spread of these weeds and their affect on the pasture lands and grass availability. The issue has also become a subject of regular discussion in the State Assembly.

Extent of Spread

A forest-wise reconnaissance, carried out during March 2011 across the State, has brought out that *Lantana* alone has invaded 1.5 lakh hectares of forest lands. Similarly, the other three main exotic weeds (*Parthenium*, *Ageratum*, *Eupatorium*) have been recorded to occur over 0.50 lakh hectares of forests, especially pastures.

In addition, these exotic weeds have also come to occupy most of the roadsides and the waste lands. The road length, passing through the sub-tropical/ lower temperate zone in the State being

approximately 20,000 kms with an average of 2.5 m berm on either side of these roads, the area under the exotic weeds along roadsides works out to an estimated 10,000 hectares. More than 80% of the exotic weed infestation along road sides is on account of *Parthenium*, *Ageratum* and *Eupatorium*.

Data about extent of spread of exotic noxious weeds on wastelands/ fallow lands is not available. However, assuming that the exotic weeds occupy most of the lands classified as barren/ unculturable; culturable wastes and fallow in the sub-tropical/ lower temperate zones (apprx. 1500 km²), the area under the exotic weeds on such lands works out to an estimated 1.5 lakh hectares. About 80% of this infestation is with *Parthenium*, *Ageratum* and *Eupatorium*.

An idea about the enormity of the problem at hand can be had from the consolidated figures presented in the table below:

Description of land	Estimated Infestation of Invasive Alien Species (Area in ha.)		Total (Area in ha.)
	Lantana	Others (<i>Parthenium</i> , <i>Ageratum</i> , <i>Eupatorium</i>)	
Forest land	1,50,000	50,000	2,00,000
Road sides	2,000	8,000	10,000
Lands classified as barren; cultivable wastes & fallow	25,000	1,25,000	1,50,000
Total (Area in ha.):	1,77,000	1,83,000	3,60,000

Analysis of the data presented in Table above reveals that whereas *Lantana* is the major noxious species of forest habitats under the administrative control of HP Forest Department, it is *Parthenium*, *Ageratum* and *Eupatorium* that form the major exotic weed species along road sides and on lands classified as barren, culturable wastes and fallow, major chunk of which is privately owned. Whereas the incidence of *Parthenium* is largely restricted to degraded and newly opened drier sites along roads and forest fringes, the other three invasive alien species tend to occupy all possible vacant places even under tree canopy. Even as *Eupatorium* and *Ageratum* show a clear preference for moister locales and show gregarious occurrence, at many places these share the niche and grow in an intimate mix with *Lantana*. It is, therefore, imperative that the management strategy should focus on comprehensive rehabilitation of areas infested with exotic weeds and not merely limit itself to any specific exotic weed species.

Another issue that has emerged from the recent survey is the **Speed of Spread** of invasive alien species, with more than 40% of the infestation reported as having taken place over the past decade only. There being little control over the various extraneous factors contributing to the spread of exotic weeds, viz. cutting of lands for roads and projects, muck dumping, uncontrolled grazing, innate biological traits of weeds, etc. the infestation is still continuing at an alarming rate. The fast changing life style, that include abandoning of marginal farm lands and voluntary keeping the surrounds clear of weeds, has only added to the pace of spread of these exotic weeds.

Past Efforts at Management of Invasive Alien Species in the State

By H P Forest Department: Some efforts at management of these weeds, especially in the forests sector in the State and revolving around mechanical/ cultural and chemical methods, have been made. Limited efforts at use of *Lantana* for making low cost furniture, coal brickets and compost have also been made in the past.

However, these management efforts, revolving mainly around mechanical removal of the exotic weeds, have been too few and too far spread to create any significant impact. An idea about the scale of intervention can be had from the fact that over the past three years, only about 1,700 hectare of forest area has been tackled under the weed management program.

Moreover, these efforts were largely taken up as one time interventions at weed removal and were not focused on rehabilitation of the treated area. Most of the past efforts have not yielded desired results due to lack of focus on long-term follow up system.

Chemical methods (involving mainly application of glyphosate) at control of *Lantana/ Parthenium* were abandoned after initial trials due to concerns about their adverse environmental implications. Associating *Lantana* removal to use has also not found favour with the local communities, the outputs/ returns from using cut *Lantana* for furniture, bricketting or composting being not considered commensurate with the effort required for its use.

By Other Organizations: The Himachal Pradesh Agriculture University has been working to develop successful models of managing exotic weeds. It has also been, around Palampur, spearheading *Parthenium* eradication campaigns in association with educational institutions and civil society organizations. However, these campaigns have been too limited to create large scale impact.

Major learning from the past efforts at eradication of invasive alien plant species is that such efforts need to be integrated with rehabilitation of treated areas and should be of long-term duration for effective results.

Strategy for Management of Invasive Alien Species on Forest Lands

A two-day workshop was organized by the Himachal Pradesh Forest Department at Sundernagar on 22-23 April 2011 with a view to come out with the following broad outputs ó

- 1) documentation of species-wise/ forest-wise spread of major exotic weed species
- 2) documentation and review of the past efforts at weed management
- 3) emergence of a comprehensive strategy to rehabilitate the areas infested with the major weed species

The workshop was attended by the subject matter experts from within and outside Himachal Pradesh, forest managers, researchers, academicians, representatives of line departments and representatives of Civil Society Organisations. The workshop was inaugurated by Mr. Vinay Tandon, Pr. Chief Conservator of Forests, Himcahal Pradesh. Prof. R. K. Kohli, Chairman Botany Department, Punjab University and IUFRO Chair on Invasive Alien Species delivered the Key Note address. The highlight of the technical sessions was forest Circle-wise presentations by the Conservators of Forests, giving detailed status of exotic weeds on forest lands in their respective circles. The invited subject matter experts included Prof. N NAngiras (KV, Palampur), Prof. M K Seth (HPU, Shimla), Dr. S SSamant (G B Pant Institute, Mohal) and Dr. Kuldip Dogra (Research Fellow), who shared their experience related to the status and management strategies of exotic weeds. Mr. Santosh Kumar, Conservator of

Forests, Chandigarh presented a case study about successful *Lantana* management interventions in Sukhna Wildlife Sanctuary. Dr. Anjan Kalia (representing CSO, Palampur) shared his perspective regarding the need to undertake eradication of *Parthenium* through 'people's movement'

The two day deliberations on the issue resulted in the emergence of a draft strategy for management of exotic weeds in the State, highlights of which are presented below:

Core Principles of the Strategy are set out as below

- Contain Further Spread:

To set up biennial monitoring protocols to keep watch over the spread of exotic weeds and take immediate remedial measures to remove recent infestations, if any.

- Complete Rehabilitation of Infested Areas:

It will involve shift from the present methods of 'one time removal of weeds' to 'complete rehabilitation' of the treated areas. Under this approach all the four above mentioned noxious exotic weeds will be tackled simultaneously. For this a comprehensive system of long-term follow up action with appropriate budgetary support will be evolved.

- Reliance on only Mechanical/ Manual Methods:

In view of their environmental/ ecological concerns, the rehabilitation measures will NOT employ any Chemicals/ Biological methods of exotic weed control.

- Natural Resilience of Native Flora to be the basis of Rehabilitation Action:

The natural regeneration of indigenous plant species on treated sites will be encouraged and facilitated to establish towards better environmental and ecological services, including fodder, fuel, water recharge, etc.

- No Exotic Plant Species to be used to Rehabilitate Treated Sites.

*No potentially invasive exotic species – (viz. *Leucaena leucocephala*, *Prosopis juliflora*, Teak, Darek, Silver Oak, *Jatropha curcus*, *Tecomastans*, etc.) – will be used for plantations in the areas under weed management, because of their deleterious effect on the native flora.*

- Rehabilitation to start from Low Intensity Infestation Areas and to progress towards areas with Heavy Infestation:

Rehabilitation activities will start from the fringes of infestation zone with lower intensity infestation and will progress towards the heavily infestation areas. This approach will (i) allow tackling larger areas with the given financial resources and result in creating quick visible impact, and (ii) help in containing further spread of exotic weeds.

- Priority Rehabilitation of Heavily Infested Critical Habitats:

*Rehabilitation of heavily infested areas as starting point will be taken up only in limited number of carefully selected **critical habitats** like grazing grounds near habitations. Such sites will then act as nucleus from where rehabilitation activity will radiate to adjoining areas of high infestation.*

- Multi-Stakeholder Participation:

Since all landscape elements in the State are already infested with noxious exotic weeds, the departments/ agencies dealing with different land use elements would need to join hands to effectively tackle this menace.

- Working under Campaign Mode:

The problem being enormous, it would need building larger societal consensus and engaging civil society organizations and local people/ social groups to effectively tackle this problem. It is possible under a campaign mode for which viable implementation mechanism would be evolved.

Methods for Strategy Implementation

- Forest Beat will be the Unit for Rehabilitating Exotic Weed Infested Areas:

It will create comprehensive visible impact and show quick results of rehabilitation action.

- *Forest beats with lowest infestation will be selected first.*
- *Within the selected beat, rehabilitation action will start from the areas with least infestation.*
- *Heavily infested critical habitat in the selected beat, if any needed to be tackled on priority basis, will be selected/ approved by the concerned DFO.*
- *Financial resources available for the purpose under various schemes will be converged to rehabilitate all areas under the selected beat in the shortest possible time.*
- All Noxious Exotic Weed Species will be Tackled Simultaneously:
All the noxious exotic weeds will be tackled simultaneously on the selected area to ensure complete rehabilitation of the infested areas.
- Method of Removing Exotic Weeds will be as under:
The invasive plant species will be removed by employing only mechanical/ manual methods, as given below:
 - *Lantana will be cut by using Cut Root Stock (CRS) method i.e. cutting the bushes below the soil to prevent coppicing (Annexure-II).*
 - *Other exotic weeds will be uprooted/ cut along the ground.*
- The following will be standardized for effective implementation of exotic weed management initiative:
 - *Cutting tools/ techniques*
 - *Calendar of rehabilitation activities*
 - *Cost models*
- A three year intensive maintenance of the treated areas and periodic follow up (every 3 years?) thereafter will form integral part of the rehabilitation program till the areas gets fully rehabilitated.
- Local people, through existing community groups, will be actively engaged to participate in rehabilitation of exotic weed infested areas.

Funding Options

The State Forest Department will explore funding possibilities for this initiative under State CAMPA/ NPV funds; Centrally Sponsored Schemes (Control & Eradication of Forest Invasive Species under Intensification of Forest Management Program); Regular Departmental Plantation Schemes; and MNREGA.

State CAMPA/ NPV: An initial allocation for rehabilitation of 1000 hectares per year under State CAMPA/ NPV funds has already been made.

CAT Plans: Rehabilitation of areas infested with invasive alien plant species also forms integral part of some of the CAT Plans (e.g. UHL Stage-III). There is a need to work out the total areas to be tackled for the purpose under various CAT Plans in the State to know the total extent of areas being tackled under this budget head.

MNREGA: This scheme offers a great potential for management of exotic weed infested areas. However, there are certain issues that need to be sorted out for achieving effective results. The major issues being (a) inclusion of exotic weed removal as integral part of the Panchayat's annual development agenda, (b) making available able bodied registered beneficiaries at right time of the year to handle this strenuous work, often away from the habitations (c) incorporation of nursery raising as one of the approved activities under the scheme, (d) provision for at least three year maintenance of the treated areas.

Management of Invasive Alien Species on Non-Forest Lands

As already brought out, a large chunk of non-forest land mass in the State is also facing increasing invasion of alien plant species. The situation is especially severe along road sides and waste lands/fallow lands where heavy infestation by noxious exotic weeds has not only resulted in reduction in the traditional grazing grounds but has also become a cause of serious health hazard.

The State Rural Development Department, Agriculture Department, Horticulture Department, Public Works Department and the Municipal bodies will initiate appropriate measures for management of noxious weeds on non-forest areas based on the broad strategy principles as brought out above.

It is expected that the above strategy will effectively guide the program to manage invasive alien plant species in the State in a time bound manner.

Forest Circle-wise incidence of exotic weeds on forest lands, as recorded during January-March 2011, is given in below table.

Circle-Wise Incidence of Exotic Weed Infestation in Forest Areas
(based on field data collected by field offices during January-March 2011)

Circle	Forest Area under the Invasion of				
	<i>Lantana</i>	<i>Ageratum</i>	<i>Parthenium</i>	<i>Eupatorium</i>	Total
Nahan	21,456.99	4,302.51	4,260.73	595.87	30,616.10
Bilaspur	55,941.55	0	0	0	55,941.55
Mandi	7,900.00	2,360.00			10,260.00
Hamirpur	12,680.00	0	0	0	12,680.00
Dharamshala	47,403.00	12,810.00			60,213.00
Shimla	4,060.89	0	1,100.00	0	5,160.89
Rampur	0	0	0	0	0
Chamba	4,631.77	132.91	68.5	85.4	4,918.58
Kullu	575.7	0	284.3	137.25	997.25
WL (S)	475.06	683.98	611.44	190.5	1,960.98
WL (N)	1,160.00	54	0	1,239.00	2,453.00
WL (GHNP)	0	0	0	0	0
Total	1,56,284.96	20,343.40	6,324.97	2,248.02	1,85,201.35

Note:

1. As the data was collected during winter months when species like *Eupatorium* & *Parthenium* are still in dormancy, their incidence seems to be under-reported.
2. More than one species of exotic weeds seem to occur either in an intimate mixture or in distinct gregarious patches in the same forest.
3. Thus, any strategy for their management needs to be focus on rehabilitation of areas by simultaneously removing all exotic weed species and should not be species specific.

Compiled by:

CCF (Fl. Div., NTFP & Res. Mgmt.)

Sundernagar

Method for Removal of *Lantana*

Removal of adult clumps using ‘Cut Root Stock’ (CRS) method: This method involves cutting the main tap root of *Lantana* plant beneath the coppicing zone (transition zone between stem base and rootstock). This method of removal involves engagement of 263 individuals to work in a group for the removal of *Lantana* if the clumps are too large to be handled by one individual after the rootstock is cut. The steps involved in the cut rootstock method are:

- (i) The person, who engages in removal of *Lantana*, is positioned in a way that he stands near centre of the *Lantana* clump with his back facing the clump and holding the handle of digger (kudal).
- (ii) Using the specially designed digger, the person cuts the main rootstock of *Lantana* 365 cm below the soil surface by hitting the rootstock 3 or 4 times; while hitting the rootstock the blade of the digger gets lodged into the main tap root, and at this point it is useful to move the handle of the digger in the forward direction away from the body of the person so as to sever the connection of the clump with the main tap root. In case the clumps of *Lantana* form impenetrable thickets, it is advantageous to cut the rootstocks of 364 contiguous clumps to make the removal operation convenient. It may be noted that the branches of *Lantana* clumps should not be slashed/cut to gain access to the centre of the clump for its removal by cut rootstock method. The branches of *Lantana* thicket formed by more than one clump should be lifted and tipped over from one end by using a wooden or bamboo pole of about 1.562.5 m long and diameter 566 cm which is inserted just below the branches from one side and rolled over easily by two workers holding the pole at either end and pressing it so as to reach the centre of the clump.

Such manual handling of impenetrable thicket makes it possible to reach the centre of clump easily, as otherwise its umbrella type canopy makes it difficult to reach the main stem. Such physical manoeuvre also minimizes or prevents regeneration from rooted cut branches when they fall on the ground.

- (i) Lift the clump/(s) and place the clump/(s) upside down. If the clump is not placed upside down, the prostrate rooted branches and the aerial old branches having aerial roots at nodes may develop into adult plants when they come in contact with the soil. Therefore, the upside down orientation of cut clumps is critical in the prevention of regeneration of *Lantana* from cut clumps. It may be noted that *Lantana* does not produce root suckers.

After drying the clumps, the clumps may be used as fuel or burnt at the same site or all the dried clumps may be collected at one place and then burnt. The best time for removal of *Lantana* is just before rainy season, i.e. when the plants are not in flowering and fruits.

APPENDIX-17:DISASTER MANAGEMENT & EMERGENCY RESPONSE PLAN AT PROJECT ROAD LEVEL

1. Disaster Management Plan¹ of Mandi District

Disaster Management has undergone a paradigm shift in recent years from the earlier approach of response to disasters to the current holistic approach of disaster mitigation and preparedness, which yields long term benefits while minimizing damage due to disasters. District Disaster Management Authority working under the aegis of Office of the Deputy Commissioner, Mandi is primarily responsible for disaster management in District Mandi. The District Authority is responsible for planning, coordination and implementation of disaster management and to take such measures for disaster management as provided in the guidelines.

The District Disaster Management Plan (DDMP) for Mandi district has been prepared for implementation by the Government and other non-Government agencies who would be involved in execution of the Plan during any disaster in the district. The plan indicates emergency action plans, roles and responsibilities of key personnel and suggests mitigation measures during any natural or manmade disaster, taking into consideration the available resources with various agencies involved. The plan evolves systems to make the plan an effective response mechanism. In short, the plan brings under one roof, various agencies and departments to control any type of disaster.

2. Aims & Objectives of District Disaster Management Plan

The overall aim of this plan is to facilitate action by different stake holder to mitigate disaster risk and strengthen preparedness and capacity building for a coordinated response. A formal plan for managing disasters is therefore necessary.

- The aim of this plan is to put in place a comprehensive disaster risk assessment.
- It further seeks to identify and clarify the roles and responsibilities of the internal and external stakeholder throughout the entire cycle of disaster management, i.e., pre-disaster, during disaster and post disaster phases.

The basic objectives for formulating a Plan are as under:

The basic objective of the District Disaster Management Plan is to protect all the residents of the district and all property from all sorts of untoward incidents through the following objectives:

- **Clarifying Authority, Responsibility and Relationships:-**
Clarifying as to who is responsible for ensuring that the work gets done, distributing and decision making authority among the team members and the existing organizational units, and establishing formal lines of communication.
- **Obtaining Resources:-**
Obtaining funds, personnel, supplies and equipment necessary for doing the required activities.
- **Establishing the Control System:-**
Determining the nature of information, which is necessary for carrying out activities, identifying source of such information and setting up reporting systems for Disaster Management.
- **Monitoring, Evaluation and Updation:-**
The plan needs to be monitored from time to time and updated.

3. Authority for the DDMP: DM Act 2005

On 23rd December 2005, the Government of India took a defining step by enacting the Disaster Management Act, 2005, which envisaged creation of Authorities at all three levels as below:

- National Disaster Management Authority (NDMA),

¹ Information abstracted from District Disaster Management Plan, Mandi

- State Disaster Management Authorities (SDMA),
- District Disaster Management Authorities (DDMA).

As per Section 31 of the DM Act 2005, there shall be a plan for disaster management for every district of the State. The District Plan shall be prepared by the District Authority, after consultation with the local authorities and having regard to the National Plan and the State Plan, to be approved by the State Authority.

The District Plan shall include:

- The areas in the district vulnerable to different forms of Disasters.
- The measures to be taken, for prevention and mitigation of disaster, by the Departments of the Government at the district level and local authorities in the district.
- The capacity building and preparedness measures required to be taken by the Departments of the Government at the district level and the local authorities in the district to respond to any threatening disaster situation or disaster.
- The response plans and procedures, in the event of a disaster, providing for-
 - Allocation of responsibilities to the Departments of the Government at the district level and the local authorities in the district.
 - Prompt response to disaster and relief thereof.
 - Procurement of essential resources.
 - Establishment of communication links; and
 - The dissemination of information to the public.

4. Evolution of the Plan

Preparation of the District Disaster Management Plan is the responsibility of the District Disaster Management Committee of the district. This plan is prepared using District Disaster Management Plan of Mandi 2012, Basic Primary data collected from all line departments during the time of pre-monsoon and pre-winter DDMA Meetings and input received from the UNDP workshop in June 2016 and the revised plan was reviewed in December 2016.

The main steps involved in the development of this plan are:

- Data analysis
- Discussion with experts
- Reference of national and international literature
- Mock exercise to check the viability and feasibility of the implementation methodology
- Wide circulation for public and departmental comments

5. Stakeholders & Responsibilities

At the District level, District Disaster Management Authority, with the Deputy Commissioner / District Collector designated as Response Officer (RO), and other line departments at district HQ are responsible to deal with all phases of disaster management within district. The role of the stakeholders has been prepared with the sole objective of making the concerned organizations understand their duties and responsibilities regarding disaster management at all levels and accomplishing them.

Sl. No.	Stakeholders	Responsibilities
1	NDMA	<ul style="list-style-type: none"> • To coordinate and monitor with the state for the implementation of the policies and plans related to Disaster management. • Coordinating DRR activities and implementation thereof.

Sl. No.	Stakeholders	Responsibilities
		<ul style="list-style-type: none"> Facilitating resources on demands rise by administration.
2	HPSDMA	<ul style="list-style-type: none"> Coordinating DRR activities and implementation thereof. Facilitating resources on demands rise by administration.
3	DDMAMandi	<ul style="list-style-type: none"> Update and implementation of DDMP. Conducting meetings on disaster management. Building capacity by trainings and awareness Managing all resources at district level Coordinating with stakeholders and liaisoning Enable local authorities to establish contact with
4	DEOC Mandi	<ul style="list-style-type: none"> System to collect, receive, and report and status of victims and assist family reunification. Enable local authorities to establish contact with the state authorities. Coordinate planning procedures between district, the state and the center. Provide ready formats for all reporting procedures as a standby.
5	Police Department	<ul style="list-style-type: none"> Having sound communication and security plan in place to coordinate law and order issues. Training to security personnel in handling disaster situations and issues related to them.
6	Home Guards	<ul style="list-style-type: none"> Support the primary agencies in responding during the incident Establish, maintain and manage search and rescue response system. Coordinate search and rescue logistics during field operations. Provide status reports of S&R updates throughout the affected areas.
7	Health and Family Welfare	<ul style="list-style-type: none"> To coordinate, direct and integrate State level response and activation of medical personnel, supplies and equipment. Provide human services under the Department of health. Prepare, check and keep ready Mobile Hospitals, stocks of equipment and drugs. To network with private health service providers. To provide resources for mass level water decontamination
8	HPSEB Ltd.	<ul style="list-style-type: none"> Provide and coordinate with State and support until the local authorities are prepared to handle all power related problems. Identify requirements of external equipment required such as DG sets, generators etc. Damage Assessment
9	Irrigation & Public Health	<ul style="list-style-type: none"> Procurement of clean drinking water. Transportation of water with minimum wastage. Special care for women with infants and pregnant women. Ensure sewer pipes and drainage are kept separate from drinking water lines.
10	Municipal Council	<ul style="list-style-type: none"> Land Usage planning Solid / liquid waste treatment and management

Sl. No.	Stakeholders	Responsibilities
		<ul style="list-style-type: none"> • Make arrangement for proposal disposal of waste in their respective areas. • Arrange adequate material and manpower to maintain cleanliness and hygiene
11	H.P PWD	<ul style="list-style-type: none"> • Emergency clearing of debris to enable reconnaissance, Clearing of roads. • Assemble casual labour; provide a work team carrying emergency tool kits, depending on the nature of disaster, essential equipment such as Towing vehicles, Earth moving equipment Cranes etc. • Construct temporary roads; Keep national and other main highways clear from disaster effects such as debris etc. • Coordination with private services providers for supply of earth moving equipment etc.
12	Rural Development	<ul style="list-style-type: none"> • Make arrangement for proposal disposal of waste in their respective areas. • Arrange adequate material and manpower to maintain cleanliness and hygiene.
13	BSNL Other Network	<ul style="list-style-type: none"> • Coordination of national actions to assure the provision of telecommunication support to the state and district. • Coordinate the requirement of temporary telecommunication in the affected areas.
14	Food and Public Distribution	<ul style="list-style-type: none"> • Identify requirement of food and clothing for affected population. • Control the quality and quantity of food, clothing and basic medicines • Ensure the timely distribution of food and clothing to the people. • Ensure that all food that is distributed is fit for human consumption.
15	Transport	<ul style="list-style-type: none"> • Overall coordination of the requirement of transport in implement emergency related response and recovery functions, search and rescue and damage assessment. • Make an inventory of vehicles available for various purposes;
16	Department of Public Relations	<ul style="list-style-type: none"> • To provide and collect reliable information on the status of the disaster and disaster victims for effective coordination. • Coordinate with all TV and radio networks to send news flashes for specific doø, donøts & needs. • Respect the socio-cultural and emotional state of the disaster victims while collecting information for dissemination.
17	Department of Animal Husbandry	<ul style="list-style-type: none"> • Treatment of animals (Domestic and Wild). • Provision of vaccination. • Disposal of dead animals;
18	Forest department	<ul style="list-style-type: none"> • Removal of fallen trees and Forestation or shifting of trees. • To provide fuel wood for the relief camps and public. • Have adequate storage of fuel wood and make arrangement for distribution thereof. • To provide fuel wood for cremation.
19	NDRF, Nurpur Armed Transit Camp at Pandoh	<ul style="list-style-type: none"> • Carrying out search and rescue on requisition by District as well as state administration. • Strengthening the response mechanism through trainings and awareness.

Sl. No.	Stakeholders	Responsibilities
		<ul style="list-style-type: none"> • Coordinate with administration in response as well as capacity building. • Facilitate administration with the key resources in disaster.
20	Revenue	<ul style="list-style-type: none"> • Training of Patwaris and field kanugoø with reference to disaster. • Gathering damage report from the ground through PRIø and patwaris. • Implementation of VDMPø

6. Hazard Profile of Mandi District

Mandi district is prone to severe Earthquake and other Natural Hazards like Floods, Hailstorm, Fire, Lightening and Manmade Disaster like Road Accident, etc. District Mandi has been traditionally vulnerable to hazards due to its geographical position they always contribute to a certain scale of damage, both in quantitative as well as qualitative terms. In simple words, a hazard is probability of occurrence of an event that has the potential for causing injury to life or damage to property or the environment. Mandi district lying along the left bank of the river Beas in the foothills of Shivalik ranges. Mandi district is prone to the following five types of hazards:

Types of Hazards	
Geologically	<ul style="list-style-type: none"> • Earthquake • Landslide and fluid flow • Dam failure
Water and climate	<ul style="list-style-type: none"> • Floods • Hailstorm • Heat wave and cold wave • Droughts • Thunder and lightning • Cloudburst
Chemical industrial and nuclear hazards	<ul style="list-style-type: none"> • Chemical and industrial disaster • Nuclear disaster
Accident-related hazards	<ul style="list-style-type: none"> • Forest Fire • Urban Fire • Major Building Collapse • Serial Bomb Blast • Festival related disasters • Electrical Disasters and Fires • Air, Road accidents • Boat Capsizing • Village Fire
Biologically Related hazards	<ul style="list-style-type: none"> • Pest Attacks • Cattle Epidemics • Food Poisoning

To help the local administration to work towards risk reduction and disaster resiliency, the first step is to prepare a hazard assessment for the district. Therefore, this section provides a detailed explanation of the hazards that, historically, have been hitting Mandi, as well as hazards to which the district is prone to due to geo-climatic characteristics.

The hazards faced by the district of Mandi are listed below. It is worth emphasizing that the main potential impacts associated with these hazards are high and can assume devastating proportions, both on social

7. Seasonal Mapping & Risk Matrix of Mandi District

The seasonal mapping & risk matrix of national hazards of Mandi district is given in table below. Floods are most likely to happen between June and sept, whereas Forest Fire in the months of April / May and September to November. Hazards, as earthquake, may occur at any time. It is important that the local administration plan accordingly - measures to mitigate the risks related to these hazards have to be taken in advance and the community trained well-before the probable period of each hazard.

Probability of Seasonal Hazards of Mandi District

Hazard	ProbableMonths											
	Jan	Feb	Mar	April	May	June	July	August	Sept	Oct	Nov	Dec
Flood												
ForestFire												
Drought												
Earthquake												
ColdEvent												
Heatwave												
Hailstorm												
HighWinds												
Roadaccident												

Risk matrix of the Mandi District

ElementsatRisk	DegreeofVulnerabilitytoVariousHazard							
	Earthquake	Land slide	Flash Floods / GLOF	Drought	Forest Fires	Domestic Fires	Dam Failure	Road Accidents
Community	High	High	High	Moderate	High	Moderate	Nil	High
Infrastructure	High	High	High	Moderate	Moderate	Moderate	Nil	Low
Houses	High	High	High	Nil	Low	Moderate	Nil	Nil
Social infrastructure	High	High	Moderate	Moderate	Low	Low	Nil	High
Livelihood Sector	Low	Low	Moderate	Moderate	High	Low	Nil	Nil
Environment	High	High	High	High	Very High	High	Nil	Low

8. Government Workforce for Disaster Management

Every department had nominated their Nodal Officer for the Disaster Management and the inventory is updated under the guidance of Nodal Officer. This workforce can act as a resource for disaster management in the district. However, this resource has yet not fully trained and oriented in DM and related issues. Hence their capacity to respond to disasters effectively and prepare a culture of prevention and safety would be less effective.

9. Fire Services and Home Guards

The Home Guards and Fire Services will be assigned an effective role in the field of disaster management. They will be deployed for community preparedness, conduct of mock drill and public awareness. A culture of voluntary reporting to duty stations in the event of any disaster will be promoted. The Fire Services upgraded to acquire multi-hazard rescue capability. The existing set up of these services would be strengthened to take up the new role more effectively.

10. Fire Stations & Fire Fighting Facilities

Mandi district has 5 fire service stations, to deal with the fire incidents with a manpower of 59 personnel, which includes 16 drivers and 10 vehicles. The fleet of fire brigades is as hereunder:

List of Fire Stations of Mandi District

Sl. No.	Resource	Quantity
1	FireVoguer	1
2	WaterTenders	3AdvanceFireTender
3	SmallWatertender	1
4	QuickResponseVehicle(QRV)	3

11. Home Guard Network

In case of major incidents Home Guards can be pressed to service as there are 876 Nos. of Home Guards. In any emergent situation Home Guards are readily available for deployment.

12. Police Stations

Number of Police stations & Police Chowki including details of their staff, list of equipment available, details of infrastructure including age or building (when was building made), details of medical facility available, details of food & water supply facility, about how many male & female toilets are there to cope up at the time of any disastrous condition. GIS mapping also in progress to mapped the available resources in the Mandi district.

List of Police Stations of Mandi District

Sl. No.	NameofPoliceStation	ContactNumber
1.	Aut	01905-228028
2.	Balh	01905-242268
3.	BslColonySundernagar	01907-262219
4.	Gohar	01907-250228
5.	JoginderNagar	01908-222065
6.	Karsog	01907-222221
7.	Padhar	01905-266634
8.	SadarMandi	01905-235536
9.	Sarkaghat	01905-230028
10.	SunderNagar	01907-266229

13. Medical Facilities in Mandi District

Detailed list of resources available in terms of Primary Health Centers, Community Health Centers, Ayurvedic Hospitals, Contact no of respective hospitals, Number of doctors in each health centers, no. of hospital staff, no of beds available in each hospital, list of available resources (Stretcher, first aid kit, wheelchair, Oxygen cylinder with trolley, body trolley, X-ray machine etc.) and other list like detail of blood banks, no of laboratories & age of the building. GIS mapping also in progress to mapped the available resources in the Mandi district.

Healthcare facilities in Mandi District

Sl. No.	Resource	Numbers
1	CommunityHealthCentre	13
2	PrimaryHealthCentre	70
3	AllopathicDispensaries	13
4	HealthSubCentre,	313
5	AyurvedicHospital,	02
6	Ayurvediccenter,	164
7	LeprosySub-Centre/Lab	01
8	DentalLaboratory	15
9	X-RayLaboratory	20
10	DeliveryandChildwelfare,	08
11	Doctors&Nurses	175
12	AllopathicDoctors	115
13	AyurvedicDoctors	58
14	Nurses	572
15	ASHAs	1224
16	AWWs	3004

Hospital Bed Capacities in Mandi District

Sl. No.	Particulars of Institutions	Block	Constituency	Area	Beds (Sanctioned)	Beds (In-Position)
1	NetajiSubhasChandra BoseZonalHospital,Mandi	Mandi	Mandi	Urban	300	300
2	CivilHospital,Sunder-Nagar	Sundernagar	Sundernagar	Urban	100	100
3.	CivilHospital,Sarkaghat	Gopalpur	Sarkaghat	Urban	100	77
4.	CivilHospital,JoginderNagar	Darang	JoginderNagar	Urban	100	75

List of Community Health Centers in Mandi District

Sl. No.	Particulars of Institutions	Block	Tehsil	Constituency	Area	Beds (Sanctioned)	Beds (In-Position)
1	Community Health Centre, Kotli	Rewalsar (Balh)	Kotli	Mandi	Rural	30	30
2	Community Health Centre, Baldwara	Gopalpur	Sarkaghat	Sarkaghat	Rural	30	30
3	Community Health Centre, Kataula	Mandi Sadar	Mandi Sadar	Darang	Rural	6	6
4	Community Health Centre, Nagwain	Mandi Sadar	Mandi Sadar	Darang	Rural	6	6
5	Community Health Centre, Ratti	Mandi Sadar	Mandi Sadar	Balh	Rural	30	23
6	Community Health Centre, Ladbharol	Chauntra	Ladbharol	Joginder Nagar	Rural	6	6
7	Community Health Centre, Bagsaid	Gohar	Chachiyot	Seraj	Rural	6	10
8	Community Health Centre, Dharampur	Dharampur	Dharampur	Dharampur	Rural	6	6
9	Community Health Centre, Mandap	Dharampur	Sarkaghat	Dharampur	Rural	-	-
10	Community Health Centre, Janjehli	Seraj	Chachiyot	Seraj	Rural	6	6
11	Community Health Centre, Dehar	Sundernagar	Sundernagar	Sundernagar	Rural	6	6
12	Community Health Center, Rohanda	Sundernagar	Sundernagar	Sundernagar	Rural	6	5
13	Community Health Centre, Nihari	Karsog	Nihari	Sundernagar	Rural	6	12
14	Civil Hospital, Padhar	Darang	Padhar	Darang	Rural	50	23
15	Civil Hospital, Karsog	Karsog	Karsog	Karsog	Rural	100	50
16	Civil Hospital, Sandhol	Dharampur	Dharampur	Dharampur	Rural	50	16
17	Civil Hospital, Gohar	Chachiyot	Chachiyot	Nachan	Rural	50	30

14. Institutional Structure at State Level

At the State level, the State Disaster Management Authority constituted under the chairmanship of the Chief Minister and has the responsibility of planning, policies, plans and guidelines for DM and coordinating their implementation for ensuring timely, effective and coordinated response to disasters. The Chief Secretary is the Chief Executive Officer of the SDMA. Besides, the SDMA has seven other members. The SDMA will, inter alia approve the State Plan in accordance with the guidelines laid down by the NDMA, approve DMPs prepared by the departments of the State Government, lay down guidelines

to be followed by the departments of the Government of the State for the purpose of integration of measures for prevention of disasters and mitigation in their development plans and projects, coordinate the implementation of the State Plan, recommend provision of funds for mitigation, preparedness measures, review the developmental plans of the different Departments of the State to ensure the integration of prevention, preparedness and mitigation measures and review the measures being taken for mitigation, capacity building and preparedness by the departments. The State Authority shall lay down detailed guidelines for providing standards of relief to persons affected by disaster in the State.

The State Executive Committee (SEC) headed by the Chief Secretary and four other Secretaries as its members shall be there to assist the SDMA in the performance of its functions. The SEC will further provide necessary technical assistance or give advice to District Authorities and local authorities for carrying out their functions effectively, advise the State Government regarding all financial matters in relation to disaster management, examine the construction, in any local area in the State and, if it is of the opinion that the standards laid for such construction for the prevention of disaster is not being or has not been followed, may direct the District authority or the local authority, as the case may be, to take such action as may be necessary to secure compliance of such standards, lay down, review and update State level response plans and guidelines and ensure that the district level plans are prepared, reviewed and updated, ensure that communication systems are in order and the disaster management drills are carried out periodically. The SEC will also provide information to the NDMA relating to different aspects of DM.

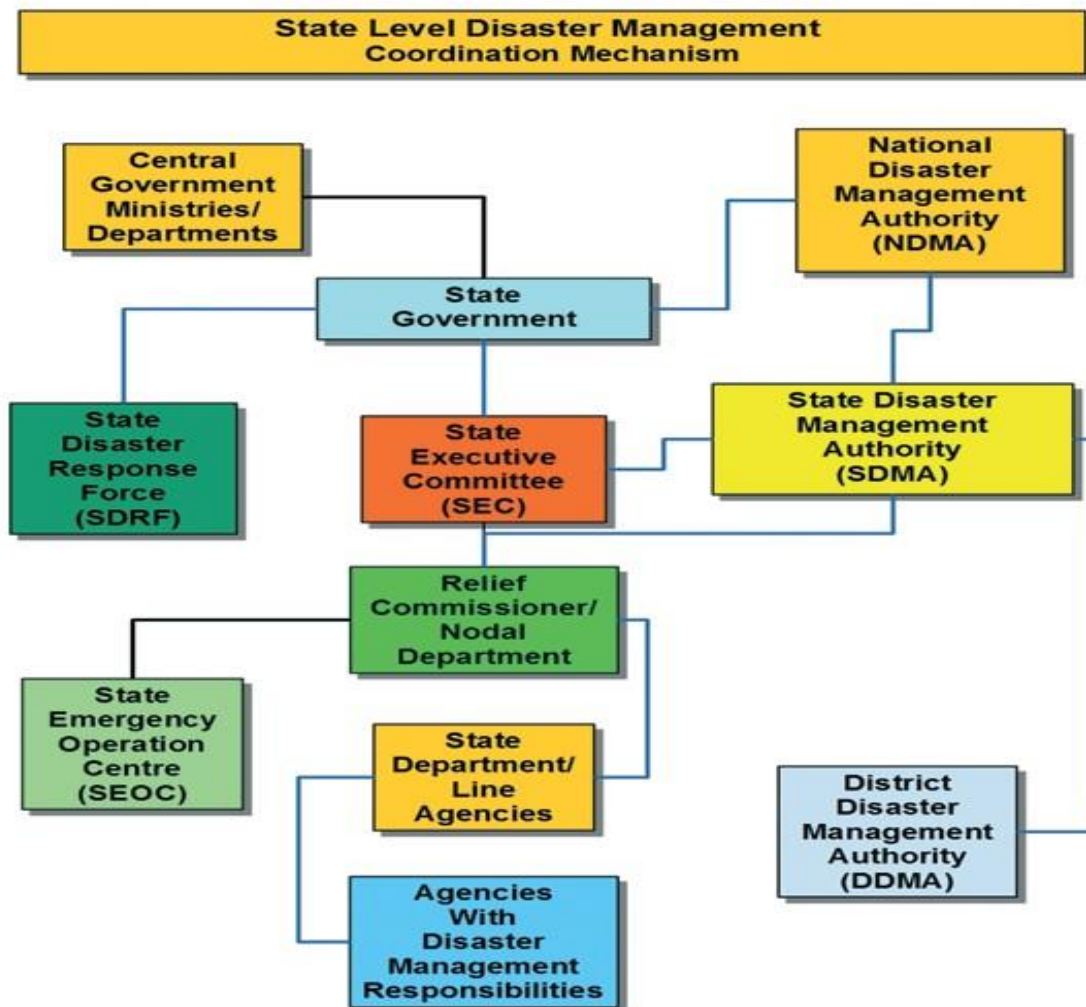

Fig 3: Institutional Arrangements for Disaster Management at State Level

15. State Disaster Management Authority

Members of State Disaster Management Authority

1.	Honøble Chief Minister	Chairman
2.	Honøble Revenue Minister	Member
3.	Chief Secretary	Chief Executive Officer, ex officio
4.	ACScumFC (Revenue)	Member
5.	Principal Secretary (Home)	Member
6.	Principal Secretary (PWD/I&PH)	Member
7.	Principal Secretary (Health)	Member
8.	Director General of Police	Member
9.	Secretary (Revenue)	Member Secretary

SDMA Roles and Responsibilities

As per Section (18) of Disaster Management Act 2005, SDMA has been designated by certain Roles and Responsibilities:

- Laying down policies and plans for disaster management within the State.
- Approve the disaster management plans prepared by the departments of the State Government.
- Lay down guidelines to be followed by the departments of the Government of the State for the purposes of integration of measures for prevention of disasters and mitigation in their development plans and projects and provide necessary technical assistance, therefore.
- Coordinate the implementation of the State Plan.
- Recommend provision of funds for mitigation and preparedness measures.
- Review the development plans of the different departments of the State and ensure that prevention and mitigation measures are integrated therein.
- Review the measures being taken for mitigation, capacity building and preparedness by the departments of the Government of the State and issue such guidelines as may be necessary

16. State Crisis Management Group

The crisis management group at State and districts level has been constituted for the State. The State Crisis Management Group (SCMG) is headed by the Chief Secretary. The SCMG shall normally handle all crisis situation and advice and guide the District Crisis Management Group (DCMG) also. The DCMG is headed by the District Magistrate and is responsible for on-scene management of the incident emergency.

The State Crisis Management Group's function are:

- To create a dedicated body that will assess, plan and implement the vital aspects of disaster management (Prevention, mitigation, preparedness and response).
- To ensure smooth coordination between Central and State Governments in the event of a disaster.
- To create a unified command, control and co-ordination structure for disaster management, integrating the various wings and agencies of government that are necessary for emergency response, as well as for preparedness, mitigation and prevention activities.

17. STATE EMERGENCY CONTROL ROOM / HIMACHAL PRADESH STATE DISASTER MANAGEMENT AUTHORITY

There is a State Emergency Control Room in the HP Secretariat, Chotta Shimla, Shimla, and Himachal Pradesh 171001 to provide Secretarial support to the Himachal Pradesh State Disaster Management Authority and facilitate the functioning of the Authority. 1070 is the Helpline Line No. of State Emergency Control room which is operational 24 x 7. This Control Room will receive the information from various

sources. It shall be in constant contact with the District Disaster Control Rooms, Police Control Rooms. The State Emergency Control Room will receive the information, record it properly and put up to the State Disaster Management Authority instantly.

Similarly, the instructions passed by the State Authority shall be conveyed to the addressees and a record maintained to that effect. The Himachal Pradesh State Disaster Management Authority is involved in the Management of large-scale Disasters. The Divisional Commissioner in consultation with other members of the Authority shall decide its involvement after the receipt of the report from the Deputy Commissioner of the Districts. NDRF Battalion located at Nurpur, District Kangra, HP and Bhatinda, Punjab have been given the responsibility for deployment in Mandi, Himachal Pradesh. Contact Details of NDRF have been given in the district disaster management plan.

Water and Climate Related Disasters		
Floods	Department of IPH	IMD, CWC, ES&T
Hailstorm	Department of Agriculture and Horticulture	IMD, Home, insurance and Revenue
Cloud Burst	Department of I and PH	IMD, CWC, ES&T, Revenue
Heat and Cold Wave	Department of Revenue	IMD, ADMN, forest, Health
Snow Avalanches	Snow and Avalanche Study Establishment (SASE), Manali (DRDO) / Deptt. of Home / ES&T	Tribal Admin, IMD, Health, Home and Revenue, Mountaineering Institute / S&T / GSI
Droughts	Department of Agriculture / IPH	IMD, Revenue, RD, Nauni and Palampur universities / Department of Land records
Thunder and Lightning	Department of Revenue	IMD / ES&T
Geology Related Disasters		
Landslides and Mudflows	Geological Wing of Department of Industries, PWD, BRO & UD	GSI, CRRI, Ministry of Earth Sciences, Wadia Institute of Geology, Wadia Institute of Himalayan Geology
Earthquakes	Department of Environment, Science and Technology	IMD, Ministry of Earth Sciences / GSI
Chemical and Industrial Disaster		
Chemical and Industrial Disasters	Department of industries / Department of labour and employment	HPSEB, Department Of labour & employment, Home, Admn, DMI Bhopal, and NDRF
Accident-Related Disasters		
Forest Fires	Forest Department	Fire Department, ES&T, Home and Admn
Urban Fires	Department of Home (Fire)	IPH, Health, TCPI, Admn and Home
Major Building Collapse	Department of UD	PWD, Health, Home and Admn
Electrical Disasters and Fires	HPSEB / MPP and Power	Home, Health and Revenue

18. INSTITUTIONAL STRUCTURE AT DISTRICT LEVEL

At the district level, the Deputy Commissioner / District Magistrate will be the focal point for coordinating all activities relating to prevention, mitigation and preparedness apart from his existing responsibilities pertaining to response and relief.

19. DISTRICT LEVEL MECHANISM IN MANDI DISTRICT

At District level, District Disaster Management Authority has been constituted under the notification of The Disaster Management Act 2005. The power of sanction of relief is also vested with the officials of revenue department at different level depending upon the need. The Deputy Commissioner/District Magistrate ensures participation of district and state government in the response and recovery phase.

20. DISTRICT DISASTER MANAGEMENT AUTHORITY (DDMA)

As per The Disaster Management Act 2005, each district has established a District Disaster Management Authority. The District Authority shall consist of the Chairperson and such number of other members, not exceeding seven, as may be prescribed by the State Government, and unless the rules otherwise provide, it shall consist of the following, namely:-

The DDMA for the district has been notified on 1.6.2007 as under:

1	Deputy Commissioner	Chairperson, ex officio
2	Elected Representative	Co-Chairperson, ex officio;
3	Superintendent of Police	Member
4	Chief Medical Officer	Member
5	Superintendent Engineer (I & PH)	Member
6	Superintendent Engineer (PWD)	Member
7	Chairman Zila Parishad	Member / Chief Executive Officer, ex
	Additional District Magistrate	

The District Authority shall act as the district planning; coordinating and implementing body for disaster management and take all measures for the purposes of disaster management in the district in accordance with the guidelines laid down by the National Authority and the State Authority and the roles and responsibilities of the DDMA have been elaborated in Section 30 of the DM Act, 2005.

DDMA Roles and Responsibilities

The roles and responsibilities of the DDMA have been elaborated in Section 30 of the DM Act, 2005. It will, internal perform the following roles and duties as per the act:

- Prepare, Coordinate and monitor a disaster management plan including district response plan for the district.
- Ensure that the areas in the district vulnerable to disasters are identified and measures for the prevention of disasters and the mitigation of its effects are undertaken by the departments of the Government at the district level as well as by the local authorities.
- Ensure that the guidelines for prevention of disasters, mitigation of its effects, preparedness and response measures as laid down by the National Authority and State Authority are followed by all the departments of Government at the district level and by the local authorities in the district.
- Review the state of capabilities for responding to any disaster or threatening disastrous situation in the district and give directions to the relevant departments or authorities for their up gradation as may be necessary.
- Organize and coordinate specialized training programmes for different levels of officers governmental and non-governmental organizations and voluntary rescue workers in the district.
- Set up, maintain, review and upgrade the mechanism for early warnings and dissemination of proper information to public.
- Ensure that the Departments of the Government at the district level and the local authorities prepare

their response plans in accordance with the district response plan.

- Lay down guidelines for, or give direction to, the concerned Department of the Government at the district level or any other authorities within the local limits of the district to take measures to respond effectively to any threatening disaster situation or disaster.
- Advise, assist and coordinate the activities of the Departments of the Government at the district level, statutory bodies and other governmental and non-governmental organizations in the district engaged in the disaster management.
- Provide necessary technical assistance or give advice to the local authorities in the district for carrying out their functions.
- Review development plans prepared by the Departments of the Government at the district level, statutory authorities or local authorities
- Identify buildings and places which could, in the event of any threatening disaster situation or disaster, be used as relief centers or camps and make arrangements for water supply and sanitation in such buildings or places.
- Establish stockpiles of relief and rescue materials or ensure preparedness to make such materials available at a short notice.
- Ensure communication systems are in order, and disaster management drills are carried out periodically.
- Perform such other functions as the State Government or State Authority may assign to it or as it deems necessary for disaster management in the district.

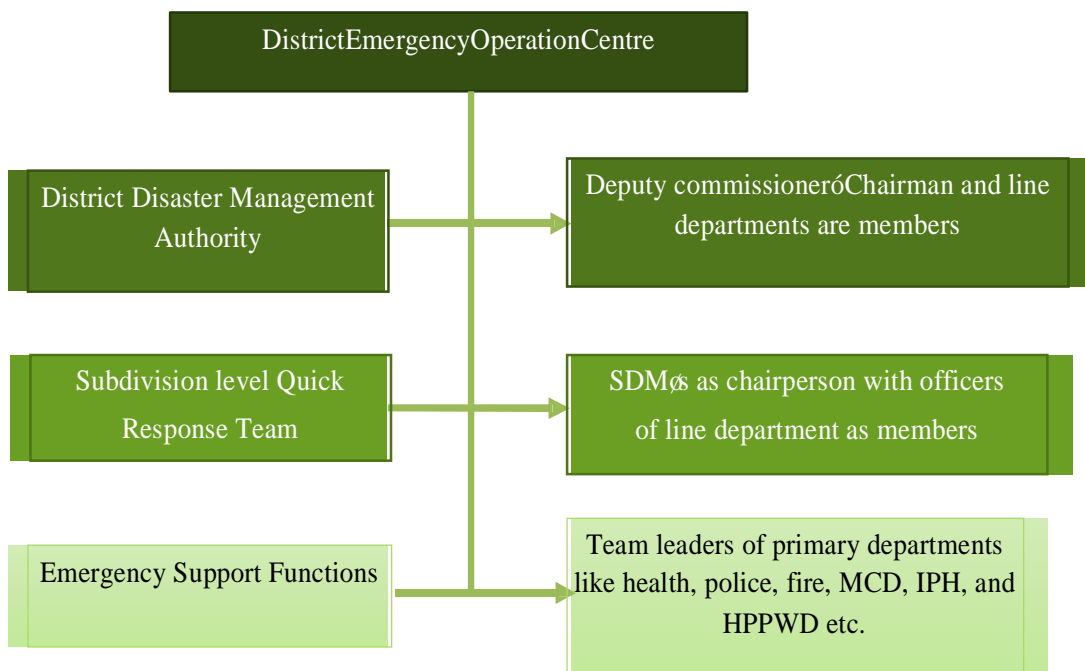

Fig 3.2: Institutional Arrangements at District Level

21. Sub-Divisional Level Mechanism in Mandi District

There shall be a Sub- Divisional Response Team at each Sub- Division. Composition of the SRT and its functions will be similar to the District Disaster Management Committee to the extent feasible. The Sub-Divisional Response Team shall consist of the following:

Members of Sub-Division Level - Disaster Management Committee

Sl. No.	Designation	Members
1.	Sub Divisional Magistrate	Chairman
2.	Block Medical Officer (Health)	Member
3.	SDPO	Member
4.	Executive Engineer, I & PH	Member
5.	Executive Engineer, HPPWD	Member
6.	Executive Engineer, (HPSEB)	Member
7.	Inspector, food Supply & Consumers	Member
8.	CDPO	Member
9.	BDOs	Member
10.	Divisional Forest officer	Member
11.	SDO (Telecommunication)	Member
12.	Tehsildar /Naib Tehsildar	Member

Non-official members:

- Pardhans Gram Panchayat / Pardhans Municipal Council / Nagar Panchayat.
- Re-preventatives of NGOs at Subdivision Level
- Elected representatives of the area
- Few prominent citizens.

All concerned Heads of the Departments shall intimate the Sub-Divisional Magistrate of each Sub-Division the name and the designation of their authorized representative and whenever there is any change of personnel. The Sub-Divisional Magistrate shall intimate the composition to the Deputy Commissioner / District Magistrate.

22. Tehsil Level Disaster Management Committee

Tehsil / Sub Tehsil level Disaster Management Committee headed by Tehsildar / Naib Tehsildar of the respective Tehsil/Sub Tehsil have been established in all Tehsils and Sub Tehsils of the District. The constitution of Tehsil / Sub Tehsil Level Committees is as under:

Members of Tehsil / Sub-Tehsil Level - Disaster Management Committee

Sl. No	Officer	Position
1.	Tehsildar/Naib Tehsildar	Chairman
2.	Medical Officer (Health)	Member
3.	SHO	Member
4.	Assistant Engineer, I & PH	Member
5.	Assistant Engineer, HPPWD	Member
6.	Assistant Engineer,(HPSEB)	Member
7.	Inspector, food Supply & Consumers Affairs	Member
8.	CDPO	Member
9.	Block Development Officer	Member

Sl. No	Officer	Position
10.	Range Forest officer	Member
11.	Sub Divisional Officer (Telecommunication)	Member
12.	Office Kanungo	Member

23. Village Disaster Management Committee (VDMC)

VDMC taking into consideration disaster at grass root level would act locally supposed to report and take assistance with Block DM Committee. Consequently, Block DM Committee would acknowledge to District DM Committee. District DM Committee will facilitate to react accordingly below level committee and share the experiences and demand fund with State Disaster Management Committee. VDMC will make block disaster preparedness and mitigation plan. Each village shall have a Disaster Management Committee consisting of officials and non-officials. The Committee will be constituted to be overseen by the Gram Sabha. The Committee will broadly be responsible for awareness generation; Warning dissemination.

Community preparedness plan. Adopting safe housing practices, organizing and cooperating relief in post disaster situations. The members are:

Sl. No.	Detail	
1	Pradhan	Chairperson
2	Panchayat Secretary	Member
3	Principal (Education)	Member
4	Health Worker	Member
5	Anganwadi Worker	Member
6	President Union / Association	Member
7	Community Representative	Member
8	Community Representative	Member
9	Community Representative	Member
10	Fair Price Shop Holder	Member

24. DISTRICT EMERGENCY OPERATION CENTRE (DEOC), MANDI

District Emergency Operation Centre (DEOC), Mandi has been established in Deputy Commissioner Office as per the directions received from Himachal Pradesh State Disaster Management Authority (HPSDMA), Shimla. The design, layout, equipment and operation of the DEOC, Mandi is as per the EOC Manual prepared at the State level. DEOC, Mandi has been equipped with all basic and advance communication and IT infrastructure e.g., EPBAX, Computers, LED sets, Telephone sets, Generator, emergency lights in ready-to-use mode. District Emergency Operation Centre (DEOC) has been established in DC office, Mandi and for the smooth running and functioning of DEOC round the clock (24x7) 08 professional have been hired.

Role of Emergency Operation Centre in Normal Time

The Deputy Commissioner of Mandi District is empowered to appoint an Administrative Officer as Officer-in-charge of EOC. He will be responsible for the effective functioning of the EOC. Responsibilities of the EOC in charge in normal time Include

- Ensure that all equipment in the EOC is in working condition.

- Collection data on routine basis from line departments for disaster management
- Develop status reports of preparedness and mitigation activities in the DDMP
- Ensure appropriate implementation of District Disaster Management Plan
- Maintenance of data bank with regular updating
- Activate the trigger mechanism on receipt of disaster warning / occurrence of disaster

Role of Emergency Operation Centre during Disaster

Based on the message received from the forecasting agencies, warning must be issued for the general public and the departments, which play a vital role during emergencies. Issuing correct and timely

warning would be one of the prime responsibilities of EOC. For effective dissemination of warning EOC should have a well- planned line of communication. The DC shall be the competent authority to disseminate a disaster warning. The warning on occurrence of a disaster will also be communicated to:

- All Emergency Support Functions
- Members of DDMC-Mandi
- Hospitals in the disaster area.
- Office of Divisional Commissioner
- State Relief Commissioner
- Emergency Operation Centre in the neighboring districts
- National / State Emergency Operation Centre
- People's representatives from the district

Apart from this the District Emergency Operation Centre must arrange desks for the Emergency Support Function in its complex for better coordination and help. Simultaneously the onsite EOCs are to be set up with the help of the district EOC. Further, the occurrence of the disaster would essentially bring into force the following:

- All district level staff from various departments, as required by the Collector, will be under the direction and control of the Responsible Officer. These would also include the district level staff.
 - Industrial Safety & Health | Health Department
 - Red Cross Society | Food & Supply | Police
 - Zila Parishad | Municipal Authorities | Public Health
 - PWD | Transport Department | Irrigation
 - Fire Department | Telecommunication
- The Responsible Officer may in case of large-scale disasters get in touch with the local Army / Navy
- / NDRF Battalion units for incidence response like rescue, evacuation and emergency relief measure.
- The Responsible Officer will have the authority to requisition resources, materials and equipment from private sector. The Responsible Officer will have power to direct the industry to activate their onsite plan and seek assistance, if required.
- The Responsible Officer will activate Response Plan with Operation Logistic and Planning Section desk arrangements and authorize establishment of transit and/or relief camps, feeding centers and cattle camps through Operation and Logistic Section.
- The Responsible Officer will send the Preliminary Information Report and Action Taken Report. In the event of possibilities of disaster in adjoining districts, including those beyond the state borders, the Responsible Officer will issue the alert warning to the concerned district authorities.

Forecasting and Early Warning Agencies

Early Warning System is the crux of disaster preparedness and response. Since, its objective is risk reduction by taking necessary precaution and action, earlier the warning is received, the better it is. For the EWS to be efficient and timely, it requires equally efficient backward linkages with instruments that become the basis for providing early warning. Apart from technological systems used for receiving early warning signal, community knowledge can also be utilized. The use of animal, birds and insects behaviors for hazard early warning is being researched even in developed countries where their behavior is associated to possibility of occurrence of disasters. Such community knowledge may be used for issuing warning message too.

Emergency Warning and Dissemination

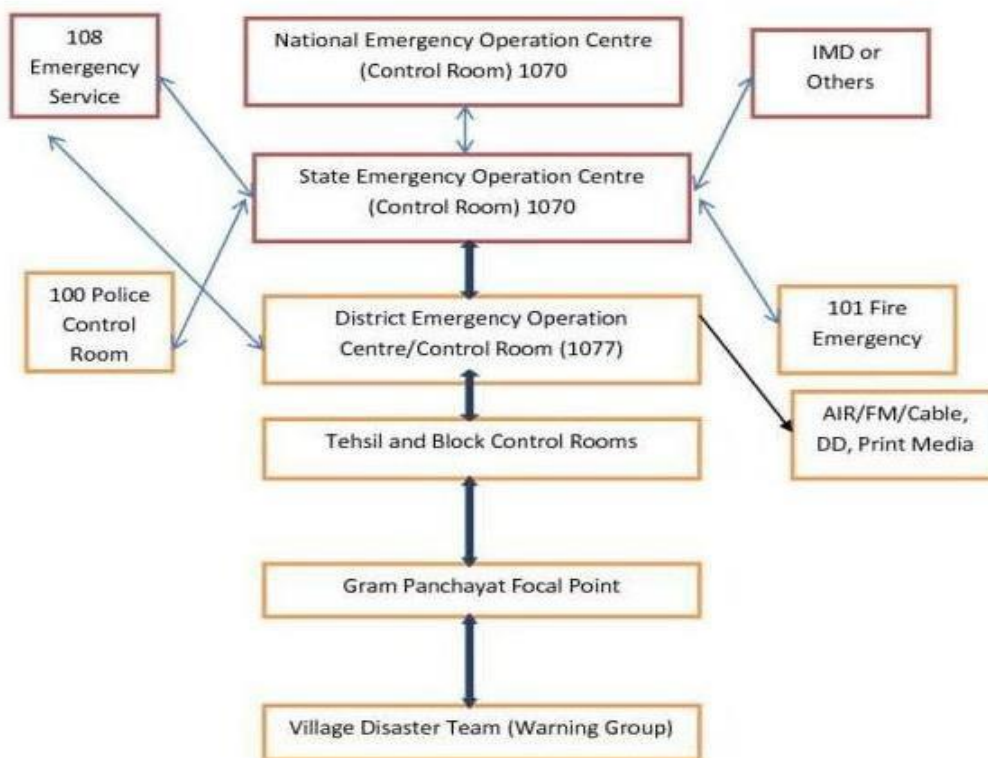

The EOC would utilize the ICT tools and various other modes available for early transmission of early warning to the vulnerable groups and activate the responders. The bulk group messaging services would also be utilized to alert the vulnerable groups and activate the SAR parties and all the responders. A model of early warning dissemination is given in figure above. The timely flow of early warning system from the source to the targeted stakeholder is important. The dissemination of early warning should be institutionalized so that it reaches the stakeholders in minimum possible time by recognized means of communication.

Following are the Nodal agencies in the Government of India and in the state mandated for early warning of different natural hazards prevailing in the state of Himachal Pradesh:

Sl. No.	Hazard	Nodal Agency with online web pages address	Contact Details
1	Floods	Central Water Commission of the Ministry of Water Resources, Shimla Zone http://india-	0183-236105 0177-2624036,0177-2624224 <i>dirmashimlacwc@nic.in</i>

Sl. No.	Hazard	Nodal Agency with online web pages address	Contact Details
		water.gov.in/ffs/ http://www.india-water.gov.in/eSWIS-MapViewer/	
2	Landslides	Geological Survey of India http://www.portal.gsi.gov.in/	0172-2622529Fax. 0172-2621945. Mob:09417371954. Joginder.singh@gsi.gov.ingsichd@sancharnet.in 1077
3	Earthquake	N-India Meteorological Department, http://www.imd.gov.in/pages/earthquake_prelim.php	N-011-24619943/ 24624588/Dehradun 0135-2525458, S-0177-2626211/0177-2629724/0177-2624976; 9816127668 mm_sandhu@yahoo.co.in D-1077,
4	Hydro-meteorological	http://www.imd.gov.in/pages/earthquake_prelim.php	
5	Droughts	http://www.imd.gov.in/pages/main.php	
6	High Wind, Hailstorm, Heat Wave, Cold Wave and High Rainfall	http://bhuvan-noeda.nrsc.gov.in/disaster/disaster/disaster.php S-SDMA/SEOC D-DDMA/DEOC	
7	Forest Fire	Forest Survey of India, Dehradun http://www.weather.shimla.gov.in/# http://fsi.nic.in/http://bhuvan-noeda.nrsc.gov.in/disaster/disaster/disaster.php?id=fire	(Fire) 01905-222900 101
8	Epidemics	Health and Family Welfare Department	CMO OFFICE:01905-222177 102&108NAS
9	Human Induced Hazards Road accidents	Himachal Pradesh Police GVK-EMRI	100 8894918180
10	Dam / Reservoir Burst	D-Hydro power project,	01905-223282 1077,01907 01902-223282

Trigger Mechanism

As soon as Emergency Operation center would get the information about any emergency, the staff on duty in EOC will pass the information the DC / RDC and seek for his instruction for further actions. If the information pertains to the occurrence of a disaster in any part of the district, the staff on duty will also try to inform DDMA members, Emergency Support Functionaries-team leaders, major Hospitals and State Disaster Management Authority etc. The staff on duty will also be responsible to reclaim information related to type, magnitude and location of the disaster and inform it to responsible authorities. The EOC in-charge will also inform all the details to Divisional Commissioner and State EOC. All the desk officers / team leaders and Incident Command Team members will also be informed to immediately report at District EOC. Incident Command team and Desk officials would respond as per their standard operating procedures and directions of Incident Commander (IC).

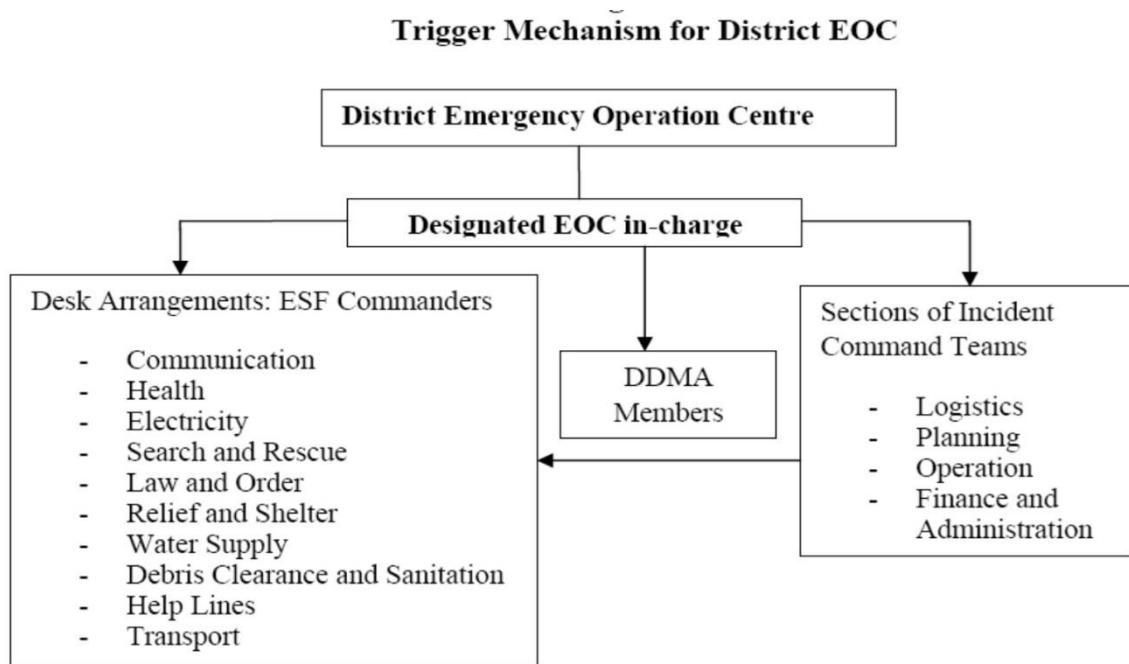

25. Incident Response System at Mandi District

The response structure would be based on Incident Response System (IRS) as per the Guidelines issued by the NDMA. IRS is a standardized method of managing disasters onsite, which is flexible and adaptable to suit any scale of natural as well as human induced disasters. It consists of common terminology, organizational flexibility, specialized training, unity, chain of command and well-rehearsed coordination mechanism. The IRS system would work through various service divisions. The IRS system would contract and expand depending upon the nature and magnitude of emergency / disaster.

At the district level, there will be one District Team with the primary function of assisting the deputy commissioner or in handling tasks like general co-ordination, distribution of relief materials, media management and the overall logistics. Suitable officers from the district administration will be carefully selected and professionally trained for the different IRS positions to constitute the District Level. The Incident Response System (IRS) at district level identifies and designates officers to perform various duties and get them trained in their respective roles; thus, reducing chaos and confusion during the response phase. It is a flexible system and all the Sections, Branches and Units need not be activated at the same time. Various Sections, Branches and Units need to be activated only as and when they are required. It also includes proper documentation of various activities for better planning, accountability and analysis which also helps new/ outside responders to immediately get a comprehensive picture of the situation and go in for immediate action. A sample IRT framework is given in figure; The DDMA would also form IRTs for all divisions and notify them. All the functionaries of IRT and IRS would be trained to understand the IRS

system. The response structure would run parallel from district based on ESF plan (Annexure) for various departments.

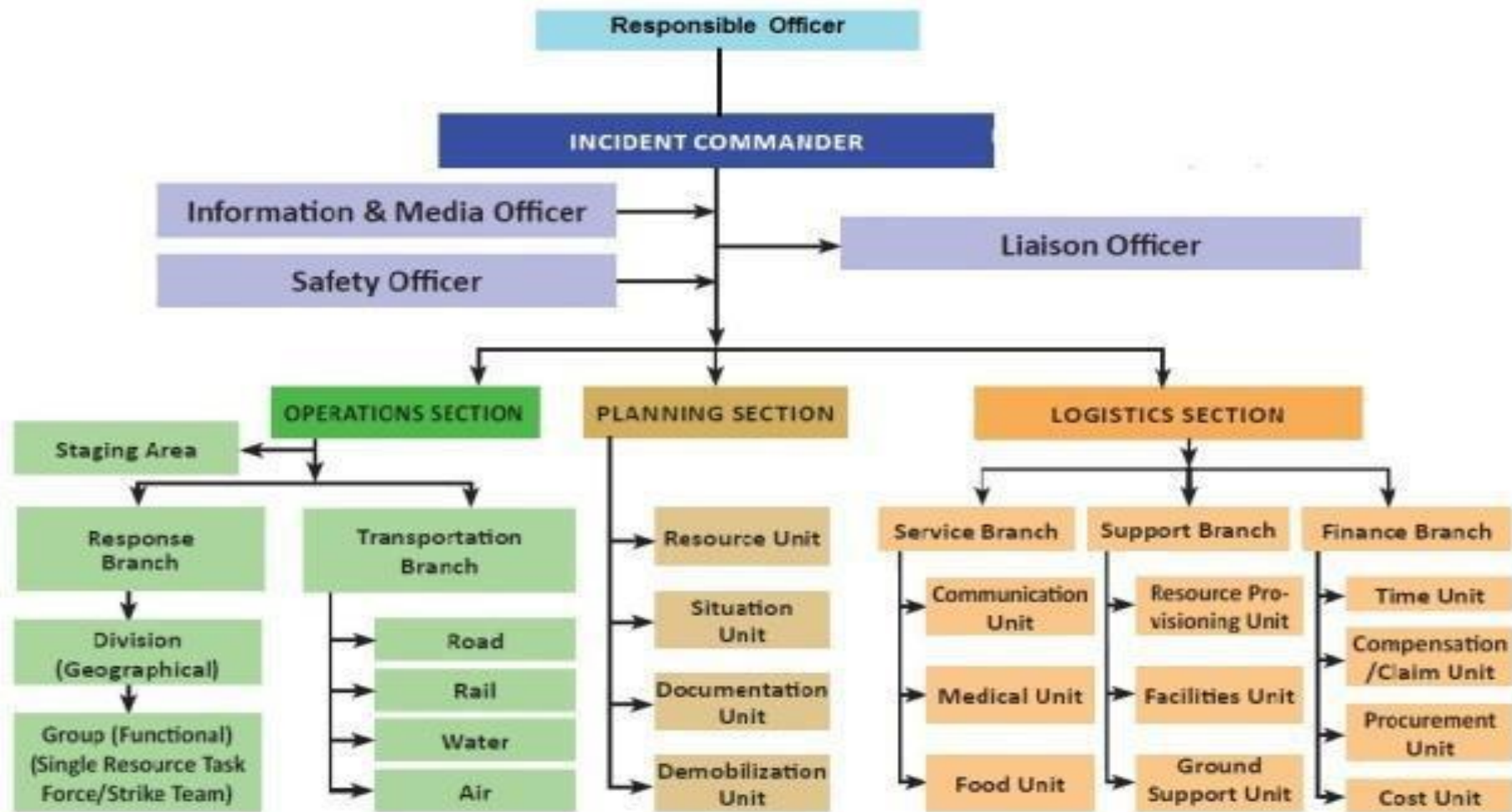

Outline of Responsibility of Main Functionary of Mandi district for IRS

Responsible Officer	Primarily responsible for effective response
Incident commander	Overall, In-charge of the Incident Response Team & its Effective Functioning.
Operations Sections	Direct & supervise all tactical actions.
Planning Sections	Collect / Analyze data, Workout need of required resources and prepare action plan for incident / Disaster of the Mandi district.
Logistics & Finance Section	Provide logistic support, procurement & cost accounting

IRS: On site Action during Disasters:

The following would be the broad guidelines for actions during disasters: -

- Assess the full extent of the disaster/calamity and the damages/losses incurred
- Plan and supervise search and rescue operations
- Allocate clear responsibilities to the officers and provide them necessary resources along with necessary delegations and Mobilize resources from outside the district if the situation so warrants.
- Finalize the relief to be provided to the affected persons and ensure its timely distribution
- Document the disaster including the lessons learnt Last but not least, keeping informing the higher authorities about the whole incident.

And all the above objectives can be achieved by Incident Response System (IRS) which is still in its infancy stag of implementation and training programs are conducted to have it streamlined in the existing administrative structure of the district.

Disaster Management and Emergency Response Plan at Project Road Level

DISASTER MANAGEMENT & EMERGENCY RESPONSE PLAN				At Project Road & Site Level
HIERARCHY ACTION IN CASE OF EMERGENCY				
Issued By	Checked By	Approved By	Date of Issue	Revision
Incident Controller/ Manager (Projects)	Site Controller/ GM (Projects)	CSC/ HPRIDC		0

IN CASE OF EMERGENCY PLEASE CONTACT



EXTERNAL AGENCY	
NAME	TELEPHONE NUMBER
Police	
Fire	
Ambulance	
Hospital(s)	
Dist. Collector Officer	
Any other agency	

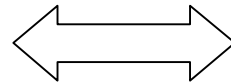

Name of the Contractor		
NAME	DESIGNATION	TELEPHONE NUMBER
	Project Manager/ Incident Controller	
	Site Controller / Emergency Controller	
	Safety In-charge / Assembly Area Coordinator	
	Security/ Watch ward	

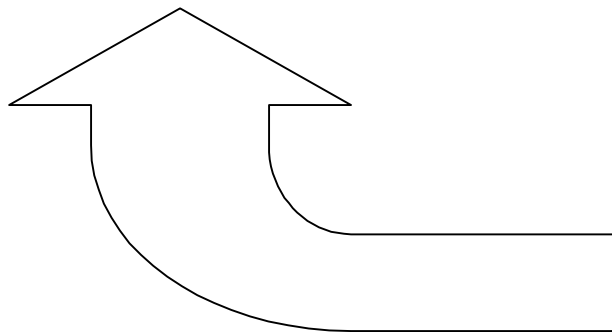

CLIENT-HPRIDC		
NAME	DESIGNATION	TEL. NUMBER
	Project Director, HPRIDC	
	Team Leader, CSC/ Resident Engineer, CSC	
	Executive Engineer. CMU	
	Environmental Specialist, HPRIDC	

Disaster Management Plan (DMP) & Emergency Preparation Plan of M/s..... (Name of the Contractor-Package Specific)

(Important Note: Needs to be updated/ prepared by the respective Contractor of the awarded package in consultation with District Disaster Management Authority, scrutinized & checked by CSC and approved by HPRIDC)

Background

The Disaster Management Act 2005 envisages disaster and its management as Disaster - Disaster means a catastrophe, mishap, calamity or grave occurrence in any area, arising from natural or manmade cause, or by accident or negligence which result in substantial loss of life or human suffering or damage to, or degradation of, environment, and is of such nature or magnitude as to be beyond the coping capacity of the community of the affected area.

Disaster Management Plan (DMP) and Emergency Preparedness Plan (EPP)

Disaster or Emergency and its Possibility

A disaster, and therefore an emergency, occurring as a result of a malfunction of the normal operating procedures or an intervention of an outside natural phenomenon force such as earthquake, floods, landslides, winds or sabotage, that may affect several sections within it and/or may cause serious injuries, loss of lives, extensive damage to property or serious disruption outside the works.

Apart from natural phenomenon, major fire and disruption, serious accidents may take place through explosion in Gas/Fuel Tankers, heavy leakage and subsequent fire in the oil tankers etc. near construction camp/ establishment sites.

Objective of Disaster Management Plan

In order to be in a state of readiness to face any accident or disaster caused during the project construction, a Disaster Management Plan shall be prepared. Such a plan ought to cover possible disaster, on and off-site emergency preparedness plan, establishment of Emergency Control Centers (ECC), location of emergency services, and duties of the officers/staff during emergency.

Basic Contents of DMP

Basically, the DMP shall contain the following aspects:

- Description of the Site
- On-site Emergency Plan
- Off-site Emergency Plan

Disaster Management - Disaster Management implies continuous and integrated process of planning, organizing, coordinating and implementing measures which are necessary as expedient for

- Prevention of danger or threat to any disaster.
- Mitigation or reduction of risk of any disaster or its severity or consequences.
- Capacity building.
- Preparedness to deal with any disaster.
- Prompt response to any threatening disaster situation or disaster.
- Assessing the severity of magnitude of effect of every disaster.

- Evacuation rescue & relief.
- Rehabilitation and reconstruction.

BASIC DEFINITIONS

1. **On-Site Plans** - address incidents originating at any of construction/ operation sites or establishment sites
2. **Off-Site Plans** - address incidents originating at any of construction/ operation sites or establishment sites outside but affecting the Project Work
3. **Risk**-The chance of an adverse event occurring in some period or in a specific circumstance, in the process of engaging in an activity
4. **Hazard**-
A phenomenon which may cause disruption to persons and their infrastructure; and is an undesirable outcome in the process of engaging in an activity
5. **Disaster** - An event which can cause immense damage and disruption and causing loss to lives of workforce and property.
6. **Emergency**-
Serious sudden situation or occurrence that happens unexpectedly and demands immediate action to correct or to protect lives and/or property.
7. **Crisis**-Unstable situation of extreme danger and may lead to the following elements:- Surprise-- Rapid flow of events- Lack of or insufficient information- Internal conflict- confusion
8. **Disaster Management**-Set of actions and processes designed to lessen disaster effects before, during and after a disaster.
9. **Preparedness**-
Measures undertaken in advance to ensure that individuals and agencies will be ready to react, such as emergency plans, logistical support and resource, inventories, and emergency information & communication systems
10. **Response**-
Those measures undertaken immediately after a disastrous or hazardous event has occurred and for a limited period thereafter, primarily to save human life, property, treating the injured, prevent further injury and other forms of property loss and to mitigate disruption. They include response plan activation, declaration and communication of emergency to the concerned potential population and facilities at risk, opening and staffing of emergency operation centers, mobilization of resources, issuance of warnings and directions and provision of aid.
11. **Mitigation**-Those measures and activities aimed at reducing or eliminating hazards or lessening the impact of the event.
12. **Prevention**-Mitigation of hazard effects through public education, early warning or detection systems, safety systems, building and land-use codes and regulation.
13. **Recovery**-
Those measures undertaken to restore normal conditions. The time frame for recovery begins as soon as a reduction in critical response activities permits the allocation of resources and could include physical restoration and reconstruction.
14. **All Clear**-Direction given by

the incident coordinator (or authorized person) that the emergency has been revoked and that there is no further damage.

15. **Assembly Areas**—On decision of evacuation, the place where people will move first to assembly area where further instruction will be given.

16. **Suspect Device**—

Any item that contains an explosive or mechanical device designed to explode by means of timer, touching, impact or by remote control as suspect device may appear suspicious by its placement, the circumstances surrounding its location or other information that may cause any person to become suspicious and decide that further investigation is necessary.

Key Objectives of the Plan

- To build a safe and disaster resilient project construction sites by developing
- a holistic,
- proactive,
- multi-disaster oriented and
- technology driven strategy through
- prevention,
- mitigation,
- preparedness and
- response

Objective of Disaster Management Plan

- To improve state of preparedness to meet any contingency
- To reduce response time in organizing assistance by
- defining responsibilities,
- procedures for facilitating the curtailment and/ or restoration of Asset(s).
- To identify
- major resources,
- manpower, material & equipment needed to make the plan operational
- Making optimum use of resources.
- Closure of emergency, its analysis and identification of lessons learnt

Scope of Disaster Management Plan

- Landslides
- Floods
- earthquake
- Cloud burst
- Fire
- Terrorist Attack
- Any other hazard

Prevention of Disasters

Design the system after considering factors like:

- Highest flood level
- Seismic zones
- Wind zones
- Fire protection system
- Physical Security arrangements
- Other critical parameter

Disaster Management Cell at Contractor

- Management level at Contractor's Corporate Office
- Site level at respective project sites

Site level Disaster Management Committee

- Site Manager
- Site Engineers
- Safety In charge

Disaster Management at Site Level Responsibilities

- To maintain and update emergency call out list of persons:
 - for emergency control,
 - key personnel of Client
 - fire safety
 - first aid, medical emergencies
 - Security, Police, District Administration Authorities
- Display communication details of nodal officers to be contacted in emergency
- Fixing of permanent notice boards at all suitable locations at project operation/ establishment sites displaying information, map, escape routes, precautions to be taken during emergency.
- To arrange food, drinking water, Tent for office space at site, accommodation for deployed employees/ workers (all levels)

Appointment of Key Persons and their Role at Project Road/ Site Level

1. Site Controller (SC)

The General Manager (however called) or his nominated deputy will assume overall responsibility for the Site and its personnel.

2. Incident Controller (IC)

Project Manager or an Officer of similar rank will be nominated to act as the IC. Immediately on learning about an emergency, he will rush to the incident site and take overall charge and report to the SC.

3. Liaison Officer (LO)

Personnel/ Administrative Manager or his nominated Officer of deputy rank will work as LO and will be stationed at the Nodal Control Centers during emergency to handle Police, District Administration,

Hospitals and other enquiries.

4. Forward Area Controller (FAC)

Departmental Incharge of the concerned area will be the FAC to take care of the respective departments during emergency.

5. Task Specific Team Leaders (TLs)

A number of specified activities may have to be carried out, for which specific teams have to be formulated and their roles or duties defined, each of them will be headed by a Team Leader, in accordance. The following teams are suggested:

- Task Force
- Repair Team
- Fire Fighting Team
- Communication Team
- Security Team
- Manpower Team
- Safety Team
- Transport Team
- Medical Team

Emergency Control Centers (ECC)

Emergency Control Room is to be set up and marked on the site plan for the knowledge of all concerned. EC is the focal point and it should be well connected with internal and external telephones and furnished with list of personnel and their addresses.

Assembly Points

Assembly points, the pre-determined safe places, where people will be directed after reevaluation from the hazardous locality, have to be set up and marked on the site plan. Escaper routes from assembly points have to be clearly defined and depicted.

Alarms

Suitable sirens will be provided at Site, which could be operated from the Nodal Control Rooms. The coding of the siren should be as per the standards and well circulated within the facility.

Tie Ups for Aid with Institutions (Hospitals, Wards, Police Stations etc.)

It is essential to have mutual aid arrangements among the industries in the neighborhood which would help in the case of a major disaster.

Training and Mock Drills

Proper training of the key personnel and other non-key personnel, who will take part in case of an emergency, should be arranged through engagement of district level disaster management authorities. Mock drills shall be performed to test the performance of the procedure laid

Emergency Callout List

Sl. No.	Name of Official/Agency	Mobile No.	Landline No.	Address
1	Site Manger			
2	Site Engineer			
3	Safety In charge			
4	Team Leader, CSC			
5	Resident Engineer, CSC			
6	Executive Engineer, CMU			
7	Environmental Specialist HPRIDC			
8	Project Director, HPRIDC			
9	Nearest Fire Station-I			
10	Nearest Fire Station-II			
11	Nearest Hospital-I			
12	Nearest Hospital-II			
13	Police Station			
14	District Magistrate			
15	Superintendent of Police			
16	District Disaster Management Cell			
17	State Disaster Management Cell			
18	National Disaster Management Cell			

APPENDIX-18: ILLUSTRATIVE CHECKLIST FOR WORK ZONE SAFETY REQUIREMENTS

Avoiding Collisions [Runovers & Backovers]

Safety & Health Checklist for the Roadway Construction Industry

How are most roadway construction workers killed?

Over 40% — nearly half — of the fatalities for roadway construction workers occur when workers are run over or struck by moving vehicles, trucks or equipment. Over half of the fatalities are caused by construction vehicles and equipment in the work area.

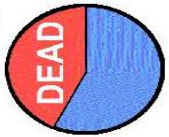

How can you avoid a "collision" in your work area?

Be seen. Make sure you wear high visibility clothing, including a vest and hard hat.



Communicate. If you are working near construction vehicles and equipment, make sure the operator/ driver knows where you are located. DO NOT assume he/she can see you.

Stay back. Do not approach moving equipment. Communicate with the driver using a radio, hand signals, etc. Only approach the vehicle once the operator has stopped operations.



Plan. Set up a plan or procedure — some call it an "internal traffic control plan" — to separate workers from the paths of vehicles and equipment. Make sure vehicles know where workers are located and workers know where equipment is operating.

Look out for other workers. Use a whistle, air-horn, or other device to warn fellow workers when they are in danger.



Positive Separation. Separate workers from traffic using "positive separation," such as barriers, road closures, shadow vehicles, and

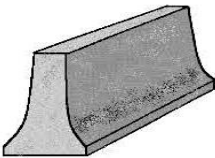

buffer space. Remember, this separation is important for BOTH roadway traffic and construction vehicles.

- ❑ **Be alert.** Don't become complacent with your work environment. Stay alert at all times and in all places. Stop, look, and listen for possible hazards.

Flaggers and directing traffic

Each year about 20 flaggers are killed and many more are injured. Flaggers must be especially vigilant to protect against collisions.



- ❑ **Get trained.** Don't accept an assignment to be a flagger unless you have been properly trained. You must know where to stand, how to dress, and how to properly communicate with motorists.
- ❑ **Wear high visibility clothing.** Know what type of clothing you should wear depending on the speed of traffic, the time of day, and the complexity of your surroundings.

- ❑ **Stay focused.** Keep your eyes on oncoming traffic. Make sure your signals are clear and do not conflict with other traffic control signals.



- ❑ **Plan an escape.** Plan a route so you can move quickly to safety if a motorist does not appear to heed your signals.
- ❑ **Warn fellow workers.** Make sure you have a way to quickly warn other workers when vehicles do not respond to your signals.

- ❑ **Respect motorists.** Be courteous. Do not respond to abusive drivers. Notify law enforcement if necessary.



This material was produced under grant number 46C3-HT31 from the Occupational Safety and Health Administration, U.S. Department of Labor. It does not necessarily reflect the views or policies of the U.S. Department of Labor, nor does mention of trade names, commercial products or organizations imply endorsement by the U.S. Government. The developers have not assumed any part of the employer's exclusive responsibility to provide a safe & healthful work place. **To find more information, please visit: www.artba.org or <http://wzsafety.tamu.edu>.**

Electrical Hazards

Safety & Health Checklist for the Roadway Construction Industry

What are volts, ohms, amps, and current?

- ❑ **Voltage** = force or pressure that causes electricity to flow through a conductor (wire). (Think of water held behind a dam.)
- ❑ **Ohm = resistance** that impedes the flow of electricity through a conductor. (Think of pipes. Pipe size restricts water flow.)
- ❑ **Amp** = measurement of **current** — the flow of electrons — from the source of voltage through a conductor. (Think of water moving through a pipe.)

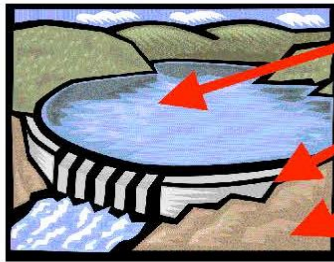

Voltage is like water in a reservoir. It's the measurement of electrical pressure.

Ohm is like water in a pipe. It's the measurement of electrical resistance.

Amp is like water moving through a pipe. It's the measurement of electrical movement or "current."

How much electricity will hurt me and how?

For death to occur, the body must become part of an electrical circuit. The actual amount of damage depends on the amount of current (amps), the pathway of electricity as it passes through the body, and the duration of the event.

Estimated Effects of AC Currents (U.S. Standard 60 Hz)	
1 millamp (mA)	Barely perceptible
16 mA	Maximum current an average man can grasp and "let go"
20-30 mA	Paralysis of respiratory muscles
100 mA	Ventricular fibrillation threshold
2 Amps	Cardiac standstill and internal organ damage
15/20/30 Amps	Common U.S. household breakers



Check for these common sources of electrical energy exposure:

- Worn power cords (extension cords, hand tools)
- Water on or near electrical outlets, tools & cords
- Temporary circuit boxes and breakers for construction job sites
- Switches and connections on equipment, vehicles and machinery
- Buried utilities
- Overhead power lines

What are some precautions you can take to avoid contact with electrical energy:

- Contact appropriate "one call" number.
- Ensure buried utilities are marked by the proper authority.
- Locate and mark overhead power sources. Develop protocols for working near overhead power lines.
- De-energize, lockout and tagout power sources for equipment, tools and machinery before repairing or servicing.
- Use "ground fault circuit interrupters" (GFCIs) on all power tools and equipment that are not double-insulated.
- Inspect tools, cords, etc. to ensure they are in good condition before each use.
- Use appropriate personal protective equipment (PPE) including:
 - o Insulated gloves and footwear
 - o Non-metallic ladders

This material was produced under grant number 46C3-HT31 from the Occupational Safety and Health Administration, U.S. Department of Labor. It does not necessarily reflect the views or policies of the U.S. Department of Labor, nor does mention of trade names, commercial products or organizations imply endorsement by the U.S. Government. The developers have not assumed any part of the employer's exclusive responsibility to provide a safe & healthful work place. **To find more information, please visit:** www.artba.org or <http://wzsafety.tamu.edu>.

Mechanized Equipment

Safety & Health Checklist for the Roadway Construction Industry

What hazards are created by construction vehicles and equipment?

Construction vehicles and motorized equipment present a major hazard to highway construction workers. Recent studies indicate that workers are killed just as often by vehicles and equipment operating within the work zone as by motorists that cross the barricades and strike workers.

Construction vehicles and equipment can endanger:

- Drivers and operators
- Workers on foot
- Motorists/ public

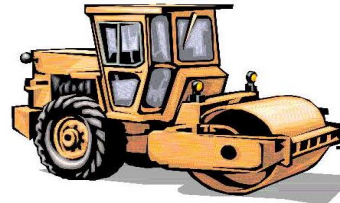

To avoid roll-over hazards, DO NOT:

- Operate equipment too fast or on a steep grade
- Exceed the manufacturer's load or operating limits
- Use inadequate methods to load machinery onto a transport trailer
- Set, park or operate equipment on soft spots/soft shoulders
- Fail to use seatbelts, if equipped, to remain in position to control the vehicle



To avoid striking pedestrian workers with the vehicle, or its equipment — such as a bucket or shovel — check to ensure it has:

- Adequate brakes
- Functioning backup alarm
- Known blind spots (operators must check around their vehicle for workers before engaging)
- Proper barricades protecting the swing area of the equipment
- Continuous communication with pedestrian workers



Common hazards for equipment operators include striking utilities. Operators must have proper training and ensure adequate clearance. Construction vehicles and equipment can endanger workers by:

- Knocking down overhead wires or tree branches
- Making contact with power lines or buried utilities, causing the equipment to become energized
- Operating with an unguarded/ unbarricaded blade, swing radius and/or scissor points.



How can operators reduce hazards to themselves?

- Install and use rollover protective structures (ROPS)
- Install and use seat belts that meet the Society of Automotive Engineers (SAE) requirements
- Maintain a safe speed
- Use spotters for backing, loading, etc.
- Use ramps that are the right size and stable
- Use painted guidelines or other markings to guide operators and indicate hazardous areas



How can you prevent injuries to workers on foot?

- Inspect brakes and other stopping devices to ensure they are operating properly and able to stop and hold equipment when fully loaded
- Check to ensure backup alarms work and are louder than surrounding noise
- Use mirrors, closed circuit television, sensors and alarms or spotters to look for workers and hazards
- Make certain cab glass is not dirty, cracked or broken, and does not distort the operator's view
- Have operators check for other workers before starting the machine
- Warn workers when vehicles or equipment with rotating cabs are in use
- Guard scissor points, pinch points, and the swing radius of equipment when necessary

This material was produced under grant number 46C3-HT31 from the Occupational Safety and Health Administration, U.S. Department of Labor. It does not necessarily reflect the views or policies of the U.S. Department of Labor, nor does mention of trade names, commercial products or organizations imply endorsement by the U.S. Government. The developers have not assumed any part of the employer's exclusive responsibility to provide a safe & healthful work place. **To find more information, please visit: www.artba.org or <http://wzsafety.tamu.edu>.**

High Visibility Clothing

Safety & Health Checklist for the Roadway Construction Industry

What is "high visibility" clothing and when do you need it?

High visibility clothing refers to reflective and fluorescent vests, shirts, pants, hats, etc. that workers should wear to make them more visible when working near traffic and heavy equipment, in all light conditions, day and night.



You should wear high visibility clothing if:

- You work near traffic (on the side of a roadway, as a flagger, directing traffic, etc.).
- You work near moving construction vehicles and equipment such as large vehicles, dump trucks, pavers, graders, etc.

What type of clothing should you wear?

There are different classes of clothing, depending upon the hazards you are likely to face.

- Class 1 garments:** For workers that are separated from vehicular traffic that does not exceed 25 mph; where background settings and worker tasks are not complex.



- Class 2 garments:** Necessary for greater visibility during inclement weather; where work background is more complex and is close to moving traffic and vehicles; workers' attention will likely be diverted from traffic traveling at speeds from 25-50 mph.



- **Class 3 garments:** Traffic speed is greater than 50 mph; worker must be conspicuous — and identifiable as a person — through the full range of body motions at a minimum of 1,280 feet.

Is high visibility clothing hot and uncomfortable?

When the ANSI/ISEA 107 Standard for High Visibility Apparel was first developed, some of the early designs were hotter than what road-way construction workers were used to wearing.



Over the past few years, new designs have been developed, made of light-weight, breathable fabrics that are much cooler and can be comfortably used in hot and humid weather.

To obtain more information about the ANSI/ISEA 107 standard or to order a copy of High Visibility Apparel, contact the International Safety Equipment Association (ISEA) at www.safetysafetyequipment.org.

This material was produced under grant number 46C3-HT31 from the Occupational Safety and Health Administration, U.S. Department of Labor. It does not necessarily reflect the views or policies of the U.S. Department of Labor, nor does mention of trade names, commercial products or organizations imply endorsement by the U.S. Government. The developers have not assumed any part of the employer's exclusive responsibility to provide a safe & healthful work place. **To find more information, please visit: www.artba.org or <http://wzsafety.tamu.edu>.**

Multi-Employer Policy

Safety & Health Checklist for the Roadway Construction Industry

Are you covered by OSHA's Multi-Employer Policy?

You may be responsible for activities of other employers on the job site that expose workers to safety and health hazards.

Is there more than one employer / contractor on your site? If yes, then continue.

Did your company create and expose your workers OR the workers of another employer to hazards?

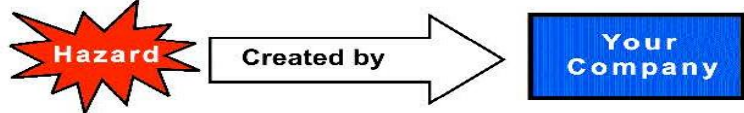

Is your company responsible, by contract or actual practice, for the safety and health conditions on a work site (even if none of your workers are exposed or your company did not create the hazard)?

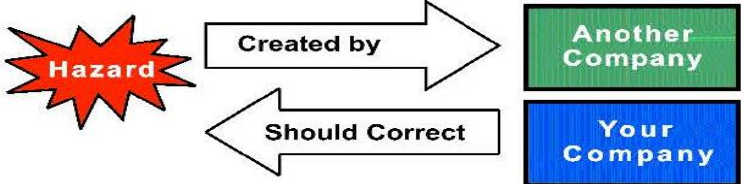

Does your company have the responsibility for actually correcting the hazard (even if none of your workers are exposed or your company did not create the hazard)?

Are your workers exposed to a hazard that was created by another employer?

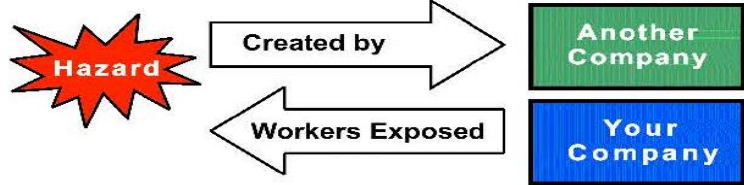

If you checked any of the boxes on the front, YOU MAY BE SUBJECT TO A CITATION FROM OSHA THROUGH THE MULTI-EMPLOYER POLICY.

Before OSHA issues a citation, it will consider the following issues that may reduce an employer's liability:

Did your company create the hazard?

Did your company have the responsibility or authority to correct the hazard?

Did your company have the ability to correct or remove the hazard?

Did your company notify the other responsible employers about the hazard to which their employees were exposed?

Did your company instruct its employees to recognize the hazard and 1) take steps to remove its employees from exposure, or 2) in extreme cases, remove its employees from the job?

What do you do when you find a hazard on your job site?

Correct or remove the hazard. If you are unable to do so, then:

Notify your workers and other employers of the hazard, and

Remove your workers from exposure to the hazard, or

Remove your workers from the job site.

NO MATTER WHAT OTHER EMPLOYERS OR WORKERS MAY DO, YOU ARE ULTIMATELY RESPONSIBLE FOR THE SAFETY AND HEALTH OF YOUR WORKERS.

This material was produced under grant number 46C3-HT31 from the Occupational Safety and Health Administration, U.S. Department of Labor. It does not necessarily reflect the views or policies of the U.S. Department of Labor, nor does mention of trade names, commercial products or organizations imply endorsement by the U.S. Government. The developers have not assumed any part of the employer's exclusive responsibility to provide a safe & healthful work place. **To find more information, please visit:**
www.artba.org or <http://wzsafety.tamu.edu>.

Night Work

Safety & Health Checklist for the Roadway Construction Industry

What are some of the common problems identified with night work zones?

- Reduced visibility
- Driver impairment or inattention (drugs, alcohol)
- Fatigue, sleepy drivers
- Inadequate lighting
- Poor maintenance of traffic control devices



What are some of the solutions to the problems of night work?

- Have police officers present and visible
- Make workers more visible (better garments and lighting)
- Use drums in the taper
- Keep traffic control devices in good condition
- Provide adequate lighting
- Space traffic control devices closer together to reduce confusion — especially on ramps, crossovers, etc.



What can be done to reduce hazards for drivers?

- Use changeable message signs with up-to-date information.
- Obtain assistance from law enforcement. Ensure that all signs, markings, channelizing devices, and barricades are in good condition.
- Remove devices that are dirty, disfigured, or are not retroreflective.
- Use good quality temporary pavement markings. Cover or remove old, confusing markings.
- Increase the length of tapers to facilitate merges.
- Use transitional lighting to avoid temporary blindness from abrupt transitions from darkness to bright light and from bright light to darkness.
- Ensure that temporary work lighting does not glare in the eyes or mirrors of passing motorists.
- Move signage along with the work zone.

**ROAD WORK
AHEAD**



Does night work increase health problems?

Working at night makes it difficult to get enough sleep. Sleep after night work usually is shorter and less refreshing or satisfying than sleep during the normal nighttime hours.



Some research suggests that night workers have more upset stomachs, constipation, and stomach ulcers than day workers.

How can you protect your health and safety when working at night?

- Avoid permanent (fixed or non-rotating) night shifts.
- Keep consecutive night shifts to a minimum.
- Avoid quick shift changes.
- Plan some free weekends.
- Avoid several days of work followed by four to seven day "mini-vacations."
- Keep long work shifts and overtime to a minimum.
- Consider different lengths for shifts.
- Examine start-end times.
- Keep the schedule regular and predictable.
- Consider taking more frequent rest breaks.

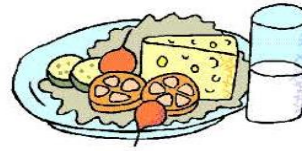

How can you maintain an active family and social life?

- Schedule activities on weekends or "off-days" to be with family and friends.
- Plan one meal a day when the family can eat together.
- Schedule "quiet" time during the day when you can get adequate, uninterrupted sleep.
- Don't participate in too many activities or other work that prevents you from getting adequate rest.
- Maintain a healthy diet and find time to exercise.



This material was produced under grant number 46C3-HT31 from the Occupational Safety and Health Administration, U.S. Department of Labor. It does not necessarily reflect the views or policies of the U.S. Department of Labor, nor does mention of trade names, commercial products or organizations imply endorsement by the U.S. Government. The developers have not assumed any part of the employer's exclusive responsibility to provide a safe & healthful work place. **To find more information, please visit:**
www.artba.org or <http://wzsafety.tamu.edu>.

Personal Protective Equipment

Safety & Health Checklist for the Roadway Construction Industry

What is Personal Protective Equipment?

Hard hats, safety glasses, face shields, earplugs, fall arrest systems, safety-toed shoes, and respirators are all types of *personal protective equipment* or PPE.

In the roadway construction industry, there are many potential hazards you might face every day. Your use of PPE is very important to protect your safety, health, and even life.



Who should provide your PPE?

It is the employer's duty to make sure you have the necessary equipment to safely do your work. In some cases, if the PPE could likely be used away from work, you may be required to purchase your own. The items you may have to purchase are apparel such as safety-toed shoes, prescription safety glasses and outerwear.

What types of PPE should you use?

The best way to protect against hazards is to eliminate them, such as providing guardrails to prevent falls, or good ventilation to remove fumes and gases.

In roadway construction, these "engineered" hazard controls are not always feasible, so PPE must be worn to protect against the hazards to which you are exposed on any given task.

Here are some of the basics:

- Hard Hats** (head protection): Protect against electrical shock and impacts caused by falling objects or rocks thrown by passing vehicles. May provide for increased visibility near traffic and large vehicles.
- Safety Glasses** (eye and face protection): Protect against chemicals, particles, dust, and other airborne substances. Some safety glasses protect against the bright sun and provide UV protection for the eyes.



- ❑ **Gloves** (hand & arm protection): Protect against burns caused by electrical hazards, hot materials (asphalt), caustic materials (wet cement), and provide protection against cuts, punctures, blisters and skin irritation.

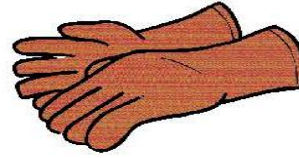

- ❑ **Ear plugs/muffs** (hearing protection): Protect against hearing loss that may occur suddenly, or gradually over time due to exposures to loud noises, such as heavy equipment or noisy hand tools.



- ❑ **Safety-toed shoes** (foot and leg protection): Provide protection against sharp, falling or rolling objects, hot materials, and slippery surfaces.

- ❑ **Harnesses and lanyards** (fall protection): Protect workers from falling. Required for exposures at six feet or higher, such as bridge construction, form work, overpasses, etc.



- ❑ **Respiratory protection** (dust mask / respirator): This type of protection can be a bit complicated, and will require competent personnel to determine what type of protection is needed and proper fit. You may need protection if you are working with or in proximity to:

- o dust containing silica (concrete & asphalt cutting, rock crushing, sand blasting)
- o metal fumes (from welding, brazing, soldering)
- o chemical fumes (motor fuels, cleaners, petroleum-based products)

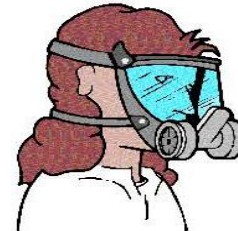

To obtain more information about personal protective equipment, contact the International Safety Equipment Association (ISEA) at www.safetysafetyequipment.org.

This material was produced under grant number 46C3-HT31 from the Occupational Safety and Health Administration, U.S. Department of Labor. It does not necessarily reflect the views or policies of the U.S. Department of Labor, nor does mention of trade names, commercial products or organizations imply endorsement by the U.S. Government. The developers have not assumed any part of the employer's exclusive responsibility to provide a safe & healthful work place. **To find more information, please visit:** www.artba.org or <http://wzsafety.tamu.edu>.

Temporary Traffic Control Zones

Safety & Health Checklist for the Roadway Construction Industry

What is a "Temporary Traffic Control Zone" or "Work Zone"?

A temporary traffic control zone, commonly known as a work zone, is the area on a roadway where construction work is taking place adjacent to traffic. Because of the constraints and locations of most work zones, they can pose many hazards for workers and motorists.

For definition purposes, a work zone has the following parts: 1) Advance Warning Area, 2) Transition Area, 3) Activity Area (Work Space, Traffic Space and Buffer Space), and 4) Termination Area.

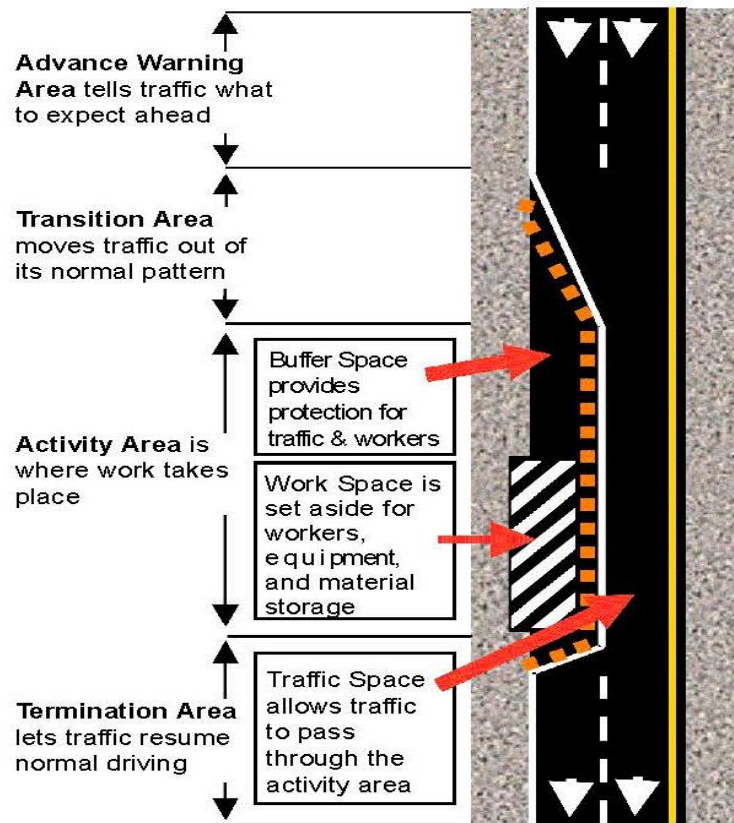

Review the following items to help you determine if your work zone is set up properly:

- Is the work zone set up as designed in the Traffic Control Plan? OR, if it is a small job where a traffic control plan was not developed . . .
- Are the traffic control devices (signs, markings, cones, barrels, etc.) set up as specified in the *Manual on Uniform Traffic Control Devices*?
- Are your signs in good condition? Do they maintain their "retroreflective" properties?
- Are your advance warning signs placed at the proper distances to adequately warn drivers?
- Are your channelizing devices (cones, barrels, barriers, etc.) placed properly, spaced at the proper distance according to traffic speeds?
- Are your channelizing devices in good condition? Do they maintain their "retroreflective" properties?
- Have old pavement markings been completely removed, and are new, clear temporary markings in place?
- Does your work zone traffic control require a flagger?
- Has your flagger been trained in a recognized program?
- Is your flagger attentive, always facing oncoming traffic, standing in the proper location, and using the correct signals/ paddle to direct traffic?
- Is your flagger properly dressed, with appropriate clothes to make him or her visible to traffic and construction vehicle operators?
- Does your flagger have a way to communicate with the other workers on the site?

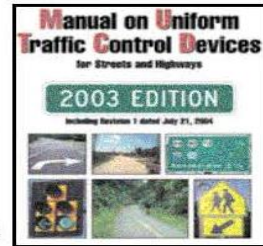

This material was produced under grant number 46C3-HT31 from the Occupational Safety and Health Administration, U.S. Department of Labor. It does not necessarily reflect the views or policies of the U.S. Department of Labor, nor does mention of trade names, commercial products or organizations imply endorsement by the U.S. Government. The developers have not assumed any part of the employer's exclusive responsibility to provide a safe & healthful work place. **To find more information, please visit: www.artba.org or <http://wzsafety.tamu.edu>.**