

Himachal Pradesh State Roads Transformation Program (HPSRTP)

(Under Funding Assistance of the World Bank)

Raghunathpura- Mandi – Harpura - Bharari
(Km 0.00 to 2.74)

Environment and Social Management Plan (Final) APPENDICES Volume

October 2021

Report Prepared by:

Deccan Consulting Engineers Private Limited, New Delhi
(Independent ESIA Consultant to HPRIDCL)



**HIMACHAL PRADESH ROAD & INFRASTRUCTURE
DEVELOPMENT CORPORATION LIMITED**
(Government of Himachal Pradesh Undertaking)
(An ISO 9001:2008 QMS & ISO 14001:2004 EMS conforming company)

LIST OF APPENDICES

APPENDIX 1: BORROW AREAS MANAGEMENT PLAN	1
APPENDIX 2: QUARRY MATERIALS	5
APPENDIX 3: GENERAL GUIDELINES FOR CONTRACTOR'S CONSTRUCTION WATER MANAGEMENT PLAN	7
APPENDIX 4: SELECTION AND MANAGEMENT OF CONSTRUCTION CAMP.....	9
APPENDIX 5: DEBRIS DISPOSAL SITE MANAGEMENT	12
APPENDIX 6: TRAFFIC AND SAFETY MANAGEMENT DURING CONSTRUCTION.....	14
APPENDIX 7: FORMATS FOR ENVIRONMENTAL REPORTING	17
APPENDIX 8: NATIONAL STANDARDS OF AIR, NOISE, WATER AND SOIL	35
APPENDIX 9: ENVIRONMENT FRIENDLY CONSTRUCTION METHODOLOGY	37
APPENDIX 10: SOIL EROSION AND SEDIMENTATION CONTROL.....	42
APPENDIX 11: WORKERS SAFETY IN COMMON OPERATION AND DURING CONSTRUCTIONS	43
APPENDIX 12: STORAGE HANDLING, USE AND EMERGENCY RESPONSE FOR HAZARDOUS CHEMICALS	55
APPENDIX 13: ENVIRONMENT COMPLIANCE CERTIFICATE	58
APPENDIX 14: SEPTIC TANK AND OIL INTERCEPTOR	60
APPENDIX 15: MANAGEMENT PLAN FOR LABOUR INFLUX.....	62
APPENDIX 16: GOHP'S STRATEGY TO REHABILITATE AREAS INFESTED WITH INVASIVE ALIEN PLANT SPECIES (EXOTIC WEEDS) IN HIMACHAL PRADESH	68
APPENDIX 17: DISASTER MANAGEMENT & EMERGENCY RESPONSE PLAN AT PROJECT ROAD LEVEL.....	75
APPENDIX 18: ILLUSTRATIVE CHECKLIST FOR WORK ZONE SAFETY REQUIREMENTS	108

APPENDIX 1: BORROW AREAS MANAGEMENT PLAN

Embankment fill material is to be procured from borrow areas designated for the purpose. The properties of the borrow material shall be got tested and recorded. Borrow area management plan pertains to the measures that need to be incorporated during identification of borrow area location, material extraction and rehabilitation.

If required, borrow areas will be identified by the Contractor and after identification site specific details (including revenue record, rehabilitation plan and agreement with owner) will be submitted to PMC for approval. Once approved, Contractor would require operating and closing the site as per EMP reporting formats.

The contractor in addition to the established practices, rules and regulation will also consider following criteria before finalizing the locations. During design stage of the project, following borrow areas have been identified.

- i) The borrow area should not be in agriculture field unless unavoidable i.e. barren land is not available.
- ii) The borrow pits should not be located along the roads.
- iii) The loss of productive and agriculture soil should be minimum.
- iv) The loss of vegetation is almost nil or minimum.
- v) Sufficient quality of soil is available.
- vi) The Contractor will ensure that suitable earth is available.

The Contractor shall obtain representative samples from each of the identified borrow areas and have these tested at the site laboratory following a testing programme approved by the PMC.

Though, reuse of excavated material will be done for filling up of embankments or other such requirements, but in case of lack of suitable material following locations have been identified, which can be used as borrow areas by contractor after taking approval from owner and other authorities as required.

Identified borrow areas along the Project Road

BA. No.	Chainage (km)	Lead (m)	Side (LHS/RHS)	Ownership Details	Available Quantity
BA-1	0+480	20	RHS	Government	Hill (Adequate)

No borrow area shall be operated without permission of the Engineer. The procurement of borrow material should be in conformity to the guidelines laid down in IRC:10-1961. In addition, the contractor should adopt the following precautionary measures to minimize any adverse impacts on the environment:

- I. The unpaved surfaces used for haulage of borrow materials will be maintained dust free by the contractor through sprinkling of water twice a day during the period of use.
- II. To avoid any embankment slippage, the borrow areas will not be dug continuously, and the size and shape of borrow pits will be decided by the Engineer.
- III. Borrow pits situated less than 0.8 km (if unavoidable) from villages and settlements should not be dug for more than 30 cm after removing 15cm of topsoil and should be drained.
- IV. The Contractor shall maintain erosion and drainage control in the vicinity of all borrow pits and make sure that surface drains do not affect the adjacent land or future reclamation. This needs to be rechecked by the engineer of the PIU.

- V. In case the borrow pit is on agricultural land, the depth of borrow pits shall not exceed 45 cm and may be dug out to a depth of not more than 30 cm after stripping the 15 cm top soil aside.
- VI. To prevent damages to adjacent properties, the Contractor shall ensure that an undisturbed buffer zone exists between the distributed borrow areas and adjacent land. Buffer zone shall be 3 m wide or equal to the depth of excavation whichever is greater.
- VII. In case of riverside or near any stream, borrow pit should be located not less than 15m from the toe of the bank, distance depending on the magnitude and duration of flood to be withstood.
- VIII. In no case shall be borrow pit be within 1.5m from the Toe line of the proposed embankment.

Borrow Areas located in Agricultural land, were un-avoidable

- I. The preservation of topsoil will be carried out in stockpile.
- II. A 15 cm topsoil will be stripped off from the borrow pit and this will be stored in stockpiles in a designated area for height not exceeding 2m and side slopes not steeper than 1:2 (Vertical: Horizontal).
- III. The depth of borrow pits will not be more than 30 cm after stripping the 15 cm topsoil aside.

Borrow Areas located in Elevated Lands

- I. The preservation of topsoil will be carried out in stockpile.
- II. A 15 cm topsoil will be stripped off from the borrow pit and this will be stored in stockpiles in a designated area for height not exceeding 2m and side slopes not steeper than 1:2 (Vertical: Horizontal).
- III. At location where private owners desire their fields to be leveled, the borrowing shall be done to a depth of not more than 1.5m or up to the level of surrounding fields

Borrow Areas near River side

- I. The preservation of topsoil will be carried out in stockpile.
- II. A 15 cm topsoil will be stripped off from the borrow pit and this will be stored in stockpiles in a designated area for height not exceeding 2m and side slopes not steeper than 1:2 (Vertical: Horizontal).
- III. Borrow area near to any surface water body will be at least at a distance of 15m from the toe of the bank or high flood level, whichever is maximum.

Borrow Areas near Settlements

- I. The preservation of topsoil will be carried out in stockpile.
- II. A 15 cm topsoil will be stripped off from the borrow pit and this will be stored in stockpiles in a designated area for height not exceeding 2m and side slopes not steeper than 1:2 (Vertical: Horizontal).
- III. Borrow pit location will be located at least 0.75 km from villages and settlements. If un-avoidable, the pit will not be dug for more than 30 cm and drains will be cut to facilitate drainage.
- IV. Borrow pits located in such location will be re-developed immediately after borrowing is completed. If spoils are dumped, that will be covered with a layer of stockpiled topsoil in accordance with compliance requirements with respect MOEF/HPCB guidelines.

Borrow Pits along the Road

- I. The preservation of topsoil will be carried out in stockpile.
- II. A 15 cm topsoil will be stripped off from the borrow pit and this will be stored in stockpiles in a designated area for height not exceeding 2m and side slopes not steeper than 1:2 (Vertical: Horizontal).
- III. Borrow pits along the road shall be discouraged.
- IV. It permitted by the Engineer; these shall not be dug continuously.
- V. Ridges of not less than 8m widths should be left at intervals not exceeding 300m.
- VI. Small drains shall be cut through the ridges of facilitate drainage.
- VII. The depth of the pits shall be so regulated that their bottom does not cut an imaginary line having a slope of 1 vertical to 4 horizontals projected from the edge of the final section of bank, the maximum depth of any case being limited to 1.5m.
- VIII. Also, no pit shall be dug within the offset width from the toe of the embankment required as per the consideration of stability with a minimum width of 10m.

Once used, all borrow areas would require rehabilitation as follows.

Re-development of Borrow Areas

The objective of the rehabilitation Programme is to return the borrow pit sites to a safe and secure area, which the general public should be able to safely enter and enjoy. Securing borrow pits in a stable condition is fundamental requirement of the rehabilitation process. This could be achieved by filling the borrow pit floor to approximately the access road level.

Re-development plan will be prepared by the Contractor before the start of work in line with the owners will require and to the satisfaction of owner.

The Borrow Areas will be rehabilitated as per following;

Depending on the choice of the individual landowner/community, the contractor shall prepare redevelopment plans for the borrow areas. The options can be: (i) Restoring the productive use of the land (ii) Development of detention ponds in barren areas;

Option I: Suitable in locations with high rainfall and productive areas;

- Topsoil must be placed, seeded, and mulched within 30 days of final grading if it is within a current growing season or within 30 days of the start of the next growing season.
- Vegetative material used in reclamation must consist of grasses, legumes, herbaceous, or woody plants or a combination thereof, useful to the community for the fuel and fodder needs.
- Plants must be planted during the first growing season following the reclamation phase.
- Selection and use of vegetative cover must take into account soil and site characteristics such as drainage, pH, nutrient availability, and climate to ensure permanent growth.
- The vegetative cover is acceptable if within one growing season of seeding, the planting of trees and shrubs results in a permanent stand, or regeneration and succession rate, sufficient to assure a 75% survival rate.

Option II: In barren land, the borrow areas can be redeveloped into detention ponds. These will be doubled up as water bodies and also for removal of sediment from runoff flowing through the ponds. Design of the detention basin depends upon the particle size, settling characteristics, residence time and land area. A minimum of 0.02 mm size particle with a settling velocity of 0.02 cm/sec (assuming specific gravity of solids 2.65) can be settled in the detention basin.

- Pond should be located at the lowest point in the catchment area. Care should be taken that the horizontal velocity should be less than settling velocity to prevent suspension or erosion of deposited materials.
- Minimum Effective Flow Path: 5 times the effective width
- Minimum Free Board: 0.15 m
- Minimum Free Settling Depth: 0.5 m
- Minimum Sediments Storage Depth: 0.5 m
- Maximum interior slope: 2H : 1V
- Maximum exterior slope: 3H : 1V
- The inlet structure should be such that incoming flow should distribute across the width of the pond.
- A pre-treatment sump with a screen should provide to remove coarse sediments.
- Settled sediment should be removed after each storm event or when the sediment capacity has exceeded 33% of design sediment storage volume.
- Accumulated sediment must be disposed of in a manner, which will prevent its re-entry into the site drainage system, or into any watercourse.

Note;

The Contractor will keep record of photographs of various stages i.e., before using materials from the location (pre-project), for the period borrowing activities (construction Phase) and after rehabilitation (post development), to ascertain the pre and post borrowing status of the area.

APPENDIX 2: QUARRY MATERIALS

The Contractor will finalize the locations in consultation with PMC and ESMU as per HP Mineral Policy 2013. The Contractor shall establish a new quarry only with the prior consent of the PMC only in cases when: (i) Lead from existing quarries is uneconomical and (ii) Alternative material sources are not available. The Contractor shall prepare a Redevelopment Plan for the quarry site and get it approved by the PMC.

The construction schedule and operations plan to be submitted to the PMC prior to commencement of work shall contain a detailed work plan for procuring materials that includes procurement, transportation and storage of quarry materials.

Operation & redevelopment plan (if a new quarry is opened):

- Photograph of the quarry site prior to commencement
- The quarry boundaries as well as location of the materials deposits, working equipment, stockpiling, access roads and final shape of the pit.
- Drainage and erosion control measures at site.
- Safety Measures during quarry operation.
- Design for redevelopment of exhaust site.

Option-A: Re vegetating the quarry to merge with surrounding landscape: This is done by conserving and reapplying the topsoil for the vegetative growth.

Option-B: Developing exhausted quarries as water bodies: The pit shall be reshaped and developed into pond, for harvesting rainwater. This option shall only be considered where the location of quarry is at the lowest point, i.e. surrounding areas/natural drainage slopes towards it.

CONSTRUCTION STAGE

Development of site: To minimize the adverse impact during excavation of material following measures need to be undertaken:

1. Adequate drainage system shall be provided to prevent the flooding of the excavated area
2. At the stockpiling locations, the Contractor shall construct sediment barriers to prevent the erosion of excavated material due to runoff
3. Construction of offices, laboratory, workshop and rest places shall be done in the up wind of the plant to minimize the adverse impact due to dust and noise.
4. The access road to the plant shall be constructed taking into consideration location of units and also slope of the ground to regulate the vehicle movement within the plant.
5. In case of storage of blasting material, all precautions shall be taken as per The Explosive Rules, 2008 (amendment 2019).

Quarry operations including safety

1. Overburden shall be removed and disposed in line with Guidelines of Debris Disposal Management.

2. During excavation, slopes shall be flatter than 20 degrees to prevent their sliding. In cases where quarry strata are good and where chances of sliding are less this restriction can be ignored.
3. In case of blasting, procedure and safety measures shall be taken as per The Explosive Rules, 2008 (amendment 2019)
4. The Contractor shall ensure that all workers related health and safety measures shall be done as per guidelines.
5. The Contractor shall ensure maintenance of crushers regularly as per manufacturer's recommendation.

Topsoil will be excavated and preserved during transportation of the material measures shall be taken to minimize the generation of dust and prevent accidents.

The ESMU and the PMC shall review the quarry site for the management measures during quarry operation, including the compliance to pollution norms.

POST CONSTRUCTION STAGE

The Contractor shall restore all haul roads constructed for transporting the material from the quarries to construction site to their original state.

The ESMU and the PMC shall be entrusted the responsibility of reviewing the quarry site for the progress of implementation of Redevelopment Plan. These shall include the following two cases;

- Redevelopment of quarries opened by the Contractor for the project
- Redevelopment of existing quarries operated by other agencies

In the first case, the Contractor shall be responsible for the Redevelopment Plan prior to completion after five years, during the defect liability period. The PMC and ESMU shall be responsible for reviewing this case of redevelopment prior to the issuing the defect liability certificate.

In the second case, the redevelopment of exhaust quarry shall be the responsibility of the agency providing the permit to ensure the implementation of Redevelopment Plan.

APPENDIX 3: GENERAL GUIDELINES FOR CONTRACTOR'S CONSTRUCTION WATER MANAGEMENT PLAN

During Construction, except bituminous works, water is required during all stages of road construction such as Embankment Sub-Grade; Granular sub-base (GSB) and Water Bound Macadam (WBM). Water will also be required for other purposes (drinking, cooking, washing etc). These water requirements will be met from available sources along road or by bore wells etc.

The estimated water requirements are 42 lakh liters during project period for civil works like embankment, sub-grades, bituminous work, concrete, dust suppression and daily consumptive use at work force camp, site offices, among others. The breakup of water requirement for different usage during the project cycle is given below is given below.

Estimated Construction Water Requirement for the project

S. No.	Activity	Unit	Quantity in litres required/meter length of road	Estimated total quantity of Water required (in lakhs)
1	Road/Embankment	Litres/metre	500	13
2	Subgrade/WBM	Litres/metre	250	6
3	Construction of CD Structures	Ls@10000 litres per location	-	1
4	Dust Suppression and camp site management	Litres/metre	250	6
5	On site sanitation & Drinking water	per day	5000	15
6	Camp Site Water Requirement	Litres	1000	3
7	Plantation of saplings/trees	Litres	5400000	12
Total Water Requirement				56
Add 5% for wastage and 20% for Contingency				70
Quantity of Water Requirement for entire Construction period				126
Quantity of Water Requirement KLD				42

Contractor will be required to calculate daily water requirements and identify the sources that can meet the requirements. Contractor for the purpose would require preparing a Water Management plan. The plan will consist of identified locations, timings to fetch water from these locations and all required permission from the authorities for approval to PMC.

During construction, the Contractor shall be responsible to monitor the following:

The arrangements worked out with the PRI/individual landowners for water extraction is adhered to;

- Extraction of water is restricted to construction requirement and domestic use of construction workers.

- Water requirement for curing of concrete shall be minimized by pooling of water over the concrete or by covering with wet gunny bags.
- Water used for mixing of mortar/concrete and subsequent curing is free from injurious amount of oil, acids, alkalis, salts, sugar, organic materials or other substances that may be deleterious to concrete or steel and this water should conform to Clause 1010 of MoRT&H “Specifications for Road and Bridge works – Fourth Revision” and IS: 456, and,
- The potable water used for drinking purposes of construction workers shall be as per the Indian Standard for Drinking Water IS: 10500, 1991.

Do’s and Don’ts for The Contractor

There are several dos and Don’ts for construction water usage for the Contractor as provided below;

- Contractor’s vehicles shall not be allowed to wash in the river or stream. This is to avoid potential pollution from pol residues.
- Contractors shall not use water from the community drinking water sources such as;
 - Public water supply schemes
 - Community spring water sources
 - Community hand pumps
 - Community bore wells /shallow tube wells
 - any water harvesting structures of community or Govt
 - Location of or the streams from which the community take drinking water
 - Contractor shall obtain all legal approvals and clearances from the concerned departments
 - Contractor shall consult the local communities where the water source has been identified
 - Various water sources available along the roadside are provided in appendix-15 (Layout maps of seasonal and permanent water sources) and to fetch water from these or such other sources a prior approval from competitive authority e.g. Irrigation and Public Health department, HP must be taken.

Post Construction Stage

Once the Contractor finishes its job, water source can be handed over to the local Panchayat or for local communities.

The two possible alternate uses of this structure would be;

- Local communities of this area can use the same to meet their water needs.
- This could be a water hole for the wildlife (if any) in that that area.

Prior to issuing project completion certificate to the contractor, the PMC shall verify that the premises of water extraction points are restored to their original status after construction.

APPENDIX 4: SELECTION AND MANAGEMENT OF CONSTRUCTION CAMP

Contractor would require plan for siting, development, management and restoration of construction camps to avoid or mitigate impacts on the environment. The area requirement for the construction camp shall depend upon the size of contract, number of labourers employed and the extent of machinery deployed. The key activities requiring addressal during the project stages are as follows.

Stages	Key Activities
Pre-construction	Siting
	Development
Construction	Maintenance
Post-Construction	Restoration

Pre-construction stage

- The Contractor shall identify the site for construction camp in consultation with the individual owners in case of private lands and the Gram Panchayat in case of Government lands. The suitable sites shall be selected and finalized in consultation with the PMC.
- The contractor will work out arrangements for setting up his facilities during the duration of construction with the land owner/Gram Panchayat. The arrangements will include the restoration of the site after the completion of construction. The arrangements will be verified by the PMC/PIU to enable redressal of grievances at a later stage of the project

Selection of construction camp/site locations	
<p>Avoid the following ...</p> <ul style="list-style-type: none"> • Lands close to habitations • Irrigated agricultural lands • Lands belonging to small farmers • Lands under village forests • Lands within 100m of community water bodies and water sources as rivers • Lands within 100m of watercourses • Low lying lands • Lands supporting dense vegetation • Grazing lands and lands with tenure rights • Lands where there is no willingness of the landowner to permit its use 	<p>Prefer the following ...</p> <ul style="list-style-type: none"> • Waste lands • Lands belonging to owners who look upon the temporary use as a source of income • Community lands or government land not used for beneficial purposes • Private non-irrigated lands where the owner is willing and • Lands with an existing access road

After finalization of the site, the contractor shall submit to the PMC a detailed layout plan for development of the construction camp, indicating the various structures to be constructed including the temporary structures to be put up, drainage and other facilities. The plan will include the redevelopment of sites to pre-construction stage.

Arrangements with landowners...
<p>The contractor shall submit to PMC the following:</p> <ul style="list-style-type: none"> • Written No-objection certificate of the owner/cultivator • Extent of land required and duration of the agreement • Photograph of the site in original condition • Details of site redevelopment after completion

Accommodation: The contractor shall provide, free of cost in the camp site, temporary living accommodation to all the workers employed by him for such a period as the construction/maintenance work is in progress.

Towards the provision and storage of drinking water at the construction camp, the contractor shall ensure the following provisions;

- The contractor shall provide for a sufficient supply of potable water in the construction camps, in earthen pots or any other suitable containers. The contractor shall identify suitable community water sources as hand pumps and ponds for procuring drinking water, in consultation with the Gram Panchayat.
- Only in the event of non-availability of other sources of potable water, the Contractor shall obtain water from an unprotected source, after the testing for its potability. Where water has to be drawn from an existing open well, the well shall be properly chlorinated before water is drawn from it for drinking. All such wells shall be entirely closed in and be provided with dust proof trap door.
- Every water supply or storage shall be at a distance of not less than 15m from any wastewater / sewage drain or other source of pollution. Water sources within 15m proximity of toilet, drain or any source of pollution will not be used as a source of drinking water in the project.
- A pump shall be fitted to each covered well, the trap door shall be kept locked and opened only for cleaning or inspection, which shall be done at least once a month.

In every site, adequate and suitable facilities for washing clothes and utensils shall be provided and maintained for the use of contract labor employed therein. Separate and adequate bathing facilities shall be provided for the use of male and female workers. Such facilities shall be conveniently accessible and shall be kept in clean and hygienic conditions.

Sanitary arrangements, latrines and urinals shall be provided in every work place on the following scale:

- Where female workers are employed, there shall be at least one latrine for every 25 females or part thereof.
- Where males are employed, there shall be at least one latrine for every 25 males or part thereof.
- Every latrine shall be under cover and so partitioned off as to secure privacy, and shall have a proper door and fastenings.
- Where workers of both sexes are employed, there shall be displayed outside each block of latrine and urinal, a notice in the language understood by the majority of the workers “For Men Only” or “For Women Only” as the case may be.
- The latrines and urinals shall be adequately lighted and shall be maintained in a clean sanitary condition at all times and
- Water shall be provided in or near the latrines and urinals by storage in suitable containers.

Arrangements for Waste Disposal;

- Disposal of sanitary wastes and excreta shall be into septic tanks.
- Kitchen wastes shall be disposed into soak pits. Wastewater from campsites will be discharged and disposed in a kitchen sump located preferably at least 15 meters from any body of water. Sump capacity should be at least 1.3 times the maximum volume of wastewater discharged per day. The bottom of the pit should be filled with coarse gravel and the sides shored up with board, etc. to prevent erosion and collapse of the pit.

- Solid wastes generated in the construction site shall be reused if recyclable or disposed of in land fill sites

First Aid Facilities;

- First Aid Box will be provided at every construction campsite and under the charge of a responsible person who shall always be readily available during working hours of the work place. He shall be adequately trained in administering first aid-treatment. Formal arrangement shall be prescribed to carry injured person or person suddenly taken ill to the nearest hospital.

Storage Site;

- Storage of Petrol/Oil/Lubricants: Brick on edge flooring or sand flooring will be provided at the storage places of Petrol/Oil/Lubricants to avoid soil and water contamination due to spillage.
- Storage of cement: Damp-proof flooring, as per IS codes
- Storage of blasting materials: Shall be as per the specific provisions of law.

Firefighting arrangement;

- Demarcation of area susceptible to fires with cautionary signage,
- Portable fire extinguishers and/or sand baskets shall be provided at easily accessible locations in the event of fire,
- Contractor shall educate the workers on usage of these equipment

Interactions with host communities;

- To ensure that there is no conflict of the migrant labor with the host communities, the contractor shall issue identity cards to labourers and residents of construction camps.

Construction Stage:

Construction camps shall be maintained free from litter and in hygienic condition. It should be kept free from spillage of oil, grease or bitumen. Any spillage should be cleaned immediately to avoid pollution of soil, water stored or adjacent water bodies. Following precautions need to be taken in construction camps.

- Measures to ensure that no leaching of oil and grease into water bodies or underground water takes place
- Wastewater should not be disposed into water bodies
- Regular collection of solid wastes should be undertaken and should be disposed of safely
- All consumables as the first aid equipment, cleaning equipment for maintaining hygiene and sanitation should be recouped immediately

PMC will monitor the cleanliness of construction campsites and ensure that the sites are properly maintained throughout the period of the contract.

Post Construction Stage:

At the completion of construction, all construction camp facilities shall be dismantled and removed from the site. The site shall be restored to a condition in no way inferior to the condition prior to commencement of the works. Various activities to be carried out for site restoration are:

- Oil and fuel contaminated soil shall be removed and transported and buried in waste disposal areas.
- On the construction camp site, saplings of species similar to that of cut trees shall be planted.
- Saplings planted shall be handed over to the community or the land owner for further maintenance and watering
- Soak pits and septic tanks shall be covered and effectively sealed off

APPENDIX 5: DEBRIS DISPOSAL SITE MANAGEMENT

The excess debris will be required to dispose of at pre identified debris disposal locations by Contractor. If not disposed of carefully, the erosion could take these loose materials in to nullahs and then further to the major River basin. Hence the Contractor needs to plan for the disposal of debris in such a way, so that it may not harm or create any hindrance for the implementation of the project.

A poor management may lead to very poor engineering practices, community conflicts and the stoppage of the works etc. and that would incur huge losses to all concerned. The possible impacts due to poor management are described below;

- **Obstruction to natural watercourse**

The materials if not disposed of properly would be taken by the running water to the lowest portion of the valleys creating huge obstruction to free flow of natural stream water. If people are residing nearby that would affect their life by way of flooding or by spoiling the premises.

- **Siltation in surface water reservoirs**

Most of the materials would be ultimately taken down stream through rivers and ultimately depositing into reservoirs leading to heavy siltation. This in turn would reduce the reservoir capacity substantially within a very short span. This could incur huge losses to the exchequer. De-siltation is also expensive and normally carried out after many years of operation of reservoirs in the natural circumstances.

- **Soil erosion**

Massive soil erosion is the most direct impact of the debris excavation. The precipitation and the consequent run off would erode the loose materials by way of suspension and solution. Once reached up to the mainstream courses, even the big boulders would be transported down due to the steep gradients available along the stream courses.

- **Flash floods**

Debris spilled over valley or nallah sometimes can be fatal, if there are houses or roads downstream. Houses and roads (having vehicles) can be flooded away.

- **Spoiling of agricultural land**

As a usual practice mainly due to poor planning and limited resources, the Contractor usually throws the materials to the nearby valley areas. This would be taken down to the private agricultural areas. The farmer will incur huge losses and may even sue the Contractor. As a result, the project could be stopped indefinitely leading to losses for the people of the State.

During the execution phase, Contractor should plan for its safe disposal according to the geographical status of area. For this Contractor will be required to prepare a “Debris disposal management plan”.

- The contractor shall identify the activities during construction, that have the potential to generate waste and work out measures for the same in the construction schedule to be submitted to the PMC. For the disposal of excess cut and unsuitable (non-toxic) materials, the contractor shall identify the location for disposal in consultation with the community / Gram Panchayat. Any toxic materials shall be disposed in existing landfill sites that comply with legislative requirements. Prior to disposal of wastes onto private/community land, it shall be the responsibility of the Contractor to obtain a No-objection Certificate (NOC) from the land owner/community.
- The Contractor shall educate his workforce on issues related to disposal of waste, the location of disposal site as well as the specific requirement for the management of these sites

The locations of Disposal sites have to be selected such that:

- No residential areas are located downwind side of these locations,
- Disposal sites shall be located at least 1000 m away from sensitive locations like Settlements, Water body notified forest areas, Sanctuaries or any other sensitive Locations.
- Disposal sites do not contaminate any water sources, rivers etc. for this site should be located away from water body, and Disposal site should be lined properly to prevent infiltration of water.
- Public perception about the location of debris disposal site has to be obtained before finalizing the location.
- The Plan must be approved by Environment Specialist of Supervision Consultant.

Contractor needs to plan the disposal in the following way

- Identify the disposal area.
- Estimate the disposal quantities.
- Consult with all stake holders and prepare an agreement with landowner.
- Prepare a suitable design for the safe disposal
- Design should have provision of protection (gabion etc.) at the base, grass or shrubs plantation on the naked slope.
- Need to photograph the present land use and condition of the area.
- Submit the copy of agreement, design, photographs, and estimate along with revenue records (Jamabandi, Tatima and Musabbi etc) to the supervision consultant.
- After getting the plan approved, dispose of the debris in the identified location only.
- Construct all required protection structures prior to disposal (e.g. retaining wall).
- Compact of the materials after disposal.

Rehabilitation procedures

After completion, the debris disposal sites filled only up to the ground level could be rehabilitated as per guidelines below and to be decided by the supervision consultant.

- The debris disposal sites have to be suitably rehabilitated by planting local species of shrubs and other plants. Local species of trees has also to be planted so that the landscape is coherent and is in harmony with its various components (bioengineering methods).
- In cases where a debris disposal sites is near to the local village community settlements; it could be converted into a play field by spreading the disposed debris evenly on the ground. Such playground could be made coherent with the landscape by planting trees all along the periphery of the playground.
- Some of the debris disposal sites could be used either for plantation or for growing agricultural produce such as ginger, turmeric or oranges etc.
- Care should always be taken to maintain the hydrological flow in the area.

In case of disposal of wastes on private land, certificate of Completion of Reclamation is to be obtained by the Contractor from the landowner that “the land is restored to his satisfaction”.

The following are the identified debris disposal locations:-

S. No.	Location	Type of Land	Capacity (m³), Area (Ha)
1	2+750 (LHS)	Private Land	15,000m³ (L=30m W=100m; H=5m)

Contractor will also approach district administration for the identification of suitable debris disposable sites/land for debris, as per Construction and demolition waste management rules, 2016.

APPENDIX 6: TRAFFIC AND SAFETY MANAGEMENT DURING CONSTRUCTION

The safety and health concerns of the workers and the public are impacted due to the hazards created during the construction of road. Contractor is required to prepare a plan for the effective implementation of the traffic safety and safety arrangements along the construction zones. Traffic control refers to the use of temporary traffic control devices to protect workers and to move road users safely through a work zone. A traffic management plan is usually required to outline the traffic hazards, and to specify the measures needed for traffic control. Health and safety legislation focus on safety requirements including increased visibility of the workers, signage, and signaling.

Concerns on Safety:

General Public due to.....	Workers due to.....
<ul style="list-style-type: none"> • Improper scheduling of construction activities especially near the settlements • Parking of equipment and vehicles at the end of the day is likely to cause accidents to the public especially during night hours. • Transportation of uncovered loose material or spillage of material increases the chances of accidents to road users and surrounding settlements. 	<ul style="list-style-type: none"> • Improper handling of materials like bitumen, oil and other flammable material at construction sites, likely to cause safety concerns to the workers. • Lack of safety measures such as alarm, awareness and safety equipment result in accidents, especially working with or around heavy machinery / equipment.

Management during Construction

Contractor shall not open numerous construction fronts simultaneously. The number of opening fronts should depend on the capability and capacity of the Contractor to effectively manage the work sites with his dedicated staff. Prior to opening of new work fronts, after the completion of the work, the area should be safely closed in all respects with suitable information or sign boards.

Contractor will provide:

- Protective footwear, protective goggles and nose masks to the workers employed in asphalt works, concrete works, crusher etc.
- Welder's protective eye-shields to workers who are engaged in welding works
- Earplugs to workers exposed to loud noise, and workers working in crushing or compaction
- The Contractor will comply with all regulations regarding safe scaffolding, ladders, working platforms, gangway, stairwells, excavations, trenches and safe means of entry and egress.
- The Contractor will comply with all the precautions as required for ensuring the safety of the workmen as per the International Labour Organization (ILO).
- The Contractor will make sure that during the construction work all relevant provisions of Building and other Construction Workers (regulation of Employment and Conditions of Services) Act, 1996 are adhered to.
- The Contractor will not employ any person below the age of 14 years for any work and no woman will be employed on the work of painting with products containing lead in any form.
- The Contractor will also ensure that no paint containing lead or lead products is used except in the form of paste or readymade paint.

- Contractor will provide facemasks for use to the workers when paint is applied in the form of spray or a surface having lead paint dry is rubbed and PMC rapped.
- The Contractor will mark ‘hard hat’ and ‘no smoking’ and other ‘high risk’ areas and enforce non-compliance of use of PPE with zero tolerance. These will be reflected in the Construction Safety Plan to be prepared by the Contractor during mobilization and will be approved by PMC and ESMU.
- To promote and encourage a Safety culture, senior most engineers in Contractors team and in the PMC’s teams shall wear helmets and safety jackets.

List of Personal Protective Equipment

S. No	Part of the Body	Personal Protective Equipment	S. No	Part of the Body	Personal Protective Equipment
1	Eye	Safety Glasses, Goggles	5	Feet	Safety Shoes
2	Face	Face Shields	6	Hands and arms	Gloves
3	Nose	Nose Masks	7	Bodies	Vests
4	Head	Helmets	8	Hearing	Earplugs, Earmuffs

The Contractor will take all necessary measures for the safety of traffic during construction and provide, erect and maintain barricades, including signs, markings, flags, lights and flagmen as proposed in the Traffic Control Plan/Drawings and as required by the Environmental Expert of PMC for the information and protection of traffic approaching or passing through the sections of any existing cross roads.

The Contractor will ensure that all signs, barricades, pavement markings are provided as per the MoRTH specifications. Before taking up of construction on any section of the existing lanes of the highway, a Traffic Management Plan will be devised and implemented to the satisfaction of the Environmental Specialist of PMC.

List of Traffic Safety Equipment

S. No	Signs	S. No	Signs
1	Barricading	6	Flagmen
2	Men at Work	7	Narrow Signs
3	Keep Left	8	Lantern (Amber Blinker)
5	Go Slow	9	Traffic Control Lights

Additional provisions need to be undertaken for safety at site;

- Adequate lighting arrangements.
- Adequate drainage system to avoid any stagnation of water.
- Lined surface with slope 1:40 (V:H) and provision of lined pit at the bottom, at the storage and handling area of bitumen and oil, as well as at the location of generator (grease trap).
- Facilities for administering first aid.

First Aid Kit, distinctly marked with Red Cross on white background and shall contain minimum of following:

- 6 small-sterilized dressings
- 3 medium and large sterilized dressings
- 1 bottle (30 ml.) containing 2 % alcoholic solution of iodine
- 1 bottle (30 ml) containing Sal volatile

- 1 snakebite lancet
- 1 pair sterilized scissors
- 100 tablets of aspirin
- Ointment for burns
- A suitable surgical antiseptic solution

Adequate arrangement shall be made for immediate recoupment of the equipment, whenever necessary.

Trained personnel in charge of first aid treatment to be readily available during working hours at construction site.

Suitable transport to the nearest approachable hospital should be made available.

The following measures need to be adopted by the Contractor to address public safety concerns:

The Contractor shall schedule the construction activities taking into consideration factors such as:

- Frequent movement of the people during sowing and harvesting of crops, local festivals etc.
- Settlement areas;
- Locations having sensitive receptors; Traffic and safety management on these locations needs additional planning because of the frequent movement of students and patients.

Note:

- Safety Jackets and helmets should be provided to all the workers/engineers working on the road.
- Fixed mobile solid barricades must be placed between the workmen and traffic or pedestrian and traffic.
- All the Safety Signs should be according to IRC: 67 and IRC: SP: 55: 2001.

A typical diagram showing traffic management during construction phase is given below for reference.

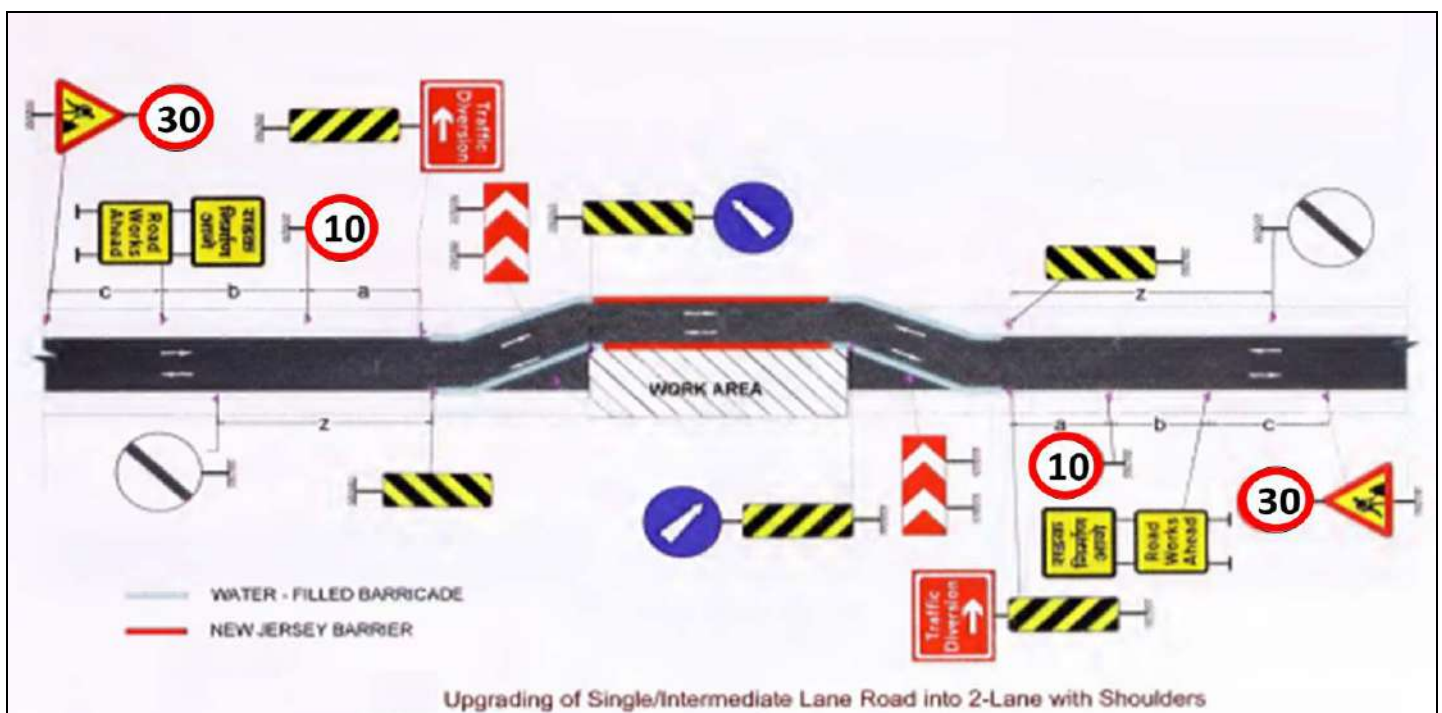

APPENDIX 7: FORMATS FOR ENVIRONMENTAL REPORTING

RF 1: CONSTRUCTION CAMP/ PLANT SITE MANAGEMENT PLAN

S. NO	Description	Compliance
1	Name of the location	
2	Nearest road chainage.	
3	Name of the owner	
4	Area involved	
5	Arrangements with the owner (agreement with landowner, including the restoration aspects, should be attached as an Annexure)	
6	Existing land use	
7	Photographs depicting the present condition of the construction camp and access road.	
8	Land use of the area surrounding the borrow area including a map	
9	Site layout plan of the construction camp	
10	Establishment and maintenance of demarcated and labelled different areas within the camp	
11	Number of trees to be removed, if any, along with compensation measures	
12	Proposed topsoil management	
13	Activities planned in the construction camp	
14	Machinery & equipment to be used on site	
15	Labour camp facilities onsite	
16	Health facilities	
17	Site drainage provisions	
18	Copy of the consents to establish and operate should be attached as an Annexure	
19	Conditions laid down in the clearance / licenses and plans	
20	Staff strength and details such as contractor staff vs sub contractors, women labour, migrant vs local labour and skilled & unskilled labour	
21	Access road condition and proposed maintenance	
22	Safety provision such as fire protection equipment and personal protective measure.	
23	Closure / completion plan	Format RF: 1A

RF 1A: CLOSURE PLAN CONSTRUCTION CAMP AND/ PLANT SITE

S. No	Description	Compliance
1	Name / identity of location	
2	Distance from the Project Road and side	
3	Name of the owner	
4	Details of the Land i). Survey Number ii). Boundaries iii). Other Revenue Details	
5	Details of settlements, sensitive areas, water bodies, wells and bore wells within 500 m Population in Numbers Name of the Village Distance from the construction camp Details of water bodies/ sensitive areas/ wells/ bore wells	
6	Physical Details Number of Labour Stationed Number of Dwellings Constructed Number of toilets provided Were dwellings demolished Were the wastewater treatment facilities demolished and cleared? Was the solid waste generated cleared and disposed of properly, if yes specify the location and quantity? Whether any soil was contaminated with oils and waste oils was cleared and disposed safely, if yes specify the location and quantity. Was scrap generated while the construction removed, if yes specify the details such as where, when, to whom and quantity.	
7	Land Use before Establishment Proposed Use after completion of works	

F 2: BORROW AREA NO

S. No	Description	Compliance
1	Name / identity of location	
2	Nearest project road chainage	
3	Name of the owner	
4	Area involved/capacity/quantity	
5	Type of material proposed to be taken	
6	Arrangement with the owner including restoration aspect.	
7	Existing land use	
8	Land use of the area surrounding the proposed area	
9	A map of the area	
10	Number of trees to be removed, if any along with the compensation measure	
11	Topsoil management if required	
12	Access road condition and proposed maintenance	
13	Photograph depicting the present condition of the proposed area and access road	
14	Closure / completion plan	Format RF 2A

RF 2A: CLOSURE PLAN FOR BORROW AREA

S. No	Description	Compliance
1	Name / identity of location	
2	Nearest Project chainage, distance from the Project Road and side	
3	Name of the owner	
4	Details of the Land i. Survey Number ii. Boundaries iii. Other Revenue Details	
5	Details of settlements, sensitive areas, water bodies within 500 m Population in Number Name of the Village Distance from the borrow area. Details of water bodies/ sensitive areas/ wells/ bore wells	
6	Physical Details Length and width in meters Depth excavated in meters Quantity Excavated in cum Type of materials excavated	
7	Land Use before Opening Proposed Use before opening Details of surroundings	
8	Drawing showing the dimensions of the borrow areas, access roads and features of surrounding	
9	Number of trees removed(girth>300mm), if any along with the compensation measure	
10	Details of topsoil Quantity excavated in cum Where was it used	
11	Initial access road condition and final access road condition	
12	Photographs depicting the original condition, during the operation, topsoil management, and after closure	
13	Copy of the agreement with the Owner Details of the agreed redevelopment if any	
14	Land use after rehabilitation Details should be submitted if the final land use changed from the original land use	
15	Satisfaction certificate from the owner	
16	Details of the practical problems faced, and solutions adopted, if any during the operation phase	

RF3: CONSTRUCTION CAMP / PLANT AND ENVIRONMENTAL MANAGEMENT

S. No	Issue	Status
		Camp-1
1	Drainage System 1. Closed drainage	
2	Disposal for Wastewater 1. Kitchen wastewater 2. Wastewater from water closets 3. Wastewater from bathrooms 4. Wastewater from the vehicular washings.	
3	Collection and Disposal of Solid Waste 1. Waste from the office 2. Waste from the kitchen 3. Waste from sweeping	
4	Drinking Water facility Source with quantity	

S. No	Issue	Status
		Camp-1
	No of bore wells with capacity Location of the well and bore well Any treatment facility No of overheads tanks Test results of the Drinking water Any license obtained	
5	First Aid Facility	
6	Roads in Camp Site Type of road Dust suppression practicing or not, if the roads are not tarred. Condition of the road.	
7	Fuel Storage 1. Impervious Base 2. Spills and Wastewater will be collected in a sump 3. Number of drums where wastes are collected. 4. Number of drums disposed	
8	Garbage & Night Soil 1. Provision of Garbage Bins 2. Separation of Polythene materials 3. Records of solid waste removal from septic tanks	

RF 4: TOPSOIL MANAGEMENT

S. No.	Chainage in km	Quantity in cum	Whether Preserved in accordance with specifications	Remarks
1				
2				
3				
4				
5				
6				
7				
8				

RF 5: CONSTRUCTION PLANTS AND POLLUTION CONTROL

S. No.	Construction Plant	Locations	Capacity	Description of Pollution Control System/ Equipment	Remarks
1					
2					
3					
4					
5					
6					
7					

RF 6: MACHINERY/ VEHICLES AND POLLUTION CONTROL

S. No	Machinery / vehicles with capacity	Diesel consumed during the month	Engine oil consumed during the month	PUC certificate no./validity	Machinery new/ old	Remarks
1						
2						
3						
4						

RF 7: DETAILS OF THE DG SETS WITH THE POLLUTION CONTROL EQUIPMENT

S. No	Capacity in KVA	Vertical Stack If provided height in m	Noise Control System	Remarks
Camp-1				

S. No	Capacity in KVA	Vertical Stack If provided height in m	Noise Control System	Remarks
Camp -II				
Crusher -I				
Plant Site -I				
Construction Works				

RF 8: DETAILS OF OIL STORAGE

S. No	Type of Product	Location	Number of Barrels	Capacity of barrels in Litres	Increase/ Decrease in Storage	Stored on Impervious base (Yes/No)	Remarks
1	Diesel						
2	Petrol						
3	Engine Oils						
4	Lubricants						

RF 9: WORKING AT WATER COURSE AND POLLUTION CONTROL MEASURES

S. No	Location	Type	Stream/ Canal Diversion	Silt Fencing	Remarks

RF 10: DETAILS OF THE GROUND WATER EXTRACTION

S. No	Location	Capacity of Motor Installed in HP	Quantity of water drawn in Kilo litres			Ground water department Permission	Type of source
			During the month	Up to end of last month	Total		

RF 11: PERSONAL PROTECTIVE EQUIPMENT

S. No	Details of Equipment	Total Procured in No	Distributed in No	Available in Store in No	Remarks
1	Helmets				

S. No	Details of Equipment	Total Procured in No	Distributed in No	Available in Store in No	Remarks
2	Safety Shoes				
3	Safety Shoes				
4	Nose Masks				
5	Hand Gloves				
6	Goggles				
7	Safety Belts				
8	Ear Plugs				
9	Reflective Jackets				
10	Gum Boots				

RF 12: STATUS OF CONSENTS FOR WATER EXTRACTION

Plant	Consent	Number / Status	Validity Date	Remarks

RF 13: DEVIATIONS WITH CORRECTIVE ACTIONS

S.No	Deviation	Corrective Actions	Schedule

RF 14: IMPLEMENTATION OF ENHANCEMENT MEASURES FOR CULTURAL PROPERTIES, WATER HARVESTING STRUCTURES

S. No	Type of Enhancement	Side of the Road (R/L)	Progress of Completion		Reasons of delay if any
			Target date	Actual Completion date	

RF 15: IDENTIFICATION OF DISPOSAL SITE LOCATIONS

(To be filled by the Contractor)

Name of Corridor _____

Link No. _____

(Give chainages and nearest settlements from both ends)

S. No	Criteria on which information for each site is to be collected	Site 1	Site 2	Site 3	Site 4
1	Existing Land Use				
2	Area covered (m2)				
3	Total Material that can be dumped within the site (m3)				
4	Depth to which dumping is feasible (m)				
5	Distance of nearest watercourse (m)				
6	Nearest Settlement (m)				
7	Date/s of Community Consultation/s				
8	Whether the community is agreeable to siting of dumping site (Y/N)				
9	Date of Permission from Villager/local community				
10	Proposed future use of the Site				
11	Selected Site (tick any one column only)				

Enclosures (Tick as appropriate)

Map of each location

Photographs

Each Disposal location

Each community consultation

Photocopy of Agreement (along with revenue record of the owner)

Remark

Submitted
Signature

Name

Designation

Contractor

Checked
Signature

Name

Environmental Engineer.
Construction Supervision Consultant

Approved
Signature

Name

Executive Engineer PWD

RF 16: FORMATS FOR GRIEVANCE REDRESSAL MECHANISM DURING CONSTRUCTION

A	PROJECT DETAILS		INFORMATION		
1	Name of the Project				
2	Name and address of the Contractor				
3	Contract Date and Duration				
B	Details of Complaints Received		Site Name		
Sl. No	Date of Complaint	Name and Address of Person with Contact Details	Complaint	Action Taken with Date	Signature of Environmental representative of Contractor
1					
2					

A Register in this format shall be maintained at each site office of the contractor. This same format shall be used to compile and report the details of received at all sites to complaints received at all sites to the PMC along with the monthly Report of the contractor. The Environmental Engineer of PMC has to give instructions to the contractor, if any further action has to be taken on any complaint

RF 17: REPORTING FORMAT FOR WORK FORCE MANAGEMENT

A	PROJECT DETAILS		DATE OF REPORTING		
1	Name of the package and Corridor				
2	Name and Address of the contractor				
3	Contract date and duration				
4	Name of Work Site with Sl. No. in register of site				
B	Status of work force				
S. No	Category of work force	Work force in the Previous Month (No)	Work Force added in the reporting month (No.)	Work Force left in the reporting month (No.)	Total Work Force in the reporting month (No.)
1	Unskilled Labourers				
2	Skilled labourers				
3	Supervisors				
4	Engineers				
5	Office Staff				
6	Sub Total				
7	Grand Total				

C. Categorization of Work Force

S. No	Category of work Force	Male		Female		Employment Status		Residential Status		Accommodation Status	
		< 18 years	< 18 years	< 18 years	< 18 years	Regular	Temporary	Migrant	Local	Staying in Labour Camp/Quarters	Others
1	Unskilled Labourers										
2	Skilled labourers										
3	Supervisors										
4	Engineers										
5	Office Staff										
	Sub Total										
	Grand Total										
D. Details of the non-working migrated people, living in the labour camps/Staff Quarters as part of work force family											
No. of Children (0-6 yrs)			No. of Children (7-18 yrs)			No of Adults			Grand Total		
E. Submission Details											
		Submitted by (Environmental Officer of the Contractor)						Approved By (Environmental Engineer of PMC)			
Signature & Date											
Name											
Designation											
Remarks by PMC											

Note:

Contractor must fill and submit this format to the PMC along with the Monthly Report. In addition to that, the contractor must maintain the database of work force in the form of a register. An attendance register for the work force should also be maintained by the Contractor. Contractor must report the details of migrant work force to the nearest Police station. The PMC must visit the site and verify the details. The Environmental Engineer of PMC must give back a copy of this format to the contractor after his approval with remarks.

RF-18: REPORTING FORMAT FOR OCCUPATIONAL HEALTH AND SAFETY MEASURES

A	Project Details	Date of reporting:	
1	Name of the package and Corridor:		
2	Name and Address of the contractor:		
3	Contract date and duration:		
4	Status of completion of the project:		
B	Implementation Status of Health and Safety Measures		
S. No	Health and Safety Measures	Implementation Status(Yes/No)	Remarks
1	Appointment of qualified Environment and Safety Engineer		
2	Approval for Construction Safety Management Plan by the Engineer		
3	Provision for flags and warning lights for potential hazards		
4	Provision of adequate staging, from work and access (ladders and handrail) for works at a height of more than 3.0m		
5	Provision of adequate Shorting/ bracing/barricading/lighting for all deep excavations of more than 3.0m depth		
6	Provision for enough lighting epically for night-time work		
7	Construction Workers Safety-Provision of personnel protective equipment		
	A. Helmets		
	B. Safety Shoes		
	C. Dust Masks		
	D. Hand Gloves		
	E. Safety Belts		
	F. Reflective Jackets		
	G. Ear Plugs for Labour		
8	Workers engaged in welding works shall be provided with welder protective shields		
9	All vehicles are provided with reverse horns		

10	All Scaffolds, ladders and other safety devices shall be maintained in as safe and sound condition		
11	Ensuring the sanitary conditions and all waste disposal procedures & methods in the camp		
12	Ensuring the sanitary conditions and all waste disposal procedures & methods in the camps.		
13	Provisions for insurance coverage to the workers		
C	Submission Details		
	Submitted by (Environmental representative of the Contractor)	Approved By (Environmental Specialist of PMC)	
Signature & Date			
Name			
Designation			
Remarks by PMC:			

Note:

Contractor must fill and submit these formats to the PMC along with the Monthly Report. The PMC must visit the site and verify the details. Further mitigation measures, if required, can be suggested by the PMC. The Environmental Engineer of PMC must give back a copy of this format to the contractor after his approval with remarks.

RF 19: FOR ROAD SAFETY MEASURES DURING CONSTRUCTION

A	Project Details	Date of Reporting:	
	Name of Package and Corridor		
	Name and address of the		
	Contract date and duration		
	Status of completion of the project		
B	Details of Safety Measures		
S. No	Safety Measures	Compliance Status (Yes/no)	Remarks
a	General		
1	A qualified Environment and Safety Engineer should be appointed		
2	A Traffic Management Plan should be prepared in accordance with IRC: SP: 55- 2001 and got approved by the Engineer		
3	Maintenance of existing road stretches handed over to the Contractor should be carried out		
b	Details of Construction Zone		
1	Length of transition sub zone should be min 50 m for a speed of 50km/hr		
2	Length of work sub zone in urban stretch should be <2 km		
3	Length of work sub zone in rural stretch should be 5-10 km		
c	Signage's in construction zones		
1	Sign saying "Men at Work" should be kept 1 km ahead of Transition sub zone		
2	Supplementary sign saying Diversion 1km should be provided		
3	Sign saying „Road Closed ahead" should be provided		
4	Compulsory Tom Right/Left sign should be provided		
5	Detour sign should be placed		
6	Sharp Deviation sign should be placed at end of advance warning sub zone		
7	Signage should be provided in Transition Sub Work Zone		
8	Signage saying, Keep Right/Left should be provided		
9	Signage should be placed in work sub zone		
10	Hazard Marker should be placed where railing for CD structure on diversion starts		
11	Barricade should be provided on either side of work sub zone		

12	Flags and warning lights should be provided at Construction zones		
13	Flag persons should be provided for traffic control		
14	Metal drum /empty bitumen drum delineator, painted in circumferential strips of alternate black and white 100mm wide 2 coats fitted with reflectors 3 Nos of 7.5cm diameter or Barricades/caution tapes should be provided in construction zones		
15	Plastic crash barriers should be provided		
16	Demarcations (fencing, guarding and watching) should be provided at bridge / culvert construction sites		
17	Arrangements should be made for controlled access and entry to Construction zones		
18	Regular Inspection of Work Zone Traffic Control Devices should be carried out by authorized contractor personnel		
19	All vehicles should be provided with reverse horns		
20	Speed of construction vehicles should be controlled through road safety training of drivers		
d	Signage in Termination sub zone		
1	Sign for indication of end of work zone should be placed 120m from end of termination sub zone		
e	Road Delineators		
1	Roadway indicators should be provided		
2	Hazard markers should be provided		
3	Object markers should be provided		
f	Submission Details		
	Submitted by (Environment & Safety Engineer of Contractor)	Approved by (Environmental Specialist of PMC)	
	Signature & date		
	Name		
	Designation		

Note: Contractor must fill this format and submit to the PMC along with the Monthly Report. The PMC must visit the sites and verify the details. Additional safety measures, if required, can be suggested by the PMC. The Environmental Engineer of PMC must give back a copy of this format to the contractor after his approval with remarks.

RF 20: FORMAT FOR REGISTERING OF ACCIDENTS AND ITS REPORTING

A	Project Details	Date of Reporting	
1	Name of package and Corridor		
2	Name and address of the contractor		
3	Contract date and duration		
4	Status of completion of the Project		
B	Details of Accident and People Involved in Accident		
	Name of site where accident happened		
	Name and address of people involved in the accident		
	Whether Contractor's personal or General public		
	Details of Injury		
	Details of compensation given		
C	Type of Accident (√)		
	Fall of person from a height		Explosion
	Slip,trip or fall on same level		Fire
	Struck against fixed objects		Contact with hot or corrosive substance
	Struck by flying or falling objects		Contact with poisonous gas or toxic substances.
	Struck by moving objects		Contact with poisonous gas or toxic substances.
	Struck/caught by cable		Hand tool accident
	Stepping on hall etc.		Vehicle/Mobile plant accident
	Handling without machinery		Machinery operation accident
	Crushing/burying		Other (please specify)
	Drowning or asphyxiation		
D	Agent Involved in Accident (√)		
	Machinery		Stair edge
	portable power appliance		Excavation/underground working
	Vehicle or associated equipment / machinery		Ladder
	Material being handled, used or stored		Scaffolding/gondola
	Gas, vapour, dust, fume or oxygen		Construction formwork, shuttering and false work
	Hand tools		Electricity supply cable, wiring switchboard and associated equipment
	Floor edge		Nail, splinter or chipping
	Floor opening		Other (please specify)
	Left shaft		
E	Unsafe Action Relevant to the Accident (√)		
	Operating without authority		Failure to use proper footwear
	Failure to secure objects		Failure to use eye protector
	Making safety devices inoperative		Failure to use respirator
	Working on moving or dangerous equipment		Failure to use proper clothing

	Using un-safety equipment			Failure to use warn others or given proper signals
	Adopting unsafe position or posture			Horseplay
	Operating or working at unsafe speed			No unsafe action
	Unsafe loading, Placing, mixing et			Other (please specify)
	Failure to use helmet			
F	Lack of Safety Measures Relevant to the Accident (√)			
	No protective gear			Unsafe layout of job, traffic etc.
	Defective protective gear			Unsafe process of Job methods
	Improper dress/footwear			Poor housekeeping
	Improper guarding			Lack of warning system
	Improve ventilation			Defective tool, machinery or material
	Improper illumination			No unsafe condition
	Improper procedure			Other (please specify)
G	Personal Factor Relevant to the Accident (√)			
	Incorrect attitude/motive			No unsafe personal factor
	Unsafe act by another person			Other (please specify)
H	Details of Corrective and Prevention action taken			
1				
2				
3				
I	Submission details			
	Submitted by (Environment & Safety Engineer of Contractor)		Approved by (Environment Specialist of PMC)	
	Signature & Date			
	Name			
	Designation			
	Remarks by PMC			

RF 21: REPORTING FORMAT FOR MONTHLY REPORT FROM CONTRACTOR TO PMC

A Project Details		Information							
1	Name of Package and Corridor								
2	Name and address of the Contractor								
3	Contract date and duration								
B Physical Progress Report									
S. No	Enhancement Measures	Physical Target (Nos)	Units carried over from previous month	Units started in reporting months	Units completed in reporting months	Unit carried over to next month	Cumulative units completed till end of reporting month	% target completed	Remarks/Reasons for delay
		(a)	(b)	(c)	(d=a+b+c)				
1	Noise Barrier								
2	Hand Pumps								
3	Bus Shelter								
4	Sign Board								
5	Preserving and landscaping cultural properties								
6	Constructing new Well								
7	Providing new water taps								
8	Planting trees along roadside								
9	Planting trees on inner side of sound insulating wall								
C Details of Sites for Project Ancillary Facility									
1	Construction Camp								
2	Labour Camp								
3	Quarry & Stone Crusher Unit								
4	Borrow Area								
5	Debris disposal sites								
6	Water								

<i>A site will be considered closed after redeveloping and obtaining closure certificate from PMC</i>						
D	Summary of Machinery and equipment available					
S. No	Type of equipment/machinery/vehicles	Nos. Available	Validity date of PUC certificate (as applicable)	Remarks		
1						
2						
E						
S.No.	Details of Notices issued by PMC	Date of Issue	Type of Lapse (Major/Minor)	Notice no	Corrective action taken	Remarks
<i>* In case of minor lapse, specify whether original notice, first reminder or second reminder.</i>						
F	Reporting Format	Yes/No	S. No	Reporting Format	Yes/No	
1	Format for Register of sites opened and closed and its reporting		8	Reporting Format for Register of Accident and its reporting		
2	Format for Register of complaints and its reporting		9	Reporting Format for Enhancement Measures of Cultural Properties		
3	Reporting Format for Work Force Management		10	Reporting Format for Noise Barrier Construction		
4	Reporting Format for Occupational Health and Safety Measures		11	Reporting Format for Enhancement Measures Other than Cultural Properties		
5	Reporting Format for Topsoil Conservation		12	Reporting Format for Tree Plantation		
6	Reporting Format for Water Sprinkling for Dust Suppression		13	Reporting Format for Environmental Quality Monitoring		
7	Reporting Format for Road Safety Measures During Construction					
G	Submission Details					
		Submitted by (Environment & Safety Engineer of Contractor)		Approved by (Environment Specialist of PMC)		
Signature & Date						
Name						
Designation						
Remarks by PMC						

APPENDIX 8: NATIONAL STANDARDS OF AIR, NOISE, WATER AND SOIL

National Ambient Air Quality Standards

Pollutant	Time Weighted Average	Concentration in Ambient Air		Methods of Measurement
		Industrial, Residential, Rural and other Areas	Ecologically Sensitive Area	
Sulphur Dioxide (SO ₂), µg/m ³	Annual * 24 Hours **	50 80	20 80	-Improved West and Gaeke Method -Ultraviolet Fluorescence
Nitrogen dioxide (NO ₂), µg/m ³	Annual * 24 Hours **	40 80	30 80	-Jacob & Hochheiser modified (NaOH-NaAsO ₂) Method -Gas Phase Chemiluminescence
Particulate Matter (Size less than 10µm) or PM ₁₀ , µg/m ³	Annual * 24 Hours **	60 100	60 100	-Gravimetric -TEOM -Beta attenuation
Particulate Matter (Size less than 2.5µm) or PM _{2.5} , µg/m ³	Annual * 24 Hours **	40 60	40 60	-Gravimetric -TEOM -Beta attenuation
Ozone (O ₃), µg/m ³	8 Hours * 1 Hour **	100 180	100 180	-UV Photometric -Chemiluminescence -Chemical Method
Lead (Pb), µg/m ³	Annual * 24 Hours **	0.50 1.0	0.50 1.0	-AAS/ICP Method after sampling on EPM 2000 or equivalent filter paper -ED-XRF using Teflon filter
Carbon Monoxide (CO), mg/m ³	8 Hours ** 1 Hour **	02 04	02 04	-Non dispersive Infrared (NDIR) Spectroscopy
Ammonia (NH ₃), µg/m ³	Annual * 24 Hours **	100 400	100 400	-Chemiluminescence -Indophenol blue method
Benzene (C ₆ H ₆), µg/m ³	Annual *	05	05	-Gas Chromatography (GC) based continuous analyzer -Adsorption and desorption followed by GC analysis
Benzo(a)Pyrene (BaP) Particulate phase only, ng/m ³	Annual *	01	01	-Solvent extraction followed by HPLC/GC analysis
Arsenic (As), ng/m ³	Annual *	06	06	-AAS/ICP Method after sampling on EPM 2000 or equivalent filter paper
Nickel (Ni), ng/m ³	Annual *	20	20	-AAS/ICP Method after sampling on EPM 2000 or equivalent filter paper

Water Quality Standards

S. No	Parameters	IS:2296 (Class C)	IS:10500	Method Adopted
1	PH	6.5-8.5	6.5-8.5	pH meter
2	BOD (3 days 27°C)	3.0	NS	DO-Azide modification of Winkler's method
3	Temperature (C)	NS	NS	Thermometer
4	Dissolved oxygen	4	NS	Azide Modification of Winkler's method
5	Color (Hazen)	300	NS	Visual Comparison method
6	Fluorides (F)	1.5	1.0(1.5)	SPANDS method
7	Chlorides (Cl)	600	250(1000)	Argentometric Titration
8	Total Dissolved Solids	1500	500 (2000)	Gravimetric Analysis
9	Sulphates (SO ₄)	400	200 (400)	Barium Chloride method
10	Iron (Fe)	50	0.3(1.0)	Phenanthroline method
11	Oil and Grease	0.1	NS	Partition - Gravimetric method
12	Nitrates	50	45 (100)	Chromotropic acid
13	Chromium (Cr ⁶⁺)	0.05	0.05	Atomic Absorption Spectrophotometry
14	Cadmium (Cd)	0.01	0.01	Atomic Absorption Spectrophotometry
15	Lead(Pb)	0.1	0.05	Atomic Absorption Spectrophotometry
16	Copper (Cu)	1.5	0.05 (1.5)	Atomic Absorption Spectrophotometry
17	Cyanide (CN)	0.05	0.05	Chloramine-T-method
18	Selenium (Se)	0.05	0.01	Atomic Absorption Spectrophotometry
19	Arsenic (As)	0.2	0.05	Atomic Absorption Spectrophotometry
20	Phenols	0.005	0.001(0.002)	Spectrophotometer
21	Detergents	1.0	0.2(1.0)	Spectrophotometer
22	DDT	Absent	Absent	Spectrophotometer
23	Total Coliform (MPN/100 ml)	5000	NS	Multiple Tube Fermentation Technique

National Ambient Noise Standards

Area Code	Category of Zones	Limits of Leq in dB(A) Day*	Night*
A	Industrial	75	70
B	Commercial	65	55
C	Residential	55	45
D	Silence Zone **	50	40

Daytime shall mean from 6.00am to 10.00 pm and Night shall mean from 10.00 pm to 6.00 am Silence zone is defined as area up to 100 meters around premises of hospitals, educational institutions and courts.

Use of vehicles horns, loudspeakers and bursting of cracking are banned in these zones.

APPENDIX 9: ENVIRONMENT FRIENDLY CONSTRUCTION METHODOLOGY

The contractor shall be deemed to have acquainted himself with the requirements of all the current statutes, ordinances, by-laws, rules and regulations or their instruments having the force of law including without limitation those relating to protection of the environment, health and safety, importation of labour, demolition of houses, protection of environment and procurement, transportation, storage and use of explosives, etc.

Protection of Environment

- a) The contractor will take all necessary measures and precautions and ensure that the execution of the works and all associated operations on site or offsite are carried out in conformity with statutory and regulatory environmental requirements including those prescribed in EMP.
- b) The contractor will take all measures and precautions to avoid any nuisance or disturbance to inhabitants arising from the execution of works.
- c) All liquid waste products arising on the sites will be collected and disposed of at a location on or off the sites and in a manner that will not cause either nuisance or pollution.
- d) The contractor will always ensure that all existing water courses and drains within and adjacent to the site are kept safe and free from any contamination.
- e) The contractor will submit details of his temporary drainage work system (including all surface channels, washing basins and discharge pits) to the PMC and ESMU for approval prior to commencing work on its construction.
- f) The contractor will arrange all the equipment in good condition to minimize dust, and other air-borne emissions and carry out the works in such a manner as to minimize adverse impact on air.
- g) Any vehicle with an open load-carrying area used for transporting potentially dust-producing material will have properly fitted side and tailboards. Materials having the potential to produce dust will not be loaded to a level higher than the side and tail boards and will be covered with a clean tarpaulin in good condition.
- h) The contractor will take all necessary measures to ensure that the operation of all mechanical equipment and condition processes on and off the site will not cause any unnecessary or excessive noise, considering applicable environmental requirements.
- i) The contractor will take necessary measures to maintain all plant and equipment in good condition.
- j) Where the execution of the works requires temporary closure of road to traffic, the contractor will provide and maintain temporary traffic diversions subject to the approval of the PMC.
- k) Where the execution of the works requires single-lane operation on public road the contractor will provide and maintain all necessary barriers, warning signs and traffic control signals to the satisfaction of the PMC.
- l) Wherever traffic diversions, warning signs, traffic control signals, barriers and the like are required, the contractor will install them to the satisfaction of PMC prior to commencing the work, in that area.
- m) Contractor will install asphalt plants and other machineries away from the populated areas as per laid down regulations.
- n) Permit for felling of trees will be obtained from the forest department before the execution of any work.

- o) Water sprinkling should be provided at appropriate places for preventing dust pollution during handling and stockpiling of stones and loose earth.
- p) Over Burden (OB) waste dumps shall be sprayed with water, as they are the major source of air borne particulate matter.
- q) OB waste dumps shall be reclaimed / afforested to bind the loose soil and to prevent soil erosion. The frequency of sprinkling should be fixed as per the seasonal requirement and in consultation with engineer.
- r) Regular water spraying on haulage roads during transportation of construction material by water sprinklers. The frequency of sprinkling should be fixed as per the seasonal requirements in consultation with engineer.
- s) Transfer point for transporting construction material shall be provided with appropriate hoods/ chutes to prevent dust emissions.
- t) Dumping of construction material should be from an optimum height (preferably not too high), so as to reduce the dust blow.
- u) Innovative approaches of using improvised machinery designs, with in-built mechanism to reduce sound emission.
- v) Procurement of drill loaders, dumpers and other equipment with noise proof system in operator's cabin.
- w) Confining the equipment with heavy noise emissions in soundproof cabins, so that noise is not transmitted to other areas.
- x) Regular and proper maintenance of noise generating machinery including the transport vehicles to maintain noise levels.
- y) Provisions should be made for noise absorbing pads at foundations of vibrating equipment to reduce noise emissions.

Quarry Operations

The Contractor shall obtain materials from quarries only after the consent of the Forest Department or other concerned authorities and in consultation with the Engineer. The quarry operations shall be undertaken within the purview of the rules and regulations in force.

Prevention of Water Courses from Soil Erosion

The Contractor shall apply following mitigation measures to prevent sedimentation and pollution of watercourses.

- To prevent increased siltation, if need be existing bridges maybe widened downstream side of the water body;
- Cement should be stacked fenced by bricks or earth wall, and kept away from water, to prevent leachate formation and contamination of surface and ground water;
- If need be, slope of the embankments leading to water bodies should be modified and rechanneled to prevent entry of contaminants into the water body;

Pollution from hot-mix plants and batching plants

Bituminous hot-mix plants and concrete batching plants shall be located sufficiently away from habitation, agricultural operations. The Contractor shall take every precaution to reduce the levels of noise, vibration,

dust and emissions from his plants and shall be fully responsible for any claims for damages caused to the owners of property, fields and residents in the vicinity.

Arrangement for traffic during construction

The Contractor shall always carry out work on the road in a manner creating least interference to the flow of traffic with the satisfactory execution. For all works involving improvements to the existing state highway, the Contractor shall, in accordance with the directives of the PMC, provide and maintain, during execution of the work, a passage for traffic either along a part of the existing carriageway under improvement, or along a temporary diversion constructed close to the state highway. The Contractor shall take prior approval of the PMC regarding traffic arrangements during construction.

Traffic safety and control

- a) Where subject to the approval of the Engineer the execution of the works requires temporary closure of road to traffic use, the Contractor shall provide and maintain temporary traffic diversions. The diversion shall generally consist of 200 mm thickness of gravel 4.5 meters wide laid directly upon natural ground and where any additional earthworks are required for this purpose that will be provided under the appropriate payment items.
- b) Where the execution of the works requires single-lane operation on public road, the Contractor shall provide and maintain all necessary barriers, warning signs and traffic control signals to the approval of the Engineer.
- c) Except for temporary traffic arrangements or diversions required within the first 4 weeks of the Contract, the Contractor shall submit details of his proposals to the Engineer for approval not less than 4 weeks prior to the temporary arrangement or diversion being required. Details of temporary arrangements or diversions for approval as soon as possible after the date of the Letter of Acceptance.
- d) The color, configuration, size and location of all traffic signs shall be in accordance with the code of practice for road sign. In the absence of any detail or for any missing details, the signs shall be provided as directed by the Engineer (PMC).
- e) The Contractor shall take all necessary measures for the safety of traffic during construction and provide, erect and maintain such barricades, including signs, marking, flags, lights and flagmen as may be required by the Engineer for the information and protection of traffic approaching or passing through the section of the road under improvement. Before taking up any construction, an agreed phased programme for the diversion of traffic or closer of traffic on the road shall be drawn up in consultation with the SE.
- f) At the points where traffic is to deviate from its normal path (whether on temporary diversion or part width of the carriageway) the lane width path for traffic shall be clearly marked with the aid of pavement markings, painted drums or a similar device to the directions of the SE. At night, the passage shall be delineated with lanterns or other suitable light source.
- g) One-way traffic operation shall be established whenever the traffic is to be passed over part of the carriageway inadequate for two-lane traffic. This shall be done with the help of temporary traffic signals or flagmen kept positioned on opposite sides during all hours. For regulation of traffic, the flagmen shall be equipped with red and green flags and lanterns / lights.
- h) On both sides, suitable regulatory / warnings signs as approved by the SE shall be installed for the guidance of road users. On each approach, at least two signs shall be put up, one close to the point where transition of carriageway begins and the other 120 m away. The signs shall be of design and of reflector type, if so, directed by the SE.
- i) Upon completion of the works for which the temporary traffic arrangements or diversions have been made, the Contractor shall remove all temporary installations and signs and reinstate all affected roads and other structures or installations to the conditions that existed before the work started, as directed by the Engineer.

Health and safety

The contractor shall take all measures and precautions necessary to ensure the health, safety and welfare of all persons entitled to be on the site. Such precautions shall include those that, in the opinion of the Engineer, are reasonable to prevent unauthorized entry upon the site and to protect members of the public from any activities under the control of the contractor. The contractor's responsibilities shall include but not be limited to:

- a) The provision and maintenance of the Contractor's Equipment in a safe working condition and the adoption of methods of work that are safe and without risks to the health of any person entitled to be on the site.
- b) The execution of suitable arrangements for ensuring safety and absence of risks to health in connection with the use, handling, storage, transport and disposal of articles and substances,
- c) The provision of lighting, including standby facilities in the event of failure that, in the opinion of the Engineer, is adequate to ensure the safe execution of any works that are to be carried out at right.
- d) The provision of protective clothing and safety equipment, with such personnel and equipment and such information, instruction, training and supervision as are necessary to ensure the health and safety at work of all persons employed on or entering on the site in connection with the works, including the Engineer's supervisory staff, all in accordance with the laws.
- e) Near towns, villages and all frequented places, trenches and foundation pits shall be securely fenced provided with proper caution signs and marked with lights at night to avoid accidents. Contractor shall take adequate protective measures to see that the excavation operations do not affect or damage adjoining structures.
- f) The contractor shall not use or generate any materials in the works, which are hazardous to the health of persons, animals or vegetation. Where it is necessary to use some substances, which can cause injury to the health of workers, the Contractor shall provide protective clothing or appliances to his workers.
- g) The contractor will take all measures necessary to safeguard the health; safety and welfare of all persons entitled to be on site and will ensure that works are carried out in a safe and efficient manner.
- h) The contractor will provide and ensure the utilization of appropriate safety equipment for all workmen and staff employed directly or indirectly by the contractor. Such safety equipment will include but not be limited to the safety helmets, goggles and other eye protectors, hearing protectors, safety harnesses, safety equipment for working over water, rescue equipment, fire extinguishers and first-aid equipment. The personnel working at vulnerable locations at site will wear safety helmets and strong footwear.
- i) The contractor will provide an adequate number of latrines and other sanitary arrangements at areas of the site where work is in progress and ensure that they are regularly cleaned and maintained in a hygienic condition.

First aid

- i) The provision and maintenance of suitably equipped and staffed first aid stations throughout the extent of the works to the satisfaction of the Engineer. The contractor shall allow in his prices and the responsible for the costs of all such site welfare arrangements and requirements.
- ii) Injuries might occur during the construction period. It is therefore pertinent to provide first aid facilities for all the construction workers. At construction camps and at all workplaces first aid equipment and nursing staff must be provided. Since many of the workplaces may be far away from regular hospitals, an indoor health unit having one bed facility every 250 workers needs to be provided.

- iii) Adequate transport facilities for moving the injured persons to the nearest hospital must also be provided in ready to move condition.
- iv) The first-aid units apart from an adequate supply of sterilized dressing material should contain other necessary appliances as per the factory rules.

Maintenance

- i) All buildings, rooms and equipment and the grounds surrounding them shall be maintained in a clean and operable condition and be protected from rubbish accumulation.
- ii) Each structure made available for occupancy shall be of sound construction, shall assure adequate protection against weather, and shall include essential facilities to permit maintenance in a clean and operable condition. Comfort and safety of occupants shall be provided for by adequate heating, lighting, ventilation or insulation when necessary to reduce excessive heat.

Maintenance of diversions and traffic control devices

Signs, lights, barriers and other traffic control devices, as well as the riding surface of diversion shall be maintained in a satisfactory condition till such time they are required as directed by the SE. The temporary traveled way shall be kept free of dust by frequent applications of water, if necessary.

APPENDIX 10: SOIL EROSION AND SEDIMENTATION CONTROL

All materials shall meet commercial grade standards and shall be approved by the Engineer before being used in the work.

Construction operations

Prior to the start of the relevant construction, the Contractor shall submit to the PMC for approval, his schedules for carrying out temporary and permanent erosion/sedimentation control works as are applicable for the items of clearing and grubbing, roadway and drainage excavation, embankment/sub-grade construction, bridges and other structures across water courses, pavement courses and shoulders. He shall also submit for approval his proposed method of erosion/sedimentation control on service road and borrow pits and his plan for disposal of waste materials. Work shall not be started until the erosion/sedimentation control schedules and methods of operations for the applicable construction have been approved by the Engineer.

The surface area of erodible earth material exposed by clearing and grubbing, excavation, borrow and fill operations shall be limited to the extent practicable. The Contractor may be directed to provide immediate control measures to prevent soil erosion and sedimentation that will adversely affect construction operations, damage adjacent properties, or cause contamination of nearby streams or other watercourses. Such work may involve the construction of temporary berms, dikes, sediment basins, slope drains and use of temporary mulches, fabrics, mats, seeding, or other control devices or methods as necessary to control erosion and sedimentation.

The Contractor shall be required to incorporate all permanent erosion and sedimentation control features into the project at the earliest practicable time as outlined in his accepted schedule to minimize the need for temporary erosion and sedimentation control measures.

Temporary erosion/sedimentation and pollution control measures will be used to control the phenomenon of erosion, sedimentation and pollution that may develop during normal construction practices but may neither be foreseen during design stage nor associated with permanent control features on the Project.

Where erosion or sedimentation is likely to be a problem, clearing and grubbing operations should be so scheduled and performed that grading operations and permanent erosion or sedimentation control features can follow immediately thereafter if the project conditions permit; otherwise temporary erosion or sedimentation control measures may be required between successive construction stages. Under no conditions shall a large surface area of erodible earth material be exposed at one time by clearing and grubbing or excavation without prior approval of the Engineer.

The Engineer may limit the area of excavation, borrow and embankment operations in progress, commensurate with the Contractor's capability and progress in keeping the finish grading, mulching, seeding and other such permanent erosion, sedimentation and pollution control measures, in accordance with the accepted schedule.

Temporary erosion is sometimes caused due to the Contractor's negligence, carelessness or failure to install permanent controls. Sedimentation and pollution control measures then become necessary as a part of the work as scheduled or ordered by the Engineer, and these shall be carried out at the Contractor's own expense. Temporary erosion, sedimentation and pollution control work required, which is not attributed to the Contractor's negligence, carelessness or failure to install permanent controls, will be performed as ordered by the Engineer. Temporary erosion, sedimentation and pollution control may include construction work outside the right of way where such work is necessary as a result of road construction such as borrow pit operations, service roads and equipment storage sites.

The temporary erosion, sedimentation and pollution control features installed by the Contractor shall be maintained by him till these are needed, unless otherwise agreed by the Engineer.

APPENDIX 11: WORKERS SAFETY IN COMMON OPERATION AND DURING CONSTRUCTIONS

Housekeeping practices

1. Maintain washrooms and canteens clean
2. Always keep all walkways clear and unobstructed
3. Ensure that spillages of oil and greasy
4. Stack raw materials and finished products clear of walkways or inside roads
5. Do not leave tools on the floor or in any location where they can be easily dislodged
6. Keep windows and light fitting clean
7. Maintain the workplace floors dry and in a non-slippery condition
8. Provide and maintain proper drainage system to prevent water ponding
9. Use metal bins for oily and greasy rags and store all flammable materials in appropriate bins, racks or cabinets. Ensure that the metal bins for storing oily and grease rags should be covered with lids.
10. Ensure that protruding nails in boards or walls are moved or bent over so that they do not constitute a hazard to people
11. Make sure that hazardous/dangerous chemicals are kept in the goods stores with the appropriate labeling, display of the material-safety-datasheet (MSDS) and other precautionary measures
12. Display 'no smoking' signs in areas with high fire risks, e.g. paint stores, wood working area and others

Safe layout in the construction plant, camp and quarry areas

1. Arrange border to perimeter fencing
2. Ensure good visibility and safe access at site entrances
3. Provide adequate warning signs at the entrance and exit where necessary
4. Provide adequate space/area for loading and unloading, storage of materials, plant and machinery
5. Display emergency procedure and statutory notices at conspicuous location
6. Consider welfare facilities required
7. Provide areas for dumping garbage and other waste materials, and also arrange for their regular clearance.
8. Arrange storage, transport and use of fuel, other flammable materials and explosives in line with the license requirements to be obtained from appropriate authorities
9. Plan emergency assembly points, fire escape routes and locate fire-fighting equipment
10. Provide access roads and plant movement areas within the site.
11. Ensure the availability of first aid facilities and display notices at the various works to show the location of these facilities
12. Provide proper drainage and sewage & drainage facilities

Tree felling

1. Use hard hats during tree felling
2. Ensure tools such as the axes are in good condition
3. Determine proper foot and body position when using the axe. Do not cut above your head
4. Wear appropriate foot protection
5. Carry a first aid kit to the site
6. Determine possible hazards in the area, e.g. electrical or telephone or other utility lines
7. Prior to felling, determine the safest direction for the fall
8. Determine the proper hinge size before directing the tree fall.

Noise hazards and its control

Note that indications of noise levels are:

- You have to shout to be heard;
 - Your hearing is dulled just after work;
 - You get head noises or ringing in the ears after work;
 - You have difficulty hearing people while others are talking
1. Use sound level meters to measure. If the sound level exceeds 85 dB(A), then preventive measures should be taken
 2. Make personnel aware of noisy areas by using suitable warning signs and insisting that ear protectors should necessarily be worn.
 3. Reduce noise at source by improved maintenance, replacing noisy machines, screening with noise absorbing material, making changes to the process/equipment, controlling machine speeds, ensuring that two noise-generating machines are not running at the same time, using cutting oils and hydraulic breakers.
 4. Appoint a competent person to carry out a detailed noise assessment of the site, designate ear protection zone, and give instructions on the necessary precautionary measures to be observed by site personnel, including the use of suitable type of ear protections.
 5. Wear and maintain earmuffs and ear plug as required
 6. In construction or repair work, noise should be kept to a low-level bearing in mind the disturbance to residents.

Road works

1. The use of signage is most important to caution the road users of possible unsafe conditions due to the road works.
2. Use the appropriate signage devices as required by the site conditions/situation. The devices include regulatory signs, delineators, barricades, cones, pavement markings, lanterns and traffic control lights.
3. In using signs, make sure that they are (i) simple, easy-to-understand and convey only one message, (ii) luminescent and with reflective properties, and iii) broad, prominent and of appropriate size.
4. In using barricades, make sure that you keep traffic away from work areas and you guide the drivers to keep along a safe, alternative path.

5. Ensure that proper personal protective equipment (PPE) is provided to all the workers.
6. Cover existing road signs and install new ones at appropriate locations taking into account the distances that would be required and reaction times.
7. Plan layout and traffic management so that hazard is not created.
8. Deploy flagmen, who control traffic at the work areas. The flag should be 600mm x 600mm fastened to a 1m length staff.
9. Flagmen should wear reflective safety vests along with hard hats
10. If required, use wireless devices for flagmen to co-ordinate from either ends of the road, where works are being carried out.

Electrical hazards in construction areas

1. Treat all wires as live wires
2. Never touch dangling wires, but report them to your manager
3. Unless you are a qualified electrician, do not attempt electrical repairs
4. Never use electrical equipment if your hands are wet or you are standing in water
5. If electrical equipment is sparking or smoking, turn the power off and report the condition to your supervisor
6. Never use electrical wires that have physical damage
7. Never allow equipment or traffic to run over electrical wires.

Use and storage of gas/lpg

1. Store filled gas/LPG cylinder in the open area, i.e. outside of the building
2. Transport, store, use and secure cylinders in upright position
3. Ensure proper ventilation at the ground level in locations where gas/LPG is in use
4. Avoid physical damage to the cylinders
5. Never weld or cut on or near the cylinders
6. Store empty cylinders secured and upright
7. Make sure that the cylinder is closed immediately after use
8. Investigate immediately if there is the smell of LPG or gas
9. Never use de stanching gas/LPG on site.
10. Make sure that there is no other unrelated fire in the vicinity of the cylinder

Operation of excavators

1. Ensure that excavators are operated by authorized persons who have been adequately trained.
2. Prevent unauthorized movement or use of the excavators
3. Check regularly and maintain the machine thoroughly
4. Ensure that all relevant information, including those related to instruction, training, supervision and safe system of work are provided to the operators.

5. Ensure that the operation and maintenance manuals, manufacturer's specifications, inspection and maintenance logbooks are provided for the use of the mechanics, service engineers or other safety personnel during periodic maintenance, inspection and examination.
6. During tipping or running alongside the trenches, excavators must be provided with stop blocks.
7. Excavators must be rested on firm ground during operation
 1. Avoid operating the machine too close to an overhang, deep ditch or hole and be alert to potential carving edges, falling rocks and slides, rough terrain and obstacles.
 2. Locate and identify underground services by checking with all utility companies before excavations.
 3. Ensure that all excavations are supervised by experienced and competent persons.
 4. When reversing or in case the operator's view is restricted, adequate supervision and signaling should be provided.
 5. Ensure that the type and capacity of the excavator are properly chosen for the intended purposes and site conditions. Never use a machine for any purposes other than it is designed for.
 6. Check and report for excessive wear and any breakage of the bucket, blade, edge, tooth and other working tools of the excavator.
 7. Check that all linkages/hinges are properly lubricated and ensure that the linkage pins are secured. Never use improper linkage pins.
 8. Never dismount or mount a moving machine
 9. Work only with adequate ventilation and lighting
 10. Ensure that the protective front screen of the driving cabin is fixed in position during excavations to avoid eye injury to the operator.
 11. Ensure switch-off of the unattended vehicle.

Operation of trucks and dumpers

1. Ensure that only trained, authorized and licensed drivers operate the vehicles
2. Enlist the help of another worker before reversing the vehicle
3. Switch-off the engine of an unattended vehicle
4. Lower the tipping bodies when the machine is unattended, but if it is necessary to leave them in the raised position, they should be blocked to prevent their fall.
5. Wear safety boots or shoes to avoid injuries during loading and unloading.
6. Carryout periodic servicing to the manufacturer's requirements. All records of maintenance and repairs should be in writing or kept on site.
7. Keep the vehicle tidy and the cabin free from tools and material, which might obstruct the controls.
8. Keep to speed limits.
9. No passenger should be carried on a dumper except the driver
10. Never drive the vehicle across a slope
11. Provide stop blocks when the vehicle is tipping into or running alongside excavations

12. Do not overload the vehicle.
13. Carry only well secured loads
14. Park only on level ground, in neutral with the parking brake applied
15. Never mount or dismount from a moving vehicle

Gas welding

1. Use the following personal protective equipment during welding
 - Face or hand shield fitted with filters
 - Goggles, particularly when chipping slag
 - Gloves long enough to protect wrists and forearms against heats, sparks, molten metal and radiation
 - High-top boots to prevent sparks from entering footwear.
2. Screen of the work area with sturdy opaque or translucent materials because glare can cause eye injury.
3. Key for opening the acetylene cylinder valve must be on the valve stem while the cylinder is in use so that the cylinder valve may be immediately shut-off in an emergency.
4. Ventilate the workplace using air blowers and exhaust fans to remove poisonous fumes and gases that are given off during welding
5. Take precautions against flying sparks and hot slag where welding is being done near flammable materials and check the area before leaving.
6. Do not weld material degreased with solvents until completely dry.
7. Do not use gas cylinders for supporting work or as rollers
8. Do not use oil grease on oxygen cylinder fittings
9. Do not use cylinders with damaged valves.
10. Do not use too much force if valves are stuck.
11. Replace valve caps after use
12. Search for leaks in equipment by using a solution of soapy water.
13. Shut the cylinder valve if acetylene from a cylinder catches fire at the valve or regulator due to leakage at a connection.
14. Treat all gas cylinders as “full” unless you are sure otherwise.
15. Never attempt to transfer acetylene from one cylinder to another or attempt to refill an acetylene cylinder.
16. Place portable fire extinguishers near the welding area
17. Secure all cylinders against accidental displacement.
18. Always lift gas cylinders. Do not slide them along the ground or drop them from trucks.
19. Keep gas cylinders in vertical position both in storage and when in use
20. Keep the workplace dry, secure, free from combustible materials and obstruction.
21. Store the acetylene and oxygen cylinders separately, and in a proper store.
22. Keep the gas cylinders from source of heat, flammable materials, corrosive chemicals and fumes.

Manual handling and lifting

1. Use mechanical equipment in place of manual handling as far as possible.
2. Assess the manpower required to handle or lift the load safely and arrange the manpower accordingly.

3. In handling hazardous materials, the workers shall be informed of the hazards and safety precautions.
4. All relevant persons shall be trained in the proper methods of lifting and carrying.
5. Where teamwork is required, select the persons whose ages and physical builds are compatible for teaming up. Coordinate the actions of the team members by giving necessary instructions.
6. Always lighten or suitably shape the load for manual handling as far as possible. Keep a look out for splinters, sharp edges, loose banding and nails.
7. Clear path or obstruction and tripping hazards.
8. Stack and secure goods safely on trucks, otherwise they fall off and injure passers-by.
9. Use personal protective equipment such as gloves, safety shoes, etc.
10. Adopt the following procedure when you lift a load:
11. Stand close to the object. Have a firm footing with feet spread on either side of the road.
12. Bend the knees and keep your back as straight as you can
13. Grasp object firmly. Be sure grip will not slip
14. Breathe in and throw the shoulder backwards.
15. Straighten the legs, continuing to keep the back as straight as you can.
16. Hold object firmly close to the body
17. Always lift smoothly. Avoid jerky motions. Turn with feet instead of twisting the back.

Handling chemicals and hazardous substances

1. Always substitute hazardous chemicals with harmless or less hazardous ones wherever possible.
2. Enclose the process using chemicals or provide other engineering controls such as local exhaust ventilation, a fume cupboard or a safety cabinet.
3. Exercise great care in the storage and use of chemicals because they may be explosive, poisonous, corrosive or combustible.
4. Separate different chemicals physically
5. Store chemicals classified as dangerous goods in a properly constructed and approved goods store. Keep proper records of all chemicals and hazardous substances delivered, stored and used on site.
6. Consider unknown substances and liquids as dangerous until proven otherwise.
7. All containers should be clearly labelled to indicate contents. Never use a wrongly labelled container for chemicals.
8. Prohibit smoking in the vicinity of dangerous chemicals
9. Ensure that you are wearing the correct personal protective equipment before you handle chemicals
10. Maintain the Material Safety Data Sheet of all chemicals for reference on safety precautions to be taken and the use of suitable PPE.
11. When opening containers, hold a rag over the cap or lid, as some volatile liquids tend to spurt up when released.

12. Wash before you eat and do not eat at the workplace.
13. If the skin is splashed with a chemical, rinse it immediately with plenty of clean water. Eye should be flushed thoroughly with water followed by immediate medical attention.
14. Eye fountain, emergency shower and breathing apparatus should be available in the vicinity of the workplace.
15. Safety instructions for handling emergency situations should be displayed prominently at both the storage and use locations.

First aid

1. Provide first aid boxes at every site
2. Ensure that training on the use of the first aid box is provided to a handful of staff working in the site.
3. Display the list of persons who are trained on providing first aid.
4. Ensure that every first aid box is marked plainly “First Aid” in English and local language.
5. The responsible person or first aider should replenish the contents of the first aid box as necessary.

Personal protective equipment

General

1. Consider the provision of personal protective equipment only after all measures for removing or controlling safety hazards have been provided reasonably impractical.
2. Ensure that enough personal protective equipment is provided and that they are readily available for every person who may need to use them.
3. The management should ensure that all persons make full and proper use of the personal protective equipment provided.
4. Provide instruction and training in the proper use and care of any specific protective equipment where necessary
5. Do not willfully misuse, interfere with or ill-treat any protective clothing and equipment provided.
6. Ensure that the personal protective equipment is in good condition. Report immediately any damage to the management for replacement. Always keep the personal protective equipment as clean as possible.

Eye protection

1. Issue eye protection equipment where there is a foreseeable risk of eye injury
2. Ensure an adequate supply of goggles/shields is available.
3. Keep the goggles clean and make sure they are good fit.
4. Do not watch welding operations unless your eyes are protected from the damaging effect of flash.

Head Protection

1. No person shall enter a construction site unless he is wearing a suitable safety helmet
2. Wear a safety helmet:
 - When there is the risk of being hit by falling objects
 - While on or near a construction site
 - During adverse weather conditions
 - When in any area designated as a “hard hat” area.
3. Provide identification labels to all helmets in some way to prevent random exchange among wearers, with one helmet exclusive to each person.
4. Inspect helmets for cracks or sign of impact or rough treatment before each usage. Destroy, remove and replace all worn, defective or damaged helmets.

Hearing Protection

1. Provide ear plugs or earmuffs as required. Use re-usable ear plugs when the reduction required (15-25 dBA) is not excessive. Use earmuffs where a large attenuation of upto 40 dBA is demanded.
2. Do not use dry cotton wool for hearing protection because it cannot provide any.
3. Provide disposable ear plugs for infrequent visitors and ensure that they are never re-used.
4. Provide re-usable ear plugs for those who need to work continuously for a long period in a high noise area.
5. Use earmuffs with replaceable ear cushions because they deteriorate with age or may be damaged in use.
6. Avoid wearing spectacles with earmuffs.
7. Use soap and water or the recommended solvent for cleaning earmuffs.
8. Provide earmuffs for those who may need to get in and out of a high noise area frequently.

Respiratory protective equipment

1. Wear suitable repairable for protection when there is a potential for small particles entering the lungs, e.g. emptying of cement bags.
2. Provide training to all persons using the respirators for their correct fitting, use, limitations and symptoms of exposure.
3. Clean and inspect all respirators before and after use.
4. Store respirators properly when not in use.

Safety Footwear

1. Wear suitable footwear for work
2. Use safety footwear on site or in other dangerous areas
3. Wear suitable safety shoes or ankle boots when working anywhere where there is high risk of foot injuries from slippery or uneven ground, sharp objects, falling objects, etc.
4. All safety footwear, including safety shoes, ankle boots and rubber boots, should be fitted with steel toecaps.
5. Avoid wearing flip flops, high heeled shoes, slippers, light sport shoes in situations where there is a risk of foot injury.
6. Keep shoelace knots tight.

Hand Protection

1. Wear suitable gloves for selected activities such as welding & cutting and manual handling of materials & equipment.
2. Do not wear gloves where there is a risk of them becoming entangled in moving parts of machinery
3. Wash hands properly with disinfectant soap and clean water before drinking, eating or smoking. Wash hands immediately after each operation on site when the situation warrants.

Fire prevention, fighting and equipment

1. Before fire breaks cut
2. Store flammable material in proper areas having adequate fire protection systems.
3. Display sufficient warning signs.
4. Train selected personnel to use these fire extinguishers
5. Inspect fire extinguishers regularly and replace as necessary
6. Fire escape route should always be kept clear and clearly indicated.
7. Know the escape route and assembly point.
8. Display escape route maps prominently on each floor
9. Carryout fire drill regularly. Designate fire officers
10. Install fire alarm wherever required and test regularly.
11. Provide sufficient exit signs at prominent locations for directing people to the escape staircases and routes.

When fire breaks out

1. Alert all persons
2. Put off the fire with appropriate fire extinguishers only when you are sure that you are safe to do so.
3. Escape if you are in danger through the fire escape route to assembly point
4. Fire officers to carryout head count at the assembly point.

Incident and accident investigations

1. Carryout the investigation as quickly as possible.
2. Conduct interviews with as many witnesses as necessary
3. Do not rely on any one sole source of evidence
4. Use the following tools:

Checklists for obtaining basic and typical information for accidents

- Notebook
 - Tape records
 - Camera
 - Measuring tape
 - Special equipment for the particular investigation
5. Obtain answers to the following questions:
 - When did the accident occur?
 - Where did it occur?
 - Who was injured and what was damaged?
 - What caused the accident?
 - Why did it occur?
 - How could it have been prevented?
 - How can a recurrence be prevented?
 6. Prepare a short but sufficient investigation report that contains the following:
 - A summary of what had happened
 - A summary of events prior to the accident
 - Information gathered during the investigation
 - Details of witnesses
 - Information on injury or loss sustained
 - Conclusions and possible causes of the accident
 - Recommendations to prevent recurrence
 - Supporting materials (photos, diagrams, etc.)

Guidelines for workers safety during construction

S. No	Stage and Nature of Construction Hazard	Safety measures expected to be taken by the Contractors and Site Engineers
1	Excavation in soft loose & slushy soil above 2.00 m depth sliding of earth or collapsing of sides.	The Excavation beyond 1.5 m to 2.00 m to be done in steps of minimum 500 mm offsets as shown in Clause 2.18.2(b) and also planking and strutting should be done as in Clause 2.19.1.
2	Excavation in slippery area (waterlogged) – The labour may fall or machinery on site may slip.	Try to dewater the area and spread minimum 150 mm thick sand layer to avoid slipping
3	Excavation in Rock where chiselling is involved – The fall of hammer may injure the hand; small rock pieces may injure the eyes and legs.	For hammer work, only experienced and skilled labour should be employed. Chisel should not be allowed to be held by hand, while hammering but chisel holding clamp should be provided. The labour should be provided with goggles and leg cover to protect eyes and legs, from injuries due to small rock pieces.
4	Excavation in Rock where blasting is involved - Careless handling may lead to injury to main worker or a passer-by.	The work of blasting should be entrusted to only experienced persons. Provide enough length of fuse to give ample margin of time from the time of lighting to the time of explosion. A danger zone at

S. No	Stage and Nature of Construction Hazard	Safety measures expected to be taken by the Contractors and Site Engineers
		least 180m diameter is to be flagged off 10 minutes before actual firing. All workmen should be sent away from danger zone except the firing man, who should be provided with a whistle.
5	Excavation for drain across road or manhole adjacent to a road – chances of a passer by falling into the excavated portion	The area should be well barricaded & a red lamp provided at night. A watchman should be deputed to prevent any movement of persons, or vehicles.
6	During Excavation or sometimes even while concreting – Snake bites or Scorpion stings –	In places where the movement of snakes are more the contractor should provide the labour with gum boots, gloves etc. and make snake antidotes available on site. A particular care that must be taken on such site is to always keep a vehicle available on site to rush the patient to a doctor. This applies to snake stringed patients as well.
7	Centring (formwork) and scaffolding – Formwork collapse while concreting or just before concreting especially when wooden bellies are used.	Many a times bellies joined give way due to weak joint. Hence the use of joined bellies should be restricted. Only 2 joined bellies out of 8 bellies should be allowed. In case of double staging for a Slab at a height, utmost care should be taken to see that the top belly rests on the bottom belly. A particular care that should be taken during each concreting operating of slabs and beams is that, one carpenter and two helpers with spare bellies, nails etc. should be deputed below the slab/beam that is being concreted to watch any disturbance in the supports of the form-work below during concreting and in case of any doubt the concreting should be stopped immediately and the form work strengthened. Never allow bricks below a belly to make up the required height. This is most dangerous.
8	Formwork for beams and slabs: The bottom of beam collapses and many a times brings down the slab as well, injuring the labour and supervision staff.	This case is noticed when slender bellies are used without bracing. In fact, no concreting should be allowed without bracing at 300 mm above ground, and at mid-way, in normal beams & slabs. The bracings should be for the support of beams as well as slabs.
9	Formwork for sides of a slab–The labour just rests his foot on the plank and loses balance and falls resulting a fatal accident.	This is noticed when the carpenter fixes the side shuttering of a slab with a plank just tied by binding wire to the steel reinforcements and by wooden pieces nailed in wall and plank. This is so weak a portion that with little pressure the plank gives way. Hence side shuttering should be done with a direct belly support from ground or floor, and the practice of tying planks with binding wire to the steel reinforcement should be totally avoided. A temporary railing along the periphery of slab will guard the life of labour and supervision staff.
10	Formwork for beams and slabs–Opening the form- work–Accident due to fall of materials during removing the forms.	In fact, this is a most dangerous work. One should be very careful while formwork is removed. Only trained carpenters should be deputed for the work. A safe resting place outside the area of slab as a temporary measure should be constructed from where the Slab can be removed safely. Removal of formwork during night should not be permitted under any circumstances.
11	Scaffolding–Fall of workman, Supervision Staff, Standing on Chalis not tied properly or tied only at one end. (Chalis mainly made of Bamboos).	This is a very common negligence on the part of labour who do scaffolding work. The Chalis on which they work either span over its complete length or is tied loosely and many a times at one end only. Hence, care must be taken that the Chali do not span over the full length, but some middle support should be provided and also the same is tied properly on both ends.
12	Ladders–Balli or bamboo ladders – The horizontal member breaks and the person falls. Sometimes the top face just rests on wall and the whole ladder tilts causing an accident.	The ladders should be strong enough to bear the weight of a labour with materials on head. As far as possible a handrail should be provided at one end. The horizontal member should be preferably fixed with Bolt & nuts or strong nails. When the ladder is placed across a wall the top portion should be tied firmly to a strong support so that the ladder does not move laterally.
13	Column Reinforcements–Column	The tendency of bar-benders is to tie the vertical steel with coir rope

S. No	Stage and Nature of Construction Hazard	Safety measures expected to be taken by the Contractors and Site Engineers
	reinforcements mainly in independent footings collapses – Injury to persons working nearby.	or 8 mm steel rods as ties on all four sides of the column reinforcement. This method of supporting the column reinforcements results in a weak support. Hence, the column reinforcements should be supported by strong bellies on all four sides of reinforcements and as far as possible a combined platform should be constructed out of bellies over which the reinforcements can be supported.
14	Concreting chajjas – When chajjas are concreted without care and on opening the formwork the chajja would collapse, causing injury to labour on top or bottom of chajja.	While concreting chajjas care must be taken that the labour does not stand on the reinforcement and disturb the position. Separate scaffolding must be tied over which the labour can stand and work without disturbing the reinforcements. The main reason is in chajja the steel is placed on top face but if the labour stands on the steel, it will bend and come to bottom face and hence the chajja will fall when form-work is removed, thus, causing injury to labour working on top, or bottom.
15	Dismantling–Dismantled materials may fall on passer-by or the person engaged in dismantling work may fall due to slipping. The dismantled materials may fall on persons working below.	When work of demolition is to be taken up the area should be closed for all outsiders. No one should be allowed up to 50 m. from the place of demolition. The workers engaged in demolition should be asked to wear safety belts. Helmets must be worn by all the workers engaged in dismantling work. The place should be strictly guarded at night with red lights at prominent places, and watchman should be posted.
16	Electric-Connections/Cables etc. –High tension/L.T. Electric wire passing near the slab structure- while bending, lifting or tying reinforcements the bar benders may sustain the Electric Shock, causing fatal injury.	The work in such places should not be allowed to the workers themselves, but in such position the work must be executed under the strict supervision of a responsible Foreman or a Supervisor.
17	Electric Connections/Cables etc. –Cables below ground may get punctured during excavation & thus electrocute the labour working. Similarly, when concreting is in progress the punctured cable may prone to be fatal to the labour.	Before taking up the work all available drawings should be studied, local enquiry to be made to know the position of cables and work in such area should be got executed under strict supervision of an experienced Foreman or a Supervisor.
18	Electric Connections/Cables etc. – Temporary Electric lines near damp walls, near joinery stretched on a considerable length – There is every chance that the wire may get cut due to usage and may develop short circuits/leakages etc. and may electrocute the person touching the wire accidentally.	The Electric wires should be maintained by an electrician who should regularly check-up the insulation of wires especially placed near steel items & damp areas. The temporary wiring should be supported properly. As far as possible a good quality wire should be used, this may not get damaged easily.
19	Electric and gas welding work – Drilling, polishing work – Done by temporary cables used on a number of works – Due to the fact that the wires are old & when they come in contact with water even in the process of curing the surrounding area may get affected due to leakage in the electric current thus causing damage to the workers & supervision staff.	All wiring works to be inspected by experienced electrician. All wires to be properly insulated and fixed at height on temporary poles. No welding work should be permitted near damp area. The welders to be provided with welder's goggles & gloves. As far as possible machine in good condition should be used.
20	Construction Machinery & Lifts – Concrete Mixers – Safety precautions. A mixer with hopper tried to be operated by a helper could not release brake in time thus causing injury to the person near hopper- sometimes fatal one.	The Mixers with hopper should be operated by an experienced mixer operator and such mixers should not be allowed to be handled by a helper or a labour.

S. No	Stage and Nature of Construction Hazard	Safety measures expected to be taken by the Contractors and Site Engineers
21	<p>Construction Machinery & Lifts - Lifts - Safety precautions.</p> <p>(1) The lift pit if left unguarded the children of workers may fall in the pit resulting in fatal accident</p>	<p>(1) A brick protection wall of minimum 1.00 m height should be constructed around the Lift Pit, thus, preventing the children going near the pit. A special care should be taken to see that the children are not allowed to come near the machinery.</p>
	<p>(2) The manually operated brakes of the lift failed or the communication between the labour at the top and the liftman failed and thus, the lift was not controlled and resulted in fatal accident.</p>	<p>(2) The condition of the lift must be maintained properly. The lift operator should be well trained. The labour receiving the bucket at top should be smart and active enough to convey the message of stopping & releasing the lift-to-lift operator properly.</p>
22	<p>Water Storage Tank for general use & curing - chances of children of workers falling in the tank with fatal accident.</p>	<p>The water tanks constructed on site should be protected by at least 1.00 m high walls on four sides, so that the children do not fall.</p>
23	<p>Misuse of lift by labour and sometimes supervision staff the lifts that are meant for lifting materials used by labour to go to upper floors – The labour thus traveling many a times get injured.</p>	<p>No person should be allowed to go to upper floors by lifts that are mainly meant for conveying the building materials. Fatal accidents have taken place due to above action of workers.</p>
24	<p>Site Cleaning–Cleaning top floors of buildings – Upper portion of any structure – Throwing waste materials broken concrete pieces, brick bats, sand etc. straightway from top to ground injuring person below or even a passer-by.</p>	<p>This dangerous practice should not be allowed at all. The materials should be brought to the ground with the help of lift or the use of rope over pulley with a bucket, thus bringing down materials safely.</p>
25	<p>Bar bending work-Helpers of bar benders to follow short cut method, throw surplus steel pieces from top floors to ground and may cause fatal injuries.</p>	<p>This is a very bad practice. The helpers should bring the rods to ground with the help of lift or rope & pulley.</p>

APPENDIX 12: STORAGE HANDLING, USE AND EMERGENCY RESPONSE FOR HAZARDOUS CHEMICALS

A1. REFUELING/MAINTENANCE PROCEDURE

- Truck or suitable containers will bring in all fuel and fluids. There will be no storage of fuel, oil or fluids within 100m (or 50m) of the permanent water line.
- Prior to re-fueling or maintenance, drip pans and containment pans will be placed under the equipment. Absorbent blankets may also be required to be placed under the equipment and hoses where there is a possibility of spillage to occur.
- All used oils or fluids will be properly contained and transported to appropriately licensed (authorized) disposal facilities;
- Following re-fueling and maintenance, the absorbent blankets (if any) and spill pans will be picked up and the fuel truck or container moved outside of the 100m (or 50m) wide area.

Emergency Spill Procedure

Should a spill occur, either through spillage or equipment failure, the applicable emergency spill procedure outlined in sections A-2 to A-4 must be followed.

A2. SPILL PROCEDURE (INSIDE THE STREAM)

In the case of a spill, overflow or release fluid into the stream waterway (whether water is flowing during the spill or not), do what is practical and safely possible to control the situation, then get help.

- **Stop the flow**
 - Stop the release into the stream waterway
 - Shutdown equipment
 - Close valves and pumps
 - Plug hoses
- **Remove Ignition Sources**
 - Shut off vehicles and other engines
 - Do not allow tiger torches, vehicles, smoking or other sources of ignition near the area. Keep a fire extinguisher on hand but keep it a safe distance away from the potential ignition source (if a fire starts, the extinguisher must be easily accessible).
- **Contract the environmental Officer and initiate Emergency Response**
 - Notify the site supervisor and the Contractor's Environmental Officer as soon as possible
 - The Environmental Officer will review the situation and decide if Emergency Services like Fire Brigade are required
 - Appropriate parties to be notified of the spill are
 - The contractor's Project Manager
 - The Engineer through his designated Environmental Officer
 - The Client
 - Regulatory Agencies like Pollution Control Board, Municipal Authorities, as applicable.
 - Site Safety Officer

- **Cleanup and Disposal**
 - Emergency Services will be engaged for the containment, cleanup and disposal of contamination release into the environment
- **Reporting**
 - The contractor's Environmental Officer will document the event and submit reports to the Engineer, the Client and appropriate regulatory agencies like the Pollution Control Board (s).
- **Procedure Review**
 - The Engineer will review the report, determine if changes are required to procedures and recommend implementation of all required changes....

A3. SPILL PROCEDURE (ON LAND)

In the case of a spill, overflow or release fluid onto land, do what is practical and safety possible to control the situation, and then get help.

- **Stop the flow**
 - Stop the release into the water body
 - Shut down equipment
 - Close valves and pumps
 - Plug hoses
- **Remove Ignition Sources**
 - Shut off vehicles and other engines
 - Do not allow tiger torches, vehicles, smoking or other sources of ignition near the area. Keep a fire extinguisher on hand but keep it a safe distance away from the potential ignition sources (if a fire starts the extinguisher must be easily accessible).
- **Contain the Spill**
 - Dike around the spill to contain the material
 - Spread absorbent or place a spill blanket on the spill
 - Enlist the help of personnel on site
 - Notify your supervisor as soon as possible
- **Notification**
 - Appropriate parties to be notified of the spill are:
 - The Contractor's Project Manager
 - The Engineer through his designated Environmental Officer
 - The Client
 - Regulatory Agencies like Pollution Control Board, Municipal Authorities, as applicable
 - Site Safety Coordinator
- **Cleanup and Disposal**
 - The Engineer's Environmental Officer will ensure that a proper cleanup and disposal method is determined.

- **Reporting**
 - The Contractor's Environmental Officer will document the event and submit reports to the Engineer, the Client and appropriate regulatory agencies like the Pollution Control Board (s).
- **Procedure Review**
 - The Engineer will review the report, determine if changes are required to procedures and recommend implementation of all required changes.

A4. SPILL PROCEDURE (WITHIN PONDS)

In the case of a spill, overflow or release fluid due to equipment or hose failure, do what is practical and safely possible to control the situation, then get help

- **Stop the flow**
 - Stop the release
 - Shut down equipment
 - Close valves and pumps
 - Plug hoses
- **Remove Ignition Sources**
 - Shut off vehicles and other engines
 - Do not allow tiger torches, vehicles, smoking or other sources of ignition near the area. Keep a fire extinguisher on hand but keep it a safe distance away from the potential ignition sources (if a fire starts the extinguisher must be easily accessible).
- **Contain the Spill**
 - Stop any pumps that may be moving the water from the area where the spill occurred
 - Enlist the help of personnel on site
 - Notify your supervisor as soon as possible
- **Notification**
 - Appropriate parties to be notified or the spill are:
 - The Contractor's Project Manager
 - The Engineer through his designated Environmental Officer
 - The Client
 - Regulatory Agencies like Pollution Control Board, Municipal Authorities, as applicable
 - Site Safety Coordinator
- **Cleanup and Disposal**
 - The Engineer's Environmental Officer will ensure that a proper cleanup and disposal method is determined. Absorbent pads will soak up the spilled material. The pads will be contained and removed from site for disposal at a licensed (authorized) facility.
- **Reporting**
 - The Contractor's Environmental Officer will document the event and submit reports to the Engineer, the Client and appropriate regulatory agencies like the Pollution Control Board (s)
- **Procedure Review**
 - The Engineer will review the report; determine if changes are required to procedures and recommend implementation of all required changes.

APPENDIX 13: ENVIRONMENT COMPLIANCE CERTIFICATE

Project Name:

Date of Inspection.....

S. no	ESMP Provisions	Status		
		Unsatisfactory	Moderately satisfactory	Satisfactory
1	Provision of a personnel accountable for implementation of ESMP / Safety Measures with Contractor			
2	Consent of PCB to Establish HMP			
3	Consent of PCB to operate HMP			
4	Compliance of PCB Conditions for HMP installation and operation			
5	Whether compliance reported through monthly Progress report of Divisional Office of Executive Engineer			
6	PUC taken for all Construction Vehicles			
7	Concrete platform with trap bitumen boiler, Fuel Tank for HMP and generator set provided or not			
8	Precautions to prevent contamination of soil by emulsion, Bituminous, oil and lubricant taken while storing			
9	Providing cover to fine construction material & bituminous mix during transportation			
10	Borrow Areas:			
a	Borrow areas approved by department			
b	Existing land use			
c	Nos Opened			
d	Available Quantity			
e	Balance Quantity			
f	Nos of Borrow areas Rehabilitated			
11	Spoil and debrs disposal:			
a	Existing land use			
b	site approval status			
c	Closure and completion plan			
d	Current status			
12	Site specific traffic Safety management Plan:			
a	Contractor installed the warning / regulatory Traffic signs at the construction sites			
b	Is the arrangement adequate			
13	Safety equipment i.e. helmet, gloves, gumboot, mask, earplugs etc. provided to workers			

Project Name:

Date of Inspection.....

S. no	ESMP Provisions	Status		
		Unsatisfactory	Moderately satisfactory	Satisfactory
14	Health Facility at camp and worksite i.e. First Aid kit & suitable vehicle for conveyance in case of emergency / accident			
15	Provision of labour camp with adequate sanitation & potable water facilities			
16	was sprinkling done to suppress dust			
17	Consent to establish / operation of crusher			
18	Fire precautions at Hot Mix Plant and site office			
19	Was Monitoring of environmental attributes done as per ESMP			
20	Status of drainage provision in camp area			
21	General House Keeping			

Environment Specialist

PMC (Project Management Consultant)

Executive Engineer

CMU (Construction Management Unit)

APPENDIX 14: SEPTIC TANK AND OIL INTERCEPTOR

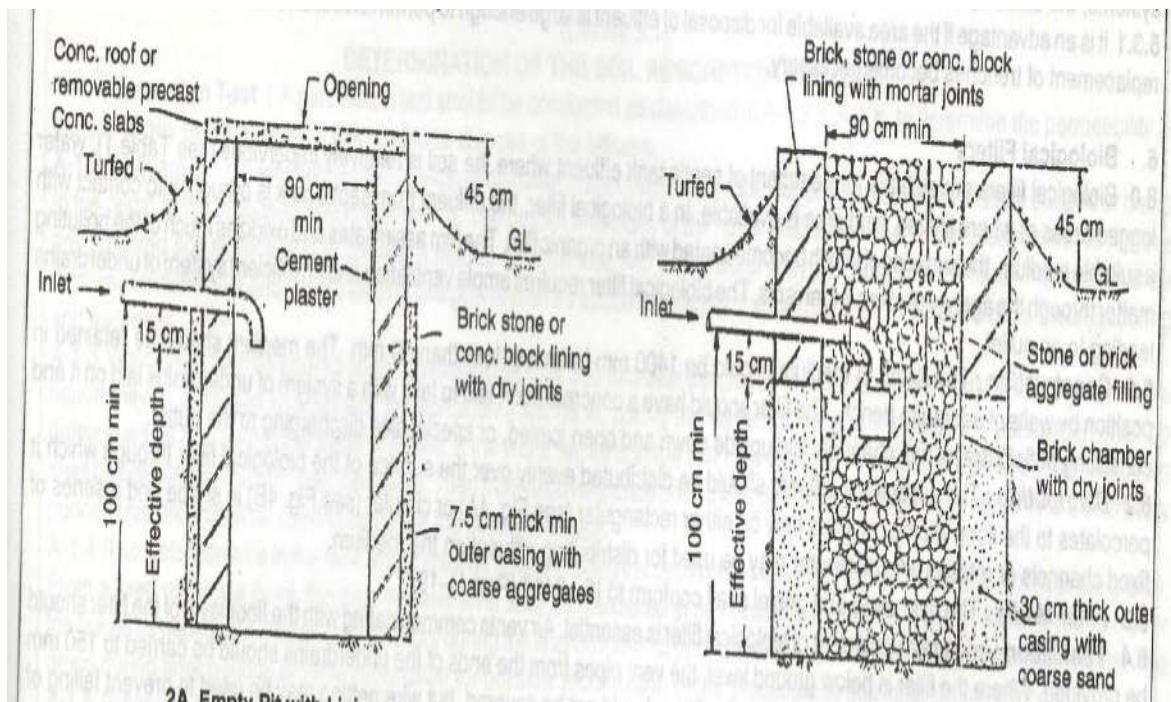
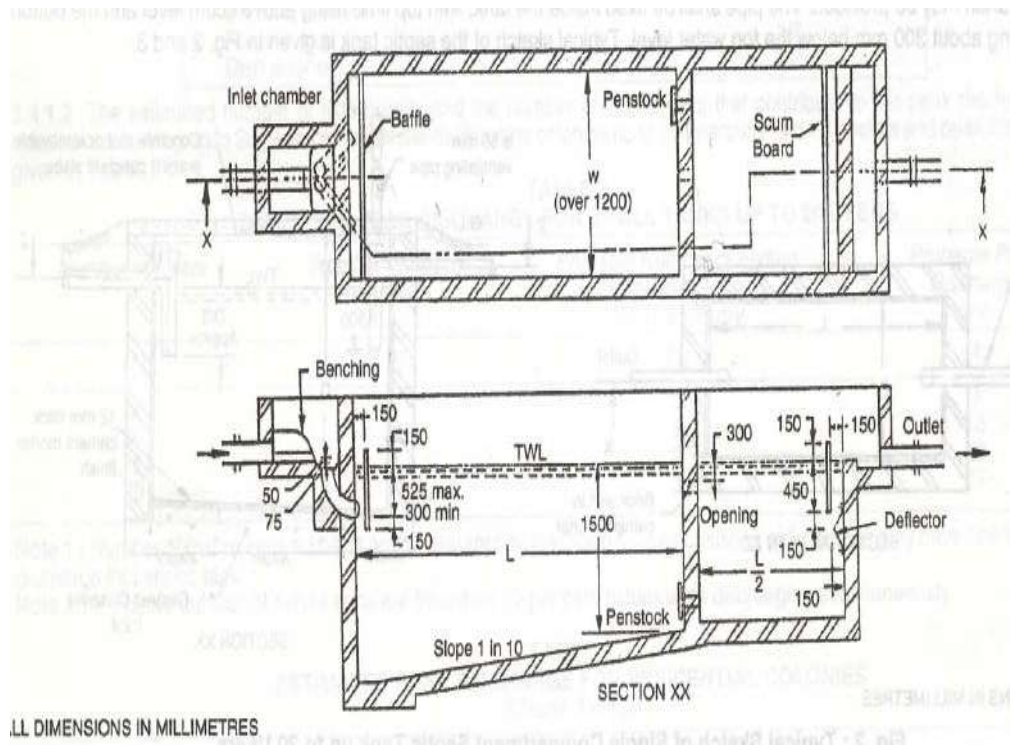

Figure. Septic Tank Specifications

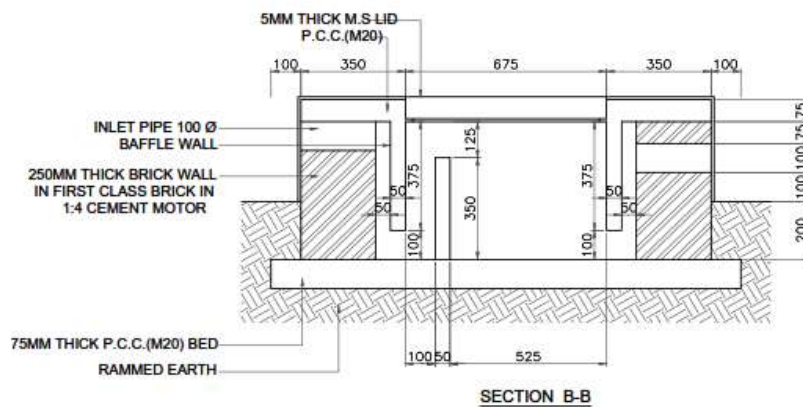
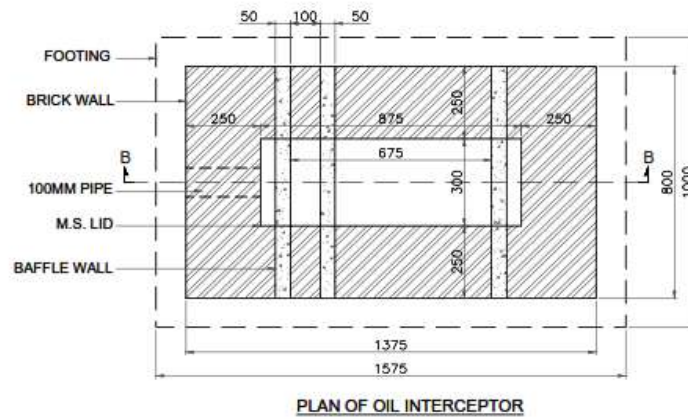
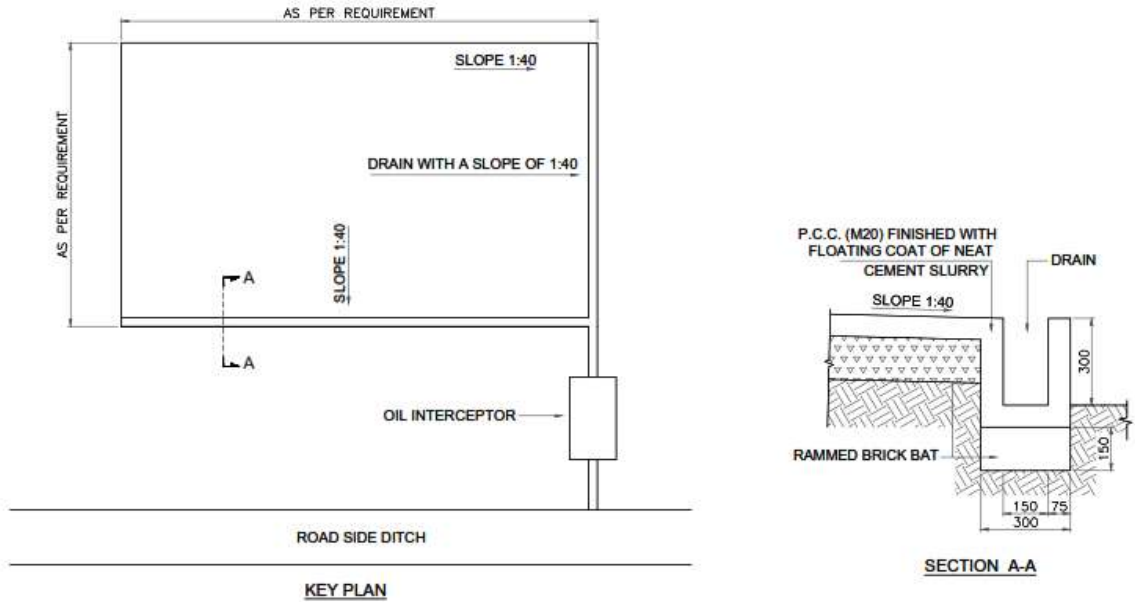

Figure. Oil Interceptor

APPENDIX 15: MANAGEMENT PLAN FOR LABOUR INFLUX

It is envisaged that during construction phase of the project, labourers for various road works will be hired through authorized manpower agencies by Contractor. As per ESIA for the project road, the migrant labour requirement will be around 90 for various road construction activities. Since, these will be employed from outside the region and will therefore, be migrant labourers and hence, accommodation will be provided. These migrant labourers will be accommodated in a temporary campsite within the project area. This could result in stress on local resources, disruption in community relations, and movement of labours.

Objective:

The influx of migrant labour will have both negative and positive impacts on the nearby community and local environment. The labour will be accommodated in temporary campsite within the project boundary which can have significant interface with the nearby community. However, the influx of migrant workers would lead to a transient increase of population in the immediate vicinity of the project area for a limited time. This would put pressure on the local resources such as roads, fuel wood, water etc.

Hence, a plan has been designed to addresses specific activities that will be undertaken to minimize the impact on the local community, including elements such as worker codes of conduct, training programs on HIV/AIDS, etc

The Plan demonstrate the;

- Potential impacts associated with influx on the host population and receiving environment are minimized;
- Provision of safe and healthy working conditions, and a comfortable environment for migrant labour; and
- compliance with the ESS-2 (Labour and Working Conditions), ESS-4 (Community Health and Safety) of the WB ESMF and other national labour laws;

As per ESS-2, Labour and Working Conditions; it focuses on the protection of the basic rights of workers, fostering constructive worker-management relationships, as well as promoting fair treatment and the provision of a safe and healthy workplace.

As per ESS-4, Community Health and Safety; it focuses on minimization and management of health and safety risks to local communities; and to ensure that the project does not harm community health and safety

A Labour Influx Management Plan addresses specific activities that will be undertaken to minimize the impact on the local community, including elements such as worker codes of conduct, training programs on HIV/AIDS, etc

Potential Impacts due to labour influx:

Labour influx for construction works can lead to a variety of adverse social and environmental risks and impacts.

The environmental impacts listed below are more likely to be of relevant for project;

- **Inadequate waste disposal and illegal waste disposal sites;**

The project is located in rural environment and does not have sufficient local waste management capacities, which would likely lead to improper disposal practices.

- **Wastewater discharges;**

Project-related activities, along with worker's camps, and a lack of appropriate wastewater discharges may pollute nearby water resources.

- **Increased demand on freshwater resources;**

The provision of clean drinking water and water for hygiene purposes can result in increased pressure on freshwater resources in the project or camp site area.

- **Increased use of / demand for natural resources;**

This can include logging for construction, fuel wood collection, use of water resources, potential introduction of invasive or non-native species, and land degradation.

Adverse Social Impacts;

- **Risk of social conflict**

Conflicts may arise between the local community and the construction workers, which may be related to religious, cultural or ethnic differences, or based on competition for local resources.

- **Increased risk of illicit behavior and crime**

The influx of workers and service providers into communities may increase the rate of crimes and/or a perception of insecurity by the local community.

- **Increased risk of communicable diseases and burden on local health services**

The influx of people may bring communicable diseases to the project area, including sexually transmitted diseases (STDs), or the incoming workers may be exposed to diseases to which they have low resistance. This can result in an additional burden on local health resources. Workers with health concerns relating to substance abuse, mental issues or STDs may visit to local medical providers, thereby placing further stress on local resources.

- **Gender-based violence**

Construction workers are predominantly younger males. Those who are away from home on the construction job are typically separated from their family and act outside their normal sphere of social control. This can lead to inappropriate and criminal behaviour, such as sexual harassment of women and girls, exploitative sexual relations, and illicit sexual relations with minors from the local community.

- **Increase in traffic and related accidents**

Delivery of supplies for construction workers and the transportation of workers can lead to an increase in traffic, rise in accidents, as well as additional burden on the transportation infrastructure.

Minimize Labour Influx

To minimize labour influx contractor need to identify a suitable labour pool locally, hence it will not require to bring in large numbers of labourers, which will not only limit negative impacts, but also reduce the contractor's costs as they will not need to provide as large a labour camp.

Management/Mitigations Measures;

All migrant workers are envisaged to be accommodated in temporary campsite within the project area. If migrant workers are accompanied by their families, provisions should be made accordingly. Contractor

shall ensure implementation of the following measures to minimise the potential negative impacts of worker accommodation and workers on local communities:

Cleanliness: Pest extermination, vector control and disinfection are to be carried out throughout the living facilities in compliance with local requirements and/or good practice.

Complaints and incident reporting: A formal Complaints Procedure will be implemented to ensure timely and transparent response to complaints as received from labour.

Labour education: The workforce will be sensitized to local social and cultural practices through provision of an induction course for all employees that stipulates expected behavior;

Labour behaviour in campsite provided: A Code of behavior governing appropriate behavior in the accommodation facilities to be kept in place and to be strictly enforced. The contractor shall ensure implementation of the “rules of engagement” between labours living in campsite and community and shall be implemented by construction contractors for all engaged labours. Labour Compensation and Accommodation: Client shall ensure that labours are provided with benefits such as annual leave, weekly rest day, etc.

Accommodation to be provided for the construction labour which cover facilities (including catering facilities, dining areas, washing and laundry facilities etc.) and supporting utilities.

Worker’s Accommodation:

The PMC will supervise and monitor the activities performed by their contractor and accommodation facilities provided in the campsite. The following measures shall be provided:

- The labour will be provided with accommodation made of insulated material and locally available building material, etc.;
- The migrant workers with families shall be provided with individual accommodation comprising bedroom, sanitary and cooking facilities;
- The units will be supported by common latrines and bathing facilities duly segregated for male and female labour;
- Adequate number of toilets shall be provided in the accommodation facilities. A minimum of 1 unit to 15 males and 1 unit for 10 females shall be provided;
- The contractor shall provide a kitchen facility for the construction workers and the food will be of appropriate nutritional value and will consider religious/cultural backgrounds;
- All doors and windows shall be lockable and mobile partitions/curtains shall be provided for privacy;
- Facilities for the storage of personal belongings for workers shall be provided within the campsite only;
- Dustbins shall be provided for collection of garbage and will be removed on a daily basis;
- It is also required to provide first aid box in adequate numbers; and
- Ventilation should be appropriate for the climatic conditions and provide workers with a comfortable and healthy environment to rest and spend their spare time.

Security:

The contractor shall put in place the following security measures to ensure the safety of the workers. The following measures shall be incorporated:

- Access to the campsite shall be limited to the residing workforce;
- The contractor shall be responsible for deploying adequate number of guards;
- Adequate, day-time night-time lighting shall be provided;

- The security personnel shall be provided with training to respect the community traditions and in dealing with, use of force etc.; and
- The rental accommodation shall be provided with firefighting equipment and portable fire extinguishers.

Provision of Drinking Water

Access to an adequate and convenient supply of free potable water is necessity for workers. The domestic water supply shall be made available by the contractor.

- Safe drinking water conforming to the IS 10500:2012 for drinking water shall be provided;
- Private tanks can be utilized for provision of drinking water for the migrant labours;
- The direct usage of water from bore well should not be allowed and water shall be adequately treated;
- The Contractor should regularly monitor the quality of drinking water available; and
- All tanks used for the storage of drinking water are constructed and covered as to prevent water stored therein from becoming polluted or contaminated.

Cooking Arrangement:

The construction phase will involve engagement of large number of migrant people in the project area for a limited time. Hence, there shall be requirement of provision of cooking facilities (kitchen) as listed below:

- Places for food preparation are designed to permit good hygiene practices, including protection against contamination between and during food preparation;
- Adequate personal hygiene including designated areas for cleaning hands and cleaning of utensils; and
- All kitchen floors, ceiling and wall surfaces adjacent to or above food preparation and cooking areas are built using durable, non-absorbent, easily cleanable, non-toxic materials;
- Food preparation area to be durable, easily cleanable, non-corrosive surface made of non-toxic materials.

To ensure that the fuel need of labourers in the project area does not interfere with the local requirements, necessary arrangements for supply of cooking fuel to the labourers shall be done by the contractor. In case, fuel requirement for cooking purposes are only to be met by fuel wood then that must be purchased from authorized vendors.

Waste Water Generation:

There will of generation of wastewater from the campsite. About 80% of water used shall be generated as sewage/wastewater. Contractor shall ensure that the campsite are equipped with septic tank and soak pit for disposal of sewage or with mobile bio-toilets. It is also recommended that the storm water and sewage system should be separate. The surface water drainage shall include all necessary gutters, down pipes, gullies, traps, catch pits, manholes etc.

Sanitary and toilet facilities are constructed of materials that are easily cleanable. Sanitary and toilet facilities are required to be cleaned frequently and kept in working condition

Solid Waste Management:

The solid waste generated from campsite will mostly comprise of compostable wastes like vegetable residues (kitchen waste) and combustible waste like paper, cans, plastic and some non-degradable waste like glass/glass bottles.

Improper disposal of solid waste will lead to environmental degradation and health hazards to labour as well as nearby community.

The following measures shall be adopted by contractors for ensuring effective management of solid waste:

- The solid wastes of domestic nature generated shall be collected and stored separately in appropriate containers with proper sealing on them;
- Separate bins with proper markings in terms of recyclable or non- recyclable waste shall be provided in camp and kitchen premises in sufficient numbers for collection of garbage;
- Food waste and other refuse are to be adequately deposited in sealable containers and removed from the kitchen frequently to avoid accumulation. the local people in the vicinity can be contacted, if they needs it to feed domestic animals or for composting purposes.
- It is the responsibility of contractor to ensure safe disposal of all wastes generated out of labour camps.

Medical Facility:

Effective health management is necessary for preventing spread of communicable diseases among labour and within the adjoining community. The following medical facilities shall be provided by contractors for the construction workers:

- Adequate first aid kits shall be provided in the campsite in accessible place. The kit shall contain all type of medicines and dressing material;
- Contractor shall identify and train an adequate number of workers to provide first aid during medical emergencies;
- Regular health check-ups shall be carried out for the construction labourers every six month and health records shall be maintained.
- Information and awareness of communicable diseases, AIDS etc. shall be provided to workers.
- Basic collective social/rest spaces are provided to workers;

Inspection of camp sites:

Campsite shall be inspected at frequent intervals by Contractor's EHS officer to ensure that the facilities are well organized and maintained to acceptable and appropriate standards by the contractor. The key areas are:

- Daily sweeping of rooms and houses shall be undertaken;
- Regular cleaning of sanitary facilities shall be undertaken;
- The kitchen and canteen premises shall be established under good hygiene conditions;
- Daily meal times shall be fixed for the labour;
- Smoking and alcohol consumption shall be prohibited in the workplace;
- Water logging shall be prevented at areas near the accommodation facilities and adequate drainage is to be provided; and
- Checklists pertaining to the daily housekeeping schedule shall be maintained and displayed at houses, toilets and kitchen.

To limit the impact due to cumulative labour onsite during construction phase, contractor shall provide adequate number of labour camps, which should be appropriate for its location and be clean, safe and, at a minimum, meet the basic needs of workers.

- Contractor should assess the location of labour camp, that it should not be constructed in immediate vicinity of any drainage channel;
- All tanks used for the storage of drinking and cooking water to be covered as to prevent water stored therein from becoming polluted or contaminated and all the migrant workers will be

instructed accordingly;

- Contractor should ensure that accommodation which is provided is not overcrowded and does not pose a risk to the health and safety of workers;
- The labour camp will be equipped with septic tanks and soak pits and avoid presence of stagnant water is a factor of proliferation of potential disease vectors such as mosquitoes;
- Contractor should ensure that the disruption of local communities is minimum and if required limit the worker's movements in the nearby areas;
- Security staff should have a clear mandate and instructions about their duties and responsibilities such as not to harass, intimidate, discipline or discriminate against workers;
- Contractor should ensure that workers and members of the surrounding communities have specific means to raise concerns about security arrangement and staff;

Grievance Redress Mechanism:

A Grievance Redress Mechanism (GRM) shall be formulated for the construction labourers (local and migrant) comprising of a review committee including representatives elected by labour and management representatives. A documented GRM shall have the following elements:

- Proper system for lodging grievances;
- Provision for raising anonymous complaints;
- Appropriate level of management for addressing concerns;
- Workers have specific means to raise concerns about security arrangement and staff;
- Provision for timely action and feedback;
- Monitoring and review of grievances raised and action taken; and scope for continual improvement of the system.

APPENDIX 16: GOHP'S STRATEGY TO REHABILITATE AREAS INFESTED WITH INVASIVE ALIEN PLANT SPECIES (EXOTIC WEEDS) IN HIMACHAL PRADESH

Strategy to Rehabilitate Areas Infested with Invasive Alien Plant Species (Exotic Weeds) in Himachal Pradesh: A Concept Note

Introduction

Large scale invasion of the Himachal's landscape by alien plant species over the past 20 odd years has become a cause of serious concern from the ecological, biodiversity, socio-economic and health point of view. Even as the list of alien plant species having become invasive in the State is fairly long, it is the following four exotic weed species that need priority attention:

a. *Lantana camara* L. (Lantana, Fulnu-buti, Panch-phulli, Ujrhu): This Tropical American species belongs to family Verbenaceae and has been declared as Weed of National Significance by more than 60 countries across the globe. It has come to occupy almost all the forest and non-forest areas in the sub-tropical belt in the State badly affecting the native floral diversity and availability of grass.

b. *Parthenium hysterophorus* L. (Carrot Weed, Congress Grass, Gajar ghas, Chatak Chandni): A member of family Asteraceae and a native of Tropical America, this herb is an aggressive colonizer of degraded areas with poor ground cover and exposed soil such as agricultural fallows, wastelands, roadsides, soil dumps, overgrazed pastures and degraded forests. The species, in addition to its adverse ecological impacts, has become a serious health hazard, causing allergic reactions in human beings.

c. *Ageratum conyzoides* L. (Goat Weed, Neel-phulnu): This noxious herb, a member of family Asteraceae, is a native of Tropical America. It has come to occupy agricultural fields, wastelands, plantations, pastures and all forest types, posing a serious threat to the indigenous vegetation in the State.

d. *Eupatorium adenophorum* Sp. (Crofton Weed): A member of family Asteraceae, this shrub is a native of Mexico. It forms dense thickets in fallow and wastelands, degraded forests and forest fringes out-spacing the indigenous species. The plant also causes allergic reactions and is a potential health hazard.

The above invasive alien plant species, with major incidence in the subtropical and lower temperate areas in the State, have come to affect the quality of forests and the pasture lands. What is more worrying is that their incidence seems to be increasing every year at a quite fast 'Speed of Spread'. No wonder that the problem of alien weeds has been recognized as the priority management subject during this International Year of Forests, 2011. State's Grazing Advisory Committee has also been raising concerns about the spread of these weeds and their effect on the pasture lands and grass availability. The issue has also become a subject of regular discussion in the State Assembly.

Extent of Spread

A forest-wise reconnaissance, carried out during March 2011 across the State, has brought out that *Lantana* alone has invaded 1.5 lakh hectares of forest lands. Similarly, the other three main exotic weeds (*Parthenium*, *Ageratum*, *Eupatorium*) have been recorded to occur over 0.50 lakh hectares of forests, especially pastures.

In addition, these exotic weeds have also come to occupy most of the roadsides and the waste lands. The road length, passing through the sub-tropical/ lower temperate zone in the State being

approximately 20,000 kms with an average of 2.5 m berm on either side of these roads, the area under the exotic weeds along roadsides works out to an estimated 10,000 hectares. More than 80% of the exotic weed infestation along road sides is on account of *Parthenium*, *Ageratum* and *Eupatorium*.

Data about extent of spread of exotic noxious weeds on wastelands/ fallow lands is not available. However, assuming that the exotic weeds occupy most of the lands classified as barren/ unculturable; culturable wastes and fallow in the sub-tropical/ lower temperate zones (apprx. 1500 km²), the area under the exotic weeds on such lands works out to an estimated 1.5 lakh hectares. About 80% of this infestation is with *Parthenium*, *Ageratum* and *Eupatorium*.

An idea about the enormity of the problem at hand can be had from the consolidated figures presented in the table below:

Description of land	Estimated Infestation of Invasive Alien Species (Area in ha.)		Total (Area in ha.)
	Lantana	Others (<i>Parthenium</i> , <i>Ageratum</i> , <i>Eupatorium</i>)	
Forest land	1,50,000	50,000	2,00,000
Road sides	2,000	8,000	10,000
Lands classified as barren; cultivable wastes & fallow	25,000	1,25,000	1,50,000
Total (Area in ha.):	1,77,000	1,83,000	3,60,000

Analysis of the data presented in Table above reveals that whereas '*Lantana*' is the major noxious species of forest habitats under the administrative control of HP Forest Department, it is *Parthenium*, *Ageratum* and *Eupatorium* that form the major exotic weed species along road sides and on lands classified as barren, culturable wastes and fallow, major chunk of which is privately owned. Whereas the incidence of *Parthenium* is largely restricted to degraded and newly opened drier sites along roads and forest fringes, the other three invasive alien species tend to occupy all possible vacant places even under tree canopy. Even as *Eupatorium* and *Ageratum* show a clear preference for moister locales and show gregarious occurrence, at many places these share the niche and grow in an intimate mix with *Lantana*. It is, therefore, imperative that the management strategy should focus on comprehensive rehabilitation of areas infested with exotic weeds and not merely limit itself to any specific exotic weed species.

Another issue that has emerged from the recent survey is the '**Speed of Spread**' of invasive alien species, with more than 40% of the infestation reported as having taken place over the past decade only. There being little control over the various extraneous factors contributing to the spread of exotic weeds, viz. cutting of lands for roads and projects, muck dumping, uncontrolled grazing, innate biological traits of weeds, etc. the infestation is still continuing at an alarming rate. The fast changing life style, that include abandoning of marginal farm lands and voluntary keeping the surrounds clear of weeds, has only added to the pace of spread of these exotic weeds.

Past Efforts at Management of Invasive Alien Species in the State

By H P Forest Department: Some efforts at management of these weeds, especially in the forests sector in the State and revolving around mechanical/ cultural and chemical methods, have been made. Limited efforts at use of *Lantana* for making low cost furniture, coal brickets and compost have also been made in the past.

However, these management efforts, revolving mainly around mechanical removal of the exotic weeds, have been too few and too far spread to create any significant impact. An idea about the scale of intervention can be had from the fact that over the past three years, only about 1,700 hectare of forest area has been tackled under the weed management program.

Moreover, these efforts were largely taken up as one time interventions at weed removal and were not focused on rehabilitation of the treated area. Most of the past efforts have not yielded desired results due to lack of focus on long-term follow up system.

Chemical methods (involving mainly application of glyphosate) at control of *Lantana/ Parthenium* were abandoned after initial trials due to concerns about their adverse environmental implications. Associating *Lantana* removal to use has also not found favour with the local communities, the outputs/ returns from using cut *Lantana* for furniture, bricketting or composting being not considered commensurate with the effort required for its use.

By Other Organizations: The Himachal Pradesh Agriculture University has been working to develop successful models of managing exotic weeds. It has also been, around Palampur, spearheading *Parthenium* eradication campaigns in association with educational institutions and civil society organizations. However, these campaigns have been too limited to create large scale impact.

Major learning from the past efforts at eradication of invasive alien plant species is that such efforts need to be integrated with rehabilitation of treated areas and should be of long-term duration for effective results.

Strategy for Management of Invasive Alien Species on Forest Lands

A two-day workshop was organized by the Himachal Pradesh Forest Department at Sundernagar on 22-23 April 2011 with a view to come out with the following broad outputs –

- 1) documentation of species-wise/ forest-wise spread of major exotic weed species
- 2) documentation and review of the past efforts at weed management
- 3) emergence of a comprehensive strategy to rehabilitate the areas infested with the major weed species

The workshop was attended by the subject matter experts from within and outside Himachal Pradesh, forest managers, researchers, academicians, representatives of line departments and representatives of Civil Society Organisations. The workshop was inaugurated by Mr. Vinay Tandon, Pr. Chief Conservator of Forests, Himcahal Pradesh. Prof. R. K. Kohli, Chairman Botany Department, Punjab University and IUFRO Chair on Invasive Alien Species delivered the Key Note address. The highlight of the technical sessions was forest Circle-wise presentations by the Conservators of Forests, giving detailed status of exotic weeds on forest lands in their respective circles. The invited subject matter experts included Prof. N N Angiras (KV, Palampur), Prof. M K Seth (HPU, Shimla), Dr. S S Samant (G B Pant Institute, Mohal) and Dr. Kuldip Dogra (Research Fellow), who shared their experience related to the status and management strategies of exotic weeds. Mr. Santosh Kumar, Conservator of Forests, Chandigarh presented a case study about successful *Lantana* management interventions in Sukhna Wildlife Sanctuary. Dr. Anjan Kalia (representing CSO, Palampur) shared his perspective regarding the need to undertake eradication of *Parthenium* through ‘people’s movement’.

The two day deliberations on the issue resulted in the emergence of a draft strategy for management of exotic weeds in the State, highlights of which are presented below:

Core Principles of the Strategy are set out as below

- Contain Further Spread:

To set up biennial monitoring protocols to keep watch over the spread of exotic weeds and take immediate remedial measures to remove recent infestations, if any.

- Complete Rehabilitation of Infested Areas:

It will involve shift from the present methods of ‘one time removal of weeds’ to ‘complete rehabilitation’ of the treated areas. Under this approach all the four above mentioned noxious exotic weeds will be tackled simultaneously. For this a comprehensive system of long-term follow up action with appropriate budgetary support will be evolved.

- Reliance on only Mechanical/ Manual Methods:

In view of their environmental/ ecological concerns, the rehabilitation measures will NOT employ any Chemicals/ Biological methods of exotic weed control.

- Natural Resilience of Native Flora to be the basis of Rehabilitation Action:

The natural regeneration of indigenous plant species on treated sites will be encouraged and facilitated to establish towards better environmental and ecological services, including fodder, fuel, water recharge, etc.

- No Exotic Plant Species to be used to Rehabilitate Treated Sites.

*No potentially invasive exotic species – (viz. *Leucaena leucocephala*, *Prosopis juliflora*, Teak, Darek, Silver Oak, *Jatropha curcus*, *Tecoma stans*, etc.) – will be used for plantations in the areas under weed management, because of their deleterious effect on the native flora.*

- Rehabilitation to start from Low Intensity Infestation Areas and to progress towards areas with Heavy Infestation:

Rehabilitation activities will start from the fringes of infestation zone with lower intensity infestation and will progress towards the heavily infestation areas. This approach will (i) allow tackling larger areas with the given financial resources and result in creating quick visible impact, and (ii) help in containing further spread of exotic weeds.

- Priority Rehabilitation of Heavily Infested Critical Habitats:

*Rehabilitation of heavily infested areas as starting point will be taken up only in limited number of carefully selected **critical habitats** like grazing grounds near habitations. Such sites will then act as nucleus from where rehabilitation activity will radiate to adjoining areas of high infestation.*

- Multi-Stakeholder Participation:

Since all landscape elements in the State are already infested with noxious exotic weeds, the departments/ agencies dealing with different land use elements would need to join hands to effectively tackle this menace.

- Working under Campaign Mode:

The problem being enormous, it would need building larger societal consensus and engaging civil society organizations and local people/ social groups to effectively tackle this problem. It is possible under a campaign mode for which viable implementation mechanism would be evolved.

Methods for Strategy Implementation

- Forest Beat will be the Unit for Rehabilitating Exotic Weed Infested Areas:

It will create comprehensive visible impact and show quick results of rehabilitation action.

- *Forest beats with lowest infestation will be selected first.*
- *Within the selected beat, rehabilitation action will start from the areas with least infestation.*
- *Heavily infested critical habitat in the selected beat, if any needed to be tackled on priority basis, will be selected/ approved by the concerned DFO.*
- *Financial resources available for the purpose under various schemes will be converged to rehabilitate all areas under the selected beat in the shortest possible time.*

- All Noxious Exotic Weed Species will be Tackled Simultaneously:
All the noxious exotic weeds will be tackled simultaneously on the selected area to ensure complete rehabilitation of the infested areas.
- Method of Removing Exotic Weeds will be as under:
The invasive plant species will be removed by employing only mechanical/ manual methods, as given below:
 - *Lantana will be cut by using Cut Root Stock (CRS) method i.e. cutting the bushes below the soil to prevent coppicing (Annexure-II).*
 - *Other exotic weeds will be uprooted/ cut along the ground.*
- The following will be standardized for effective implementation of exotic weed management initiative:
 - *Cutting tools/ techniques*
 - *Calendar of rehabilitation activities*
 - *Cost models*
- A three year intensive maintenance of the treated areas and periodic follow up (every 3 years?) thereafter will form integral part of the rehabilitation program till the areas gets fully rehabilitated.
- Local people, through existing community groups, will be actively engaged to participate in rehabilitation of exotic weed infested areas.

Funding Options

The State Forest Department will explore funding possibilities for this initiative under State CAMPA/ NPV funds; Centrally Sponsored Schemes ('Control & Eradication of Forest Invasive Species' under Intensification of Forest Management Program); Regular Departmental Plantation Schemes; and MNREGA.

State CAMPA/ NPV: An initial allocation for rehabilitation of 1000 hectares per year under State CAMPA/ NPV funds has already been made.

CAT Plans: Rehabilitation of areas infested with invasive alien plant species also forms integral part of some of the CAT Plans (e.g. UHL Stage-III). There is a need to work out the total areas to be tackled for the purpose under various CAT Plans in the State to know the total extent of areas being tackled under this budget head.

MNREGA: This scheme offers a great potential for management of exotic weed infested areas. However, there are certain issues that need to be sorted out for achieving effective results. The major issues being (a) inclusion of exotic weed removal as integral part of the Panchayat's annual development agenda, (b) making available able bodied registered beneficiaries at right time of the year to handle this strenuous work, often away from the habitations (c) incorporation of nursery raising as one of the approved activities under the scheme, (d) provision for at least three year maintenance of the treated areas.

Management of Invasive Alien Species on Non-Forest Lands

As already brought out, a large chunk of non-forest land mass in the State is also facing increasing invasion of alien plant species. The situation is especially severe along road sides and waste lands/ fallow lands where heavy infestation by noxious exotic weeds has not only resulted in reduction in the traditional grazing grounds but has also become a cause of serious health hazard.

The State Rural Development Department, Agriculture Department, Horticulture Department, Public Works Department and the Municipal bodies will initiate appropriate measures for management of noxious weeds on non-forest areas based on the broad strategy principles as brought out above.

It is expected that the above strategy will effectively guide the program to manage invasive alien plant species in the State in a time bound manner.

Forest Circle-wise incidence of exotic weeds on forest lands, as recorded during January-March 2011, is given in below table.

Circle-Wise Incidence of Exotic Weed Infestation in Forest Areas
(Based on field data collected by field offices during January-March 2011)

Circle	Forest Area under the Invasion of				
	<i>Lantana</i>	<i>Ageratum</i>	<i>Parthenium</i>	<i>Eupatorium</i>	Total
Nahan	21,456.99	4,302.51	4,260.73	595.87	30,616.10
Bilaspur	55,941.55	0	0	0	55,941.55
Mandi	7,900.00	2,360.00			10,260.00
Hamirpur	12,680.00	0	0	0	12,680.00
Dharamshala	47,403.00	12,810.00			60,213.00
Shimla	4,060.89	0	1,100.00	0	5,160.89
Rampur	0	0	0	0	0
Chamba	4,631.77	132.91	68.5	85.4	4,918.58
Kullu	575.7	0	284.3	137.25	997.25
WL (S)	475.06	683.98	611.44	190.5	1,960.98
WL (N)	1,160.00	54	0	1,239.00	2,453.00
WL (GHNP)	0	0	0	0	0
Total	1,56,284.96	20,343.40	6,324.97	2,248.02	1,85,201.35

Note:

1. As the data was collected during winter months when species like *Eupatorium* & *Parthenium* are still in dormancy, their incidence seems to be under-reported.
2. More than one species of exotic weeds seem to occur either in an intimate mixture or in distinct gregarious patches in the same forest.
3. Thus, any strategy for their management needs to be focus on rehabilitation of areas by simultaneously removing all exotic weed species and should not be species specific.

Compiled by:

CCF (Fl. Div., NTFP & Res. Mgmt.)

Sundernagar

Method for Removal of *Lantana*

Removal of adult clumps using ‘Cut Root Stock’ (CRS) method: This method involves cutting the main tap root of *Lantana* plant beneath the ‘coppicing zone’ (transition zone between stem base and rootstock). This method of removal involves engagement of 2–3 individuals to work in a group for the removal of *Lantana* if the clumps are too large to be handled by one individual after the rootstock is cut. The steps involved in the cut rootstock method are:

- (i) The person, who engages in removal of *Lantana*, is positioned in a way that he stands near centre of the *Lantana* clump with his back facing the clump and holding the handle of digger (kudal).
- (ii) Using the specially designed digger, the person cuts the main rootstock of *Lantana* 3–5 cm below the soil surface by hitting the rootstock 3 or 4 times; while hitting the rootstock the blade of the digger gets lodged into the main tap root, and at this point it is useful to move the handle of the digger in the forward direction away from the body of the person so as to sever the connection of the clump with the main tap root. In case the clumps of *Lantana* form impenetrable thickets, it is advantageous to cut the rootstocks of 3–4 contiguous clumps to make the removal operation convenient. It may be noted that the branches of *Lantana* clumps should not be slashed/cut to gain access to the centre of the clump for its removal by cut rootstock method. The branches of *Lantana* thicket formed by more than one clump should be lifted and tipped over from one end by using a wooden or bamboo pole of about 1.5–2.5 m long and diameter 5–6 cm which is inserted just below the branches from one side and rolled over easily by two workers holding the pole at either end and pressing it so as to reach the centre of the clump.

Such manual handling of impenetrable thicket makes it possible to reach the centre of clump easily, as otherwise its umbrella type canopy makes it difficult to reach the main stem. Such physical manoeuvre also minimizes or prevents regeneration from rooted cut branches when they fall on the ground.

- (i) Lift the clump/(s) and place the clump/(s) upside down. If the clump is not placed upside down, the prostrate rooted branches and the aerial old branches having aerial roots at nodes may develop into adult plants when they come in contact with the soil. Therefore, the upside-down orientation of cut clumps is critical in the prevention of regeneration of *Lantana* from cut clumps. It may be noted that *Lantana* does not produce root suckers.
- (ii) After drying the clumps, the clumps may be used as fuel or burnt at the same site or all the dried clumps may be collected at one place and then burnt. The best time for removal of *Lantana* is just before rainy season, i.e. when the plants are not in flowering and fruiting.

APPENDIX 17: Disaster Management & Emergency Response Plan at Project Road Level

1. Disaster Management Plan¹ of Bilaspur District

Disaster Management has undergone a paradigm shift in recent years from the earlier approach of response to disasters to the current holistic approach of disaster mitigation and preparedness, which yields long term benefits while minimizing damage due to disasters. District Disaster Management Authority working under the aegis of Office of the Deputy Commissioner, Bilaspur is primarily responsible for disaster management in District Bilaspur. The District Authority is responsible for planning, coordination and implementation of disaster management and to take such measures for disaster management as provided in the guidelines.

The District Disaster Management Plan (DDMP) for Bilaspur district has been prepared for implementation by the Government and other non-Government agencies who would be involved in execution of the Plan during any disaster in the district. The plan indicates emergency action plans, roles and responsibilities of key personnel and suggests mitigation measures during any natural or manmade disaster, taking into consideration the available resources with various agencies involved. The plan evolves systems to make the plan an effective response mechanism. In short, the plan brings under one roof, various agencies and departments to control any type of disaster.

2. Aims & Objectives of District Disaster Management Plan

The overall aim of District Disaster Management Plan is to facilitate the actions by different stakeholders to prevent/mitigate disaster and climate risk and enhance preparedness and develop capacities for effective disaster management in the district. It further seeks to identify and clarify the roles and responsibilities of the internal and external stakeholders throughout the entire cycle of disaster management, i.e., pre-disaster, during disaster and post disaster phases.

The specific objectives of the DDMP are:

- to identify and map disaster risk,
- to strengthen the institutional arrangements in the district by identifying roles and responsibilities of the different stakeholders,
- to facilitate the enhanced level of preparedness of the different stakeholders and develop their capacities, preparation and implementation of action plan for disaster risk mitigation, strengthen mechanism for early warning, response & relief, guide rehabilitation & recovery and facilitate mechanism for monitoring, evaluation, revision and updation.
- to clarify the Authority, Responsibility and Relationships as to who is responsible for ensuring that the work gets done, distributing and decision-making authority among the team members and the existing organizational units, and establishing formal lines of communication.
- to facilitate the mobilization of resources, funds, personnel, supplies and equipment necessary for doing the required activities.
- to establish the communication and information management system
- to facilitate the Monitoring, Evaluation and updation of the plan from time to time.

The District Disaster Management Plan (DDMP) is a guide for achieving the objective related to disaster mitigation, preparedness, response and recovery. This Plan will help in disaster response in a planned way to minimize human, property and environmental loss.

The basic objectives for formulating a Plan are as under:

The basic objective of the District Disaster Management Plan is to protect all the residents of the district and all property from all sorts of untoward incidents through the following objectives:

¹ Information abstracted from District Disaster Management Plan, Bilaspur

- **Clarifying Authority, Responsibility and Relationships:-** Clarifying as to who is responsible for ensuring that the work gets done, distributing and decision making authority among the team members and the existing organizational units, and establishing formal lines of communication.
- **Obtaining Resources:** - Obtaining funds, personnel, supplies and equipment necessary for doing the required activities.
- **Establishing the Control System:** - Determining the nature of information, which is necessary for carrying out activities, identifying sources of such information and setting up reporting systems for Disaster Management
- **Monitoring, Evaluation and Updation:** - The plan needs to be monitored from time to time and updated.

3. Authority for the DDMP: DM Act 2005

On 23rd December 2005, the Government of India took a defining step by enacting the Disaster Management Act, 2005, which envisaged creation of Authorities at all three levels as below:

- The National Disaster Management Authority (NDMA) headed by the Prime Minister.
- The State Disaster Management Authorities (SDMA) headed by the Chief Ministers.
- The District Disaster Management Authorities (DDMA) headed by the District Magistrates or Deputy Commissioners as the case may be.

The DDMA under the Chairmanship of Deputy Commissioner has been notified by the government in the year 2007. The district level planning team having DEOC coordinator and Head of departments like Police, PWD, HPSEBL, IPH, Forest, Health, food and civil supplies, civil defense, Panchayati Raj, telecom, Public relations, Education, agriculture and horticulture as members has been constituted under the chairmanship of Deputy Commissioner. Four subdivision level planning committees under the control of SDMs has also been framed.

4. Evolution of the Plan

Preparation of the District Disaster Management Plan is the responsibility of the District Disaster Management Authority of the Bilaspur. While preparing a District Disaster Management Plan for Bilaspur district, the data collected from the Line departments. After compilation of data, yearly meeting for DDMP update will be organized by the DDMA under the chairmanship of the Deputy Commissioner, Bilaspur. The Deputy Commissioner will ensure for the progress and gap analysis. All concerned departments and agencies must participate and give recommendations on specific issues and submit their updated reports on the above-mentioned factors to the District Revenue Officer cum Nodal officer DDMA Bilaspur. The District Revenue Officer-Bilaspur assist by District Training & capacity Building Coordinator to update the DDMP & coordination with District Information Officer Bilaspur to upload the DDMP of the district web site every year.

The main steps involved in the development of this plan are:

- Data analysis
- Discussion with experts
- Reference of national and international literature
- Mock exercise to check the viability and feasibility of the implementation methodology
- Wide circulation for public and departmental comments

5. Stakeholders & Responsibilities

At the District level, District Disaster Management Authority, with the Deputy Commissioner / District Collector designated as Response Officer (RO), and other line departments at district HQ are responsible to

deal with all phases of disaster management within district. The role of the stakeholders has been prepared with the sole objective of making the concerned organizations understand their duties and responsibilities regarding disaster management at all levels and accomplishing them.

Role & Responsibility of Various Stakeholders at district level

Sl. No.	Stakeholders	Responsibilities
1	NDMA	<ul style="list-style-type: none"> ● To provide guidance and support for implementation of policies and plans related to disaster management. ● To deploy NDRF on request by SDMA&DDMA ● To coordinate and monitor with the state for the implementation of the policies and plans related to Disaster management. ● To facilitate mobilization and deployment of specialized resources on request by the DDMA /HPSDMA.
2	HPSDMA	<ul style="list-style-type: none"> ● To approve the DDMP. ● To provide guidance and direction for preparation, revision, updation and implementation of the DDMP. ● To issue and provide disaster management guidelines. ● To support mitigation, response, rehabilitation, and capacity building actions. ● Monitor and evaluate implementation of the DDMP. ● To coordinate with NDMA, MHA and other stakeholders for implementation of the DDMP. ● Coordinating DRR activities and implementation thereof. ● Facilitating resources on demands rise by administration.
3	DDMA	<ul style="list-style-type: none"> ● To Updation and implementation of DDMP. ● To Conducting meetings on disaster management. ● Building capacity by trainings and awareness ● To managing all resources at district level ● To coordinating with stakeholders and liaisoning ● To enable local authorities to establish contact with the state authorities and other departments ● To coordinate planning procedures between district, the state and the center. ● To provide ready formats for all formal reporting procedures as a standby. ● To operate a Disaster Welfare Information (DWI) System to collect, receive, and report and status of victims and assist family reunification. ● To coordinate planning procedures between district, the state and the center. ● To provide ready formats for all reporting procedures as a standby
4	DEOC	<ul style="list-style-type: none"> ● To receive and process disaster alerts and warnings from nodal agencies and other sources and communicate the same to all designated authorities. ● To monitor emergency operations. ● To facilitate coordination among primary and secondary ESFs/Departments/Agencies ● To requisitioning additional resources during the disaster phase. ● To issuing disaster/incident specific information and instructions specific to all

Sl. No.	Stakeholders	Responsibilities
		<p>concerned.</p> <ul style="list-style-type: none"> ● To consolidation, analysis, and dissemination of damage, loss and needs assessment data. ● To forwarding of consolidated reports to all designated authorities.
5	Police Department	<ul style="list-style-type: none"> ● Having sound communication and security plan in place to coordinate law and order issues. ● To ensure action as per assigned responsibilities under emergency support functions assigned as per this plan ● Training to security personnel in handling disaster situations and issues related to them.
6	Revenue	<ul style="list-style-type: none"> ● To ensure action as per assigned responsibilities under emergency support functions ● Training of Patwaris and Field Kanungos with reference to disaster. ● To collect damage report from the ground through PRI's and patwaris.
7	Civil Defense, Home Guards, and Emergency Services	<ul style="list-style-type: none"> ● To support the primary agencies in responding during the incident ● To enhance the level of departmental preparedness for emergency response ● To ensure action as per assigned responsibilities under emergency support functions assigned as per this plan ● To coordinate search and rescue logistics during field operations. ● To provide status reports of S&R updates throughout the affected areas.
8	Department of Health and Family Welfare	<ul style="list-style-type: none"> ● To implement action plan for disaster risk mitigation in hospitals and other health infrastructures ● To enhance the level of departmental preparedness for emergency response ● To ensure action as per assigned responsibilities under emergency support functions assigned as per this plan ● To coordinate, direct and integrate State level response and activation of medical personnel, supplies and equipment ● To Provide human services under the Department of health ● To prepare, keep and check ready Mobile Hospitals, stocks of equipment and drugs ● To coordinate with private health service providers ● To provide resources for mass level water decontamination ● Special care for women with infants and pregnant women
9	Regional Transport	<ul style="list-style-type: none"> ● Overall coordination of the requirement of transport in implementing emergency related response and recovery functions, search and rescue and damage assessment. ● To make an inventory of vehicles available for various purposes.
10	HP PWD	<ul style="list-style-type: none"> ● To implement departmental action plan for disaster risk mitigation ● To enhance the level of departmental preparedness for emergency response ● To ensure action as per assigned responsibilities under emergency support functions assigned as per this plan ● Emergency clearing of debris to enable reconnaissance, Clearing of roads, ● To assemble casual labour, provide a work team carrying emergency tool kits,

Sl. No.	Stakeholders	Responsibilities
		<p>depending on the nature of disaster, essential equipment such as Towing vehicles, Earth moving equipment Cranes etc.</p> <ul style="list-style-type: none"> ● To construct temporary roads; Keep national and other main highways clear from disaster effects such as debris etc. ● To coordination with private services providers for supply of earth moving equipment etc.
11	BSNL (Communication other service provider)	<ul style="list-style-type: none"> ● To enhance the level of departmental preparedness for emergency response. ● Coordination of national actions to assure the provision of telecommunication support to the state and district. ● Coordinate the requirement of temporary telecommunication in the affected areas. ● To ensure action as per assigned responsibilities under emergency support functions assigned as per this plan
12	Department of Food and Public Distribution	<ul style="list-style-type: none"> ● To enhance the level of departmental preparedness for emergency response ● To identify requirement of food and clothing for affected population. ● To control the quality and quantity of food, clothing and basic medicines. ● To ensure the timely distribution of food and clothing to the people. ● To ensure that all food that is distributed is fit for human consumption.
13	Department of Irrigation & Public Health	<ul style="list-style-type: none"> ● To implement departmental action plan for disaster risk mitigation ● Procurement of clean drinking water. ● Transportation of water with minimum wastage. ● To ensure special care to the vulnerable communities ● To ensure that sewer pipes and drainage are kept separate from drinking water facilities.
14	Department of Public Relations	<ul style="list-style-type: none"> ● To provide and collect reliable information on the status of the disaster and disaster victims for effective coordination. ● To coordinate with all TV and radio networks to send news flashes for specific do's, don'ts & needs. ● To respect the socio-cultural and emotional state of the disaster victims while collecting information for dissemination. ● To enhance the level of departmental preparedness for emergency response ● To ensure action as per assigned responsibilities under emergency support functions assigned as per this plan.
15	Department of Animal Husbandry	<ul style="list-style-type: none"> ● To implement departmental action plan for disaster risk mitigation ● To enhance the level of departmental preparedness for emergency response ● To ensure action as per assigned responsibilities under emergency support functions assigned as per this plan ● Treatment of animals (Domestic and Wild) ● Provision of vaccination ● Disposal of dead animals
16	HPSEB Ltd.	<ul style="list-style-type: none"> ● To enhance the level of departmental preparedness for emergency response ● To ensure action as per assigned responsibilities under emergency support functions assigned as per this plan

Sl. No.	Stakeholders	Responsibilities
		<ul style="list-style-type: none"> ● To provide and coordinate with State and support until the local authorities are prepared to handle all power related problems. ● To identify requirements of external equipment required such as DG sets, generators etc. ● Damage Assessment.
17	Forest department	<ul style="list-style-type: none"> ● To implement departmental action plan for disaster risk mitigation ● To enhance the level of departmental preparedness for emergency response ● To ensure action as per assigned responsibilities under emergency support functions assigned as per this plan ● To prevent, mitigate risk of forest fires and provide emergency support functions ● To keep the department prepared for supporting the DDMP ● To removal of fallen trees and Forestation or shifting of trees. ● To provide fuel wood for the relief camps and public. ● Have adequate storage of fuel wood and make arrangement for distribution thereof;
18	ULB/PRI	<ul style="list-style-type: none"> ● To prepare and implement DM Plan for Municipal council/Panchayat ● To enhance the level of municipal preparedness for emergency response ● Land Usage Planning. ● To ensure action as per assigned responsibilities under emergency support functions assigned as per this plan ● Solid/ liquid waste treatment and management. ● To ensure action as per assigned responsibilities under emergency support functions assigned as per this plan ● Arrange adequate material and manpower to maintain cleanliness and hygiene.
19	Transport	<ul style="list-style-type: none"> ● To implement departmental action plan for disaster risk mitigation ● To enhance the level of departmental preparedness for emergency response ● To ensure action as per assigned responsibilities under emergency support functions assigned as per this plan ● Overall coordination of the requirement of transport in implement emergency related response and recovery functions, search and rescue and damage assessment. ● To make an inventory of vehicles available for various purposes;
20	DRDA	<ul style="list-style-type: none"> ● To enhance the level of departmental preparedness for emergency response ● Awareness regarding DRR at Panchayat Level. ● To make arrangement for proposal disposal of waste in their respective areas. ● To arrange adequate material and manpower to maintain cleanliness and hygiene. ● To implement departmental action plan for disaster risk mitigation ● To ensure action as per assigned responsibilities under emergency support functions assigned as per this plan ● To make arrangement for proposal disposal of waste in their respective areas ● To arrange adequate material and manpower to maintain cleanliness and hygiene.

Sl. No.	Stakeholders	Responsibilities
21	NDRF, Nurpur Armed Transit Camp at Pandoh	<ul style="list-style-type: none"> • To ensure action as per assigned responsibilities under emergency support functions. • Carrying out search and rescue on requisition by District as well as state administration. • Strengthening the response mechanism through trainings and awareness. • To coordinate with administration in response as well as capacity building. • To facilitate administration with the key resources in disaster.

6. Hazard Profile of Bilaspur District

Bilaspur District is prone to severe Earthquake and other Natural Hazards like Floods, Hailstorm, Fire, Lightening and Manmade Disaster like Road Accident, etc. Bilaspur District has been traditionally vulnerable to hazards due to its geographical position they always contribute to a certain scale of damage, both in quantitative as well as qualitative terms. In simple words, a hazard is probability of occurrence of an event that has the potential for causing injury to life or damage to property or the environment. District is prone to the following five types of hazards:

Types of Hazards	
Geologically	<ul style="list-style-type: none"> • Earthquake • Land slide and fluid flow • Dam failure
Water and climate	<ul style="list-style-type: none"> • Floods • Hailstorm • Heat wave and cold wave • Droughts • Thunder and lightning • Cloud burst
Chemical industrial and nuclear hazards	<ul style="list-style-type: none"> • Chemical and industrial disaster • Nuclear disaster
Accident-related hazards	<ul style="list-style-type: none"> • Forest Fire • Urban Fire • Major Building Collapse • Serial Bomb Blast • Festival related disasters • Electrical Disasters and Fires • Air, Road accidents • Boat Capsizing • Village Fire
Biologically Related hazards	<ul style="list-style-type: none"> • Pest Attacks • Cattle Epidemics • Food Poisoning

Hazard Profile of Bilaspur District (Sub-division wise)

Sr. No.	Hazard Type	Name of Sub-Division & Hazard Vulnerability			
		Sadar*	Ghumarwin	Jhandutta	Shri Naina Devi JI
1	Earthquake	Moderate	High	Moderate	Moderate
2	Flesh Flood	Low	Low	Moderate	Low
3	Landslide	Moderate	Low	Moderate	Moderate
4	Forest Fire	Low	Moderate	High	High
5	Domestic Fire	Moderate	Moderate	Moderate	Moderate
6	Drought	Moderate	Moderate	Moderate	Moderate
7	Road Accidents	Moderate	Moderate	Moderate	High
8	Boat Accidents	Low	Low	Low	Low

* Relevant to Raghunathpura Bharari Road under HPSRTP

To help the local administration to work towards risk reduction and disaster resiliency, the first step is to prepare a hazard assessment for the district. Therefore, this section provides a detailed explanation of the hazards that, historically, have been hitting Bilaspur, as well as hazards to which the district is prone to due to geo-climatic characteristics.

The hazards faced by the district of Bilaspur are listed below. It is worth emphasizing that the main potential impacts associated with these hazards are high and can assume devastating proportions, both on social

7. Seasonal Mapping & Risk Matrix of Bilaspur District

The seasonal mapping & risk matrix of national hazards of Bilaspur district is given in table below. Floods are most likely to happen between June and sept, whereas Forest Fire in the months of April / May and September to November. Hazards, as earthquake, may occur at any time. It is important that the local administration plan accordingly - measures to mitigate the risks related to these hazards have to be taken in advance and the community trained well-before the probable period of each hazard.

Probability of Seasonal Hazards of Bilaspur District

Hazard	Probable Months											
	Jan	Feb	Mar	April	May	June	July	August	Sept	Oct	Nov	Dec
Flood												
Forest Fire												
Drought												
Earthquake												
Cold Event												
Heat wave												
Hailstorm												
High Winds												
Road accident												

Risk matrix of the Bilaspur District

Hazard	Probability	Impact	Risk
Earthquake	Medium	High	High
Flood	Low	Low	Low
Forest Fire	High	High	High
Drought	Low	Medium	Medium
Landslide	Medium	Low	Low
Road Accidents	Medium	Low	Low
Boat Accidents	Low	Low	Low
Stampede	Medium	Low	Low

8. Government Workforce for Disaster Management

Every department had nominated their Nodal Officer for the Disaster Management and the inventory is updated under the guidance of Nodal Officer. This workforce can act as a resource for disaster management in the district. However, this resource has yet not fully trained and oriented in DM and related issues. Hence their capacity to respond to disasters effectively and prepare a culture of prevention and safety would be less effective.

9. Fire Services and Home Guards

The Home Guards and Fire Services will be assigned an effective role in the field of disaster management. They will be deployed for community preparedness, conduct of mock drill and public awareness. A culture of voluntary reporting to duty stations in the event of any disaster will be promoted. The Fire Services upgraded to acquire multi-hazard rescue capability. The existing set up of these services would be strengthened to take up the new role more effectively.

10. Fire Stations & Fire Fighting Facilities

Bilaspur district has 2 fire stations, to deal with the fire incidents.

11. Home Guard Network

In case of major incidents Home Guards can be pressed to service. In any emergent situation Home Guards are readily available for deployment.

12. Police Stations

Number of Police stations & Police Chowki including details of their staff, list of equipment's available, details of infrastructure including age or building (when was building made), details of medical facility available, details of food & water supply facility, about how many male & female toilets are there to cope up at the time of any disastrous condition. GIS mapping also in progress to map the available resources in the Bilaspur district.

List of Police Stations of Bilaspur District

Sl. No.	Name of Police Station	Contact Number
1.	Barmana	94180-71662, 01978-244040
2.	Bharari	94188-08080, 01978-273026
3.	Ghumarwin	94183-38156, 01978-255216

Sl. No.	Name of Police Station	Contact Number
4.	Kot Kehloor	98050-81694, 01978-207031
5.	Sadar Bilaspur	98161-95702, 01978-222588
6.	Swarghat	94180-79051, 01978-284024
7.	Talai	94181-61999, 01978-264038
8.	I/C PP City	94180-77061, 01978-224288
9.	I/C PP	94180-30137, 01978-288092
10.	I/C PP Golthai	94184-55700, 01978-207012
11.	I/C PP Namhol	94188-05799, 01978-240032
12.	I/C PAR Jhandutta	94188-06503, 01978-211488
13.	I/C P.P. Sai.	94181-14793

13. Medical Facilities in Bilaspur District

Detailed list of resources available in terms of Primary Health Centers, Community Health Centers, Ayurvedic Hospitals, Contact no of respective hospitals, Number of doctors in each health centers, no. of hospital staff, no of beds available in each hospital, list of available resources (Stretcher, first aid kit, wheelchair, Oxygen cylinder with trolley, body trolley, X-ray machine etc.) and other list like detail of blood banks, no of laboratories & age of the building. GIS mapping also in progress to map the available resources in the district Bilaspur.

Medical Facilities in Bilaspur District

Sl. No.	Name of Block/ Tehsil	Name of Health Units	No. of Ambulance /other Vehicle	Staff Available			Maximum Capacity to Accommodate Patient	BMO/C MO Name	Contact No.
				Doctor	Nurse	Others			
1	Sadar	RH Bilaspur	4	19	34	43	270	Dr. V.K. Chaudhary (CMO)	94181-34502
		CHC Ghawandal	1	1	3	8	6	Dr. Vipul Thakur	98162-62944
		CHC Panjgain	1	3	5	9	12	Dr. Amit Banyal	88942-37274
		PHC Namhol	1	1	2	11	6	Dr. Mahinder Singh	83520-89150
		CHC Markand	1	2	4	5	6	Dr. Yogeshwari Ram Rav	94185-84342
		PHC Swarghat	1	1	1	7	6	Dr. Archana Sharma	98051-89111
2	Jhandutta	CHC Jhandutta	1	4	7	16	20	Dr. Arvind Tandan (BMO)	94184-94906
		CHC Berthin	1	1	6	7	12	Dr. Arvind Tandan	94184-94906

Sl. No.	Name of Block/ Tehsil	Name of Health Units	No. of Ambulance /other Vehicle	Staff Available			Maximum Capacity to Accommodate Patient	BMO/C MO Name	Contact No.
				Doctor	Nurse	Others			
		CHC Talai	1	1	5	3	6	Dr. Rajeev MBBS	78318-41280
		PHC Kalol	1	1	1	6	6	Dr. Kumar Roshan	72063-56330
3	Ghumarwin	CHC Ghumarwin	2	5	6	10	50	Dr. K K Sharma (BMO)	94181-14909
		CHC Bharari	1	4	5	14	20	Dr. Bhanu	94180-31055
		CHC Kuthera	1	2	4	11	6	Dr. Vikash	94180-76062
		CHC Harlog	1	1	3	14	6	Dr. Sunil Kumar	94189-65044

14. Institutional Structure at State Level

At the State level, the State Disaster Management Authority constituted under the chairmanship of the Chief Minister and has the responsibility of planning, policies, plans and guidelines for DM and coordinating their implementation for ensuring timely, effective and coordinated response to disasters. The Chief Secretary is the Chief Executive Officer of the SDMA. Besides, the SDMA has seven other members. The SDMA will, inter alia approve the State Plan in accordance with the guidelines laid down by the NDMA, approve DMPs prepared by the departments of the State Government, lay down guidelines to be followed by the departments of the Government of the State for the purpose of integration of measures for prevention of disasters and mitigation in their development plans and projects, coordinate the implementation of the State Plan, recommend provision of funds for mitigation, preparedness measures, review the developmental plans of the different Departments of the State to ensure the integration of prevention, preparedness and mitigation measures and review the measures being taken for mitigation, capacity building and preparedness by the departments. The State Authority shall lay down detailed guidelines for providing standards of relief to persons affected by disaster in the State.

The State Executive Committee (SEC) headed by the Chief Secretary and four other Secretaries as its members shall be there to assist the SDMA in the performance of its functions. The SEC will further provide necessary technical assistance or give advice to District Authorities and local authorities for carrying out their functions effectively, advise the State Government regarding all financial matters in relation to disaster management, examine the construction, in any local area in the State and, if it is of the opinion that the standards laid for such construction for the prevention of disaster is not being or has not been followed, may direct the District authority or the local authority, as the case may be, to take such action as may be necessary to secure compliance of such standards, lay down, review and update State level response plans and guidelines and ensure that the district level plans are prepared, reviewed and updated, ensure that communication systems are in order and the disaster management drills are carried out periodically. The SEC will also provide information to the NDMA relating to different aspects of DM.

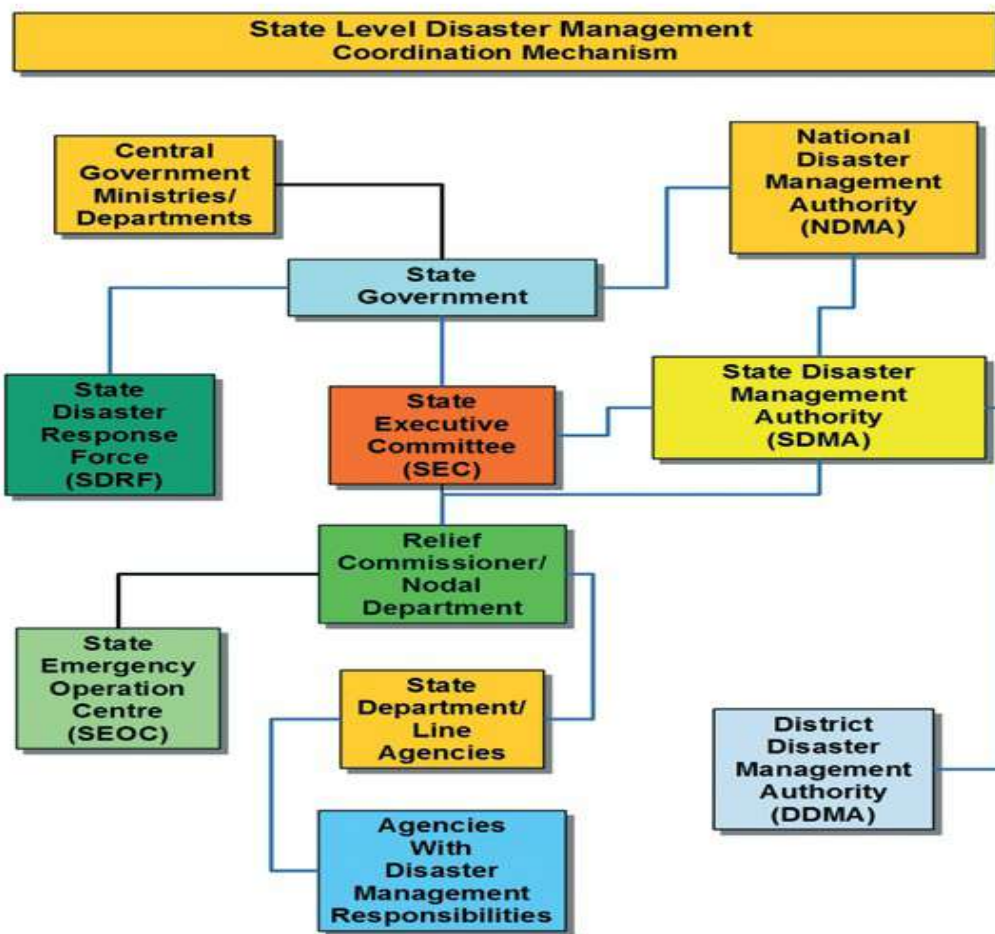

Fig 3: Institutional Arrangements for Disaster Management at State Level

15. State Disaster Management Authority

Members of State Disaster Management Authority

1.	Hon'ble Chief Minister	Chairman
2.	Hon'ble Revenue Minister	Member
3.	Chief Secretary	Chief Executive Officer, ex officio
4.	ACScumFC (Revenue)	Member
5.	Principal Secretary (Home)	Member
6.	Principal Secretary (PWD/I&PH)	Member
7.	Principal Secretary (Health)	Member
8.	Director General of Police	Member
9.	Secretary (Revenue)	Member Secretary

SDMA Roles and Responsibilities

As per Section (18) of Disaster Management Act 2005, SDMA has been designated by certain Roles and Responsibilities:

- Laying down policies and plans for disaster management within the State.

- Approve the disaster management plans prepared by the departments of the State Government.
- Lay down guidelines to be followed by the departments of the Government of the State for the purposes of integration of measures for prevention of disasters and mitigation in their development plans and projects and provide necessary technical assistance, therefore.
- Coordinate the implementation of the State Plan.
- Recommend provision of funds for mitigation and preparedness measures.
- Review the development plans of the different departments of the State and ensure that prevention and mitigation measures are integrated therein.
- Review the measures being taken for mitigation, capacity building and preparedness by the departments of the Government of the State and issue such guidelines as may be necessary

16. State Crisis Management Group

The crisis management group at State and districts level has been constituted for the State. The State Crisis Management Group (SCMG) is headed by the Chief Secretary. The SCMG shall normally handle all crisis situation and advice and guide the District Crisis Management Group (DCMG) also. The DCMG is headed by the District Magistrate and is responsible for on-scene management of the incident emergency.

The State Crisis Management Group's function are:

- To create a dedicated body that will assess, plan and implement the vital aspects of disaster management (Prevention, mitigation, preparedness and response).
- To ensure smooth coordination between Central and State Governments in the event of a disaster.
- To create a unified command, control and co-ordination structure for disaster management, integrating the various wings and agencies of government that are necessary for emergency response, as well as for preparedness, mitigation and prevention activities.

17. STATE EMERGENCY CONTROL ROOM / HIMACHAL PRADESH STATE DISASTER MANAGEMENT AUTHORITY

There is a State Emergency Control Room in the HP Secretariat, Chotta Shimla, Shimla, and Himachal Pradesh 171001 to provide Secretarial support to the Himachal Pradesh State Disaster Management Authority and facilitate the functioning of the Authority. 1070 is the Helpline Line No. of State Emergency Control room which is operational 24 x 7. This Control Room will receive the information from various sources. It shall be in constant contact with the District Disaster Control Rooms, Police Control Rooms. The State Emergency Control Room will receive the information, record it properly and put up to the State Disaster Management Authority instantly.

Similarly, the instructions passed by the State Authority shall be conveyed to the addressees and a record maintained to that effect. The Himachal Pradesh State Disaster Management Authority is involved in the Management of large-scale Disasters. The Divisional Commissioner in consultation with other members of the Authority shall decide its involvement after the receipt of the report from the Deputy Commissioner of the Districts. NDRF Battalion located at Nurpur, District Kangra, HP and Bhatinda, Punjab have been given the responsibility for deployment in Bilaspur, Himachal Pradesh. Contact Details of NDRF have been given in the district disaster management plan.

Water and Climate Related Disasters		
Floods	Department of IPH	IMD, CWC, ES&T
Hailstorm	Department of Agriculture and Horticulture	IMD, Home, insurance and Revenue
Cloud Burst	Department of I and PH	IMD, CWC, ES&T, Revenue

Heat and Cold Wave	Department of Revenue	IMD, ADMN, forest, Health
Snow Avalanches	Snow and Avalanche Study Establishment (SASE), Manali (DRDO)/Deptt. of Home/ES&T	Tribal Admin, IMD, Health, Home and Revenue, Mountaineering Institute/S&T/GSI
Droughts	Department of Agriculture/IPH	IMD, Revenue, RD, Nauni and Palampur universities/ Department of
Thunder and Lightning	Department of Revenue	IMD/ES&T
Geology Related Disasters		
Landslides and Mudflows	Geological Wing of Department of Industries, PWD, BRO & UD	GSI, CRRI, Ministry of Earth Sciences, Wadia Institute of Geology, Wadia Institute of Himalayan Geology
Earthquakes	Department of Environment, Science and Technology	IMD, Ministry of Earth Sciences/GSI
Chemical and industrial disaster		
Chemical and Industrial Disasters	Department of industries / Department of labour and employment	HPSEB, Department Of labour & employment, Home, Admn, DMI Bhopal, and NDRF
Accident-Related Disasters		
Forest Fires	Forest Department	Fire Department, ES&T, Home and Admn
Urban Fires	Department of Home (Fire)	IPH, Health, TCPI, Admn and Home
Major Building Collapse	Department of UD	PWD, Health, Home and Admn
Electrical Disasters and Fires	HPSEB/MPP and Power	Home, Health and Revenue

18. INSTITUTIONAL STRUCTURE AT DISTRICT LEVEL

At the district level, the Deputy Commissioner /District Magistrate will be the focal point for coordinating all activities relating to prevention, mitigation and preparedness apart from his existing responsibilities pertaining to response and relief.

19. District Level Mechanism in Bilaspur District

At District level, District Disaster Management Authority has been constituted under the notification of The Disaster Management Act 2005. The power of sanction of relief is also vested with the officials of revenue department at different level depending upon the need. The Deputy Commissioner/District Magistrate ensures participation of district and state government in the response and recovery phase.

20. District Disaster Management Authority (DDMA)

As per The Disaster Management Act 2005, each district has established a District Disaster Management Authority. The District Authority shall consist of the Chairperson and such number of other members, not exceeding seven, as may be prescribed by the State Government, and unless the rules otherwise provide, it shall consist of the following, namely:-

The DDMA for the district has been notified on 1.6.2007 as under:

1	Deputy Commissioner	Chairperson, ex officio
2	Elected Representative	Co-Chairperson, ex officio;
3	Superintendent of Police	Member
4	Chief Medical Officer	Member
5	Superintendent Engineer (I & PH)	Member
6	Superintendent Engineer (PWD)	Member
7	Chairman Zila Parishad	Member / Chief Executive Officer, ex officio
	Additional District Magistrate	

The District Authority shall act as the district planning; coordinating and implementing body for disaster management and take all measures for the purposes of disaster management in the district in accordance with the guidelines laid down by the National Authority and the State Authority and the roles and responsibilities of the DDMA have been elaborated in Section 30 of the DM Act, 2005.

DDMA Roles and Responsibilities

The roles and responsibilities of the DDMA have been elaborated in Section 30 of the DM Act, 2005. It will, internal perform the following roles and duties as per the act:

- Prepare, Coordinate and monitor a disaster management plan including district response plan for the district.
- Ensure that the areas in the district vulnerable to disasters are identified and measures for the prevention of disasters and the mitigation of its effects are undertaken by the departments of the Government at the district level as well as by the local authorities.
- Ensure that the guidelines for prevention of disasters, mitigation of its effects, preparedness and response measures as laid down by the National Authority and State Authority are followed by all the departments of Government at the district level and by the local authorities in the district.
- Review the state of capabilities for responding to any disaster or threatening disastrous situation in the district and give directions to the relevant departments or authorities for their up gradation as may be necessary.
- Organize and coordinate specialized training programmes for different levels of officers governmental and non-governmental organizations and voluntary rescue workers in the district.
- Set up, maintain, review and upgrade the mechanism for early warnings and dissemination of proper information to public.
- Ensure that the Departments of the Government at the district level and the local authorities prepare their response plans in accordance with the district response plan.
- Lay down guidelines for, or give direction to, the concerned Department of the Government at the district level or any other authorities within the local limits of the district to take measures to respond effectively to any threatening disaster situation or disaster.
- Advise, assist and coordinate the activities of the Departments of the Government at the district level, statutory bodies and other governmental and non-governmental organizations in the district engaged in the disaster management.
- Provide necessary technical assistance or give advice to the local authorities in the district for carrying out their functions.
- Review development plans prepared by the Departments of the Government at the district level, statutory authorities or local authorities

- Identify buildings and places which could, in the event of any threatening disaster situation or disaster, be used as relief centers or camps and make arrangements for water supply and sanitation in such buildings or places.
- Establish stockpiles of relief and rescue materials or ensure preparedness to make such materials available at a short notice.
- Ensure communication systems are in order, and disaster management drills are carried out periodically.
- Perform such other functions as the State Government or State Authority may assign to it or as it deems necessary for disaster management in the district.

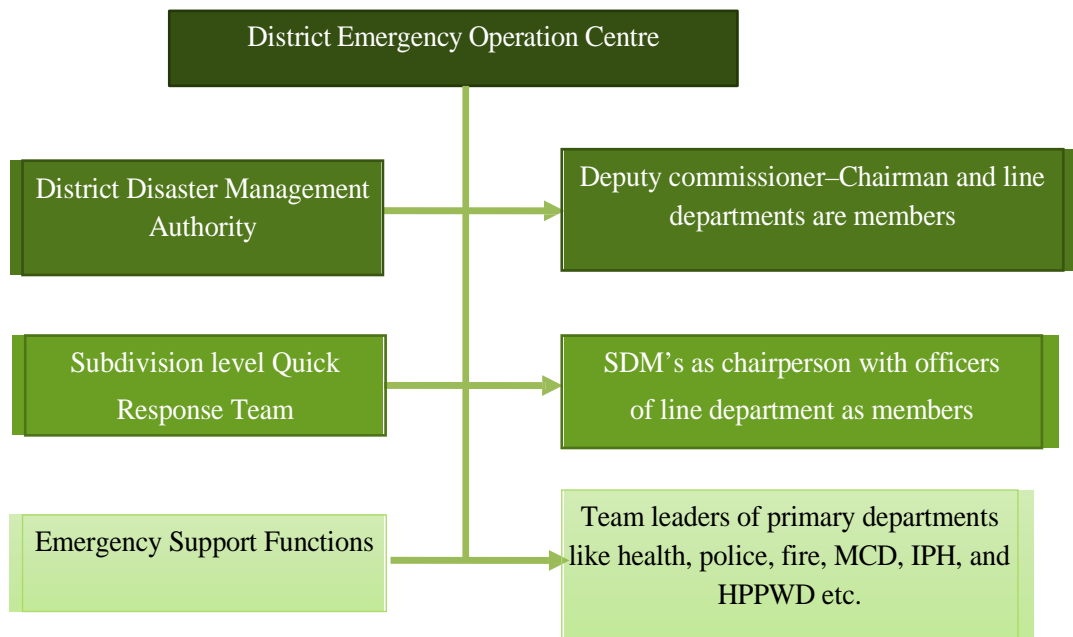

Fig 3.2: Institutional Arrangements at District Level

21. Subdivision level coordination mechanism

As per the institutional mechanism, Sub Divisional Magistrate (Civil) will call for the quarterly meeting the subdivision level disaster management committee to review the preparedness level and plan to reduce the gaps identified. The chairperson will further report the situation to the DDMA and send the requisition of resources if required.

22. Tehsil level coordination mechanism

As per the institutional mechanism, tehsildar will call for the quarterly meeting at the tehsil level disaster management committee to review the preparedness level and plan to reduce the gaps identified at Tehsil level.

23. Arrangements at local level

It is the local level that manages disasters within their own communities. Tehsil, subdivision and district levels are to provide additional resources, support, assistance and expertise as required. Local government is the key management agency for disaster events at local level. Local government achieves coordinated disaster management approach through Local Disaster Management committees.

24. Coordination system with inter departments and at District level

The District Magistrate/DC is the head of the district administrative set up and chairperson of the DDMA as per the DM Act, 2005. She / He has been designated as the responsible officer in the district. The heads

of different departments in the district will have separate roles to play depending on the nature and kind of disaster. The roles and responsibilities of the members of the DDMA will be decided in advance in consultation with the concerned members.

25. Pre-Disaster coordination

Minimum Annual meetings for review of preparedness and discussing the roles and responsibilities of the line departments, tehsils and Subdivisions. The meeting agenda would be discussing the capacity of each department in terms of SAR equipment's and manpower and regular updation of the same.

26. Disaster phase coordination

Coordination through phone or any other mode of communication in a disaster phase is not possible hence all the line departments and training institutes in the district should report to the DEOC as soon as the disaster strikes. After loss/damage assessment at the DEOC, the RO (D.C) would direct various stake holders to deploy their resources and task forces in the affected areas. Relief camps would be setup at a pre-defined location.

27. Post disaster coordination

In the post disaster phase, the RO would take updates on the conditions of basic amenities like water, food, roads, law and order etc. from the respective departments. An assessment of relief given and need of rehabilitation would also be taken in the post disaster phase.

28. Coordination mechanism with community

The community will be coordinated through the village disaster management committees. The mentioned committees generally comprise:

29. Frequency of local Committee meetings

Local Committee meetings must be held at least once in every six months at particular time and place decided by the chairperson of the group. In addition, the chairperson of a Local Committee must call a meeting if asked, in writing, to do so by:

- The District Authority for the Disaster district in which the Local Committee is situated; or
- At least one-half plus one of the members of the Local Committee.
- To help the Local government to prepare a local disaster management plan for its area.
- To identify and provide advice to the relevant District Authority about support services required by the Local Committee to facilitate disaster management and disaster operations in the area.
- To ensure the community is aware of ways of mitigating the adverse effects of an event and preparing for responding to and recovering from a disaster.
- To manage disaster operations in the area under policies and procedures decided by the district Authority.
- To provide reports and make recommendations to the relevant District Authority about matters relating to disaster operations.
- To identify and coordinate the use of resources that may be used for disaster operations in the area.
- To establish and review communication systems in the Local Committee, and with the relevant District Authority and other Local Committees in the situation of disaster.
- To ensure that information about a disaster in the area is promptly given to the relevant District Authority, and
- To ensure risk management and contingency arrangements of essential services within the Local government area. Further information about the functions of the Local Authority may be found under sections 41 of the DM Act 2005

30. Coordination mechanism with NGOs, CBOs, Self Help Groups (SHGs)

The strong linkages which NGOs CBOs have with grassroots communities can be effectively harnessed for creating greater public awareness on disaster risk and vulnerability, initiating appropriate strategies for strengthening the capacity of stakeholder groups to improve disaster preparedness, mitigation and improving the emergency response capacities of the stakeholders.

In addressing the emerging concerns of climate change adaptation and mitigation, NGOs can play a significant role in working with local communities and introducing innovative approaches based on the good practices followed in other countries.

NGOs can bring in the financial resources from bi-lateral and multilateral donors for implementing pragmatic and innovative approaches to deal with disaster risk and vulnerability, by effectively integrating and converging the various government programs, schemes and projects to create the required synergy in transforming the lives of at-risk communities.

The DDMA will maintain a proper record of the NGO's and CBO's working in the district and map the available resources for them. The DDMA will appoint a Nodal officer for coordination with NGO's, CBO's and SHG's. The DDMA will call annual meetings of NGO's, CBO's & SHG's for mapping their resources. The meeting will be coordinated by the designated Nodal officer.

31. Coordination with other districts and state

The DDMA will call annual meetings with neighboring district authorities pertaining to Disaster risk reduction and capacity building by reducing the existing gaps through regular coordination. The DDMA will participate in the meetings called by SDMA or other State level authorities to promote coordination with other districts and state authorities.

There shall be a Sub- Divisional Response Team at each Sub- Division. Composition of the SRT and its functions will be similar to the District Disaster Management Committee to the extent feasible. The Sub-Divisional Response Team shall consist of the following:

Members of Sub-Division Level - Disaster Management Committee

Sl. No.	Designation	Members
1.	SubDivisionalMagistrate	Chairman
2.	Block Medical Officer (Health)	Member
3.	SDPO	Member
4.	Executive Engineer, I & PH	Member
5.	Executive Engineer, HPPWD	Member
6.	Executive Engineer, (HPSEB)	Member
7.	Inspector, food Supply & Consumers	Member
8.	CDPO	Member
9.	BDOs	Member
10.	Divisional Forest officer	Member
11.	SDO (Telecommunication)	Member
12.	Tehsildar /Naib Tehsildar	Member

Non-official members:

- Pardhans Gram Panchayat / Pardhans Municipal Council / Nagar Panchayat.
- Re-preventatives of NGOs at Subdivision Level
- Elected representatives of the area

- Few prominent citizens.

All concerned Heads of the Departments shall intimate the Sub-Divisional Magistrate of each Sub-Division the name and the designation of their authorized representative and whenever there is any change of personnel. The Sub-Divisional Magistrate shall intimate the composition to the Deputy Commissioner / District Magistrate.

32. Tehsil Level Disaster Management Committee

Tehsil / Sub Tehsil level Disaster Management Committee headed by Tehsildar / Naib Tehsildar of the respective Tehsil/Sub Tehsil have been established in all Tehsils and Sub Tehsils of the District. The constitution of Tehsil / Sub Tehsil Level Committees is as under:

Members of Tehsil / Sub-Tehsil Level - Disaster Management Committee

Sl. No	Officer	Position
1.	Tehsildar/Naib Tehsildar	Chairman
2.	Medical Officer (Health)	Member
3.	SHO	Member
4.	Assistant Engineer, I & PH	Member
5.	Assistant Engineer, HPPWD	Member
6.	Assistant Engineer, (HPSEB)	Member
7.	Inspector, food Supply & Consumers Affairs	Member
8.	CDPO	Member
9.	Block Development Officer	Member
10.	Range Forest officer	Member
11.	Sub Divisional Officer (Telecommunication)	Member
12.	Office Kanungo	Member

33. Village Disaster Management Committee (VDMC)

VDMC taking into consideration disaster at grass root level would act locally supposed to report and take assistance with Block DM Committee. Consequently, Block DM Committee would acknowledge to District DM Committee. District DM Committee will facilitate to react accordingly below level committee and share the experiences and demand fund with State Disaster Management Committee. VDMC will make block disaster preparedness and mitigation plan. Each village shall have a Disaster Management Committee consisting of officials and non-officials. The Committee will be constituted to be overseen by the Gram Sabha. The Committee will broadly be responsible for awareness generation; Warning dissemination.

Community preparedness plan. Adopting safe housing practices, organizing and cooperating relief in post disaster situations. The members are:

Sl. No.	Detail	
1	Pradhan	Chairperson
2	Panchayat Secretary	Member
3	Principal (Education)	Member
4	Health Worker	Member
5	Anganwadi Worker	Member

Sl. No.	Detail	
6	President Union / Association	Member
7	Community Representative	Member
8	Community Representative	Member
9	Community Representative	Member
10	FairPriceShopHolder	Member

34. District Emergency Operation Centre (DEOC), Bilaspur

District Emergency Operation Centre (DEOC), Bilaspur has been established in Deputy Commissioner Office as per the directions received from Himachal Pradesh State Disaster Management Authority (HPSDMA), Shimla. The design, layout, equipment and operation of the DEOC, Bilaspur is as per the EOC Manual prepared at the State level. DEOC, Bilaspur has been equipped with all basic and advance communication and IT infrastructure e.g., EPBAX, Computers, LED sets, Telephone sets, Generator, emergency lights in ready-to-use mode. District Emergency Operation Centre (DEOC) has been established in DC office, Bilaspur and for the smooth running and functioning of DEOC round the clock (24x7) 08 professional have been hired.

Role of Emergency Operation Centre in Normal Time

The Deputy Commissioner of District Bilaspur is empowered to appoint an Administrative Officer as Officer-in-charge of EOC. He will be responsible for the effective functioning of the EOC. Responsibilities of the EOC in charge in normal time Include

- Ensure that all equipment in the EOC is in working condition.
- Collection data on routine basis from line departments for disaster management
- Develop status reports of preparedness and mitigation activities in the DDMP
- Ensure appropriate implementation of District Disaster Management Plan
- Maintenance of data bank with regular updating
- Activate the trigger mechanism on receipt of disaster warning / occurrence of disaster

Role of Emergency Operation Centre during Disaster

Based on the message received from the forecasting agencies, warning must be issued for the general public and the departments, which play a vital role during emergencies. Issuing correct and timely

warning would be one of the prime responsibilities of EOC. For effective dissemination of warning EOC should have a well-planned line of communication. The DC shall be the competent authority to disseminate a disaster warning. The warning on occurrence of a disaster will also be communicated to:

- All Emergency Support Functions
- Members of DDMC-Bilaspur
- Hospitals in the disaster area.
- Office of Divisional Commissioner
- State Relief Commissioner
- Emergency Operation Centre in the neighboring districts
- National / State Emergency Operation Centre
- People's representatives from the district

Apart from this the District Emergency Operation Centre must arrange desks for the Emergency Support Function in its complex for better coordination and help. Simultaneously the onsite EOCs are to be set up with the help of the district EOC. Further, the occurrence of the disaster would essentially bring into force the following:

- All district level staff from various departments, as required by the Collector, will be under the direction and control of the Responsible Officer. These would also include the district level staff.
 - Industrial Safety & Health | Health Department
 - Red Cross Society | Food & Supply | Police
 - Zila Parishad | Municipal Authorities | Public Health
 - PWD | Transport Department | Irrigation
 - Fire Department | Telecommunication
- The Responsible Officer may in case of large-scale disasters get in touch with the local Army / Navy
- / NDRF Battalion units for incidence response like rescue, evacuation and emergency relief measure.
- The Responsible Officer will have the authority to requisition resources, materials and equipment from private sector. The Responsible Officer will have power to direct the industry to activate their onsite plan and seek assistance, if required.
- The Responsible Officer will activate Response Plan with Operation Logistic and Planning Section desk arrangements and authorize establishment of transit and/or relief camps, feeding centers and cattle camps through Operation and Logistic Section.
- The Responsible Officer will send the Preliminary Information Report and Action Taken Report. In the event of possibilities of disaster in adjoining districts, including those beyond the state borders, the Responsible Officer will issue the alert warning to the concerned district authorities.

Forecasting and Early Warning Agencies

Early Warning System is the crux of disaster preparedness and response. Since, its objective is risk reduction by taking necessary precaution and action, earlier the warning is received, the better it is. For the EWS to be efficient and timely, it requires equally efficient backward linkages with instruments that become the basis for providing early warning. Apart from technological systems used for receiving early warning signal, community knowledge can also be utilized. The use of animal, birds and insects' behaviors for hazard early warning is being researched even in developed countries where their behavior is associated to possibility of occurrence of disasters. Such community knowledge may be used for issuing warning message too.

Emergency Warning and Dissemination

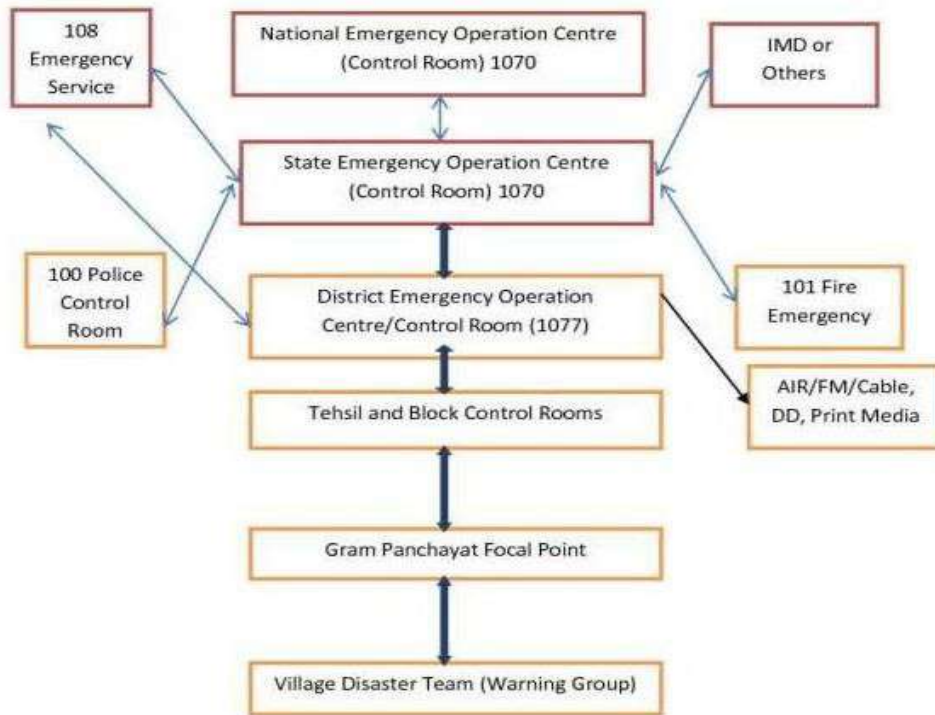

The EOC would utilize the ICT tools and various other modes available for early transmission of early warning to the vulnerable groups and activate the responders. The bulk group messaging services would also be utilized to alert the vulnerable groups and activate the SAR parties and all the responders. A model of early warning dissemination is given in figure above. The timely flow of early warning system from the source to the targeted stakeholder is important. The dissemination of early warning should be institutionalized so that it reaches the stakeholders in minimum possible time by recognized means of communication.

Following are the Nodal agencies in the Government of India and in the state mandated for early warning of different natural hazards prevailing in the state of Himachal Pradesh:

Sl. No.	Hazard	Nodal Agency with online web pages address	Contact Details
1	Floods	Central Water Commission of the Ministry of Water Resources, Shimla Zone http://india-water.gov.in/ffs/ http://www.india-water.gov.in/eSWIS-MapViewer/	0183-236105/ 0177-2624036, 0177-2624224 dirmashimlacwc@nic.in
2	Landslides	Geological Survey of India http://www.portal.gsi.gov.in/	0172-2622529 Fax. 0172-2621945. Mob: 09417371954. Joginder.singh@gsi.gov.in gsichd@sancharnet.in 1077
3	Earthquake	N- India Meteorological Department, http://www.imd.gov.in/pages/earthquake_prelim.php	N-011-24619943/ 24624588 / Dehradun
4	Hydro-meteorological	http://www.imd.gov.in/pages/main.php	0135-2525458,
5	Droughts	http://bhuvan-noeda.nrsc.gov.in/disaster/disaster/disaster.php	S-0177-2626211/0177-2629724/0177-2624976;
6	High Wind,	S- SDMA/SEOC	9816127668

Sl. No.	Hazard	Nodal Agency with online web pages address	Contact Details
	Hailstorm, Heat Wave, Cold Wave and High Rainfall	D- DDMA / DEOC	mm_sandhu@yahoo.co.in D-1077,
7	Forest Fire	Forest Survey of India, Dehradun http://www.weathershimla.gov.in/# http://fsi.nic.in/http://bhuvan-noeda.nrsc.gov.in/disaster/disaster/disaster.php?id=fire	(Fire) 01905-222900/ 101
8	Epidemics	Health and Family Welfare Department	CMO OFFICE: 1905 -222177 102 & 108 NAS
9	Human Induced Hazards Road accidents	Himachal Pradesh Police GVK-EMRI	100/ 8894918180
10	Dam / Reservoir Burst	D-Hydropower project,	01905-223282/ 1077,01907 01902-223282

Trigger Mechanism

As soon as Emergency Operation center would get the information about any emergency, the staff on duty in EOC will pass the information the DC / RDC and seek for his instruction for further actions. If the information pertains to the occurrence of a disaster in any part of the district, the staff on duty will also try to inform DDMA members, Emergency Support Functionaries-team leaders, major Hospitals and State Disaster Management Authority etc. The staff on duty will also be responsible to reclaim information related to type, magnitude and location of the disaster and inform it to responsible authorities. The EOC in-charge will also inform all the details to Divisional Commissioner and State EOC. All the desk officers / team leaders and Incident Command Team members will also be informed to immediately report at District EOC. Incident Command team and Desk officials would respond as per their standard operating procedures and directions of Incident Commander (IC).

Trigger Mechanism for District EOC

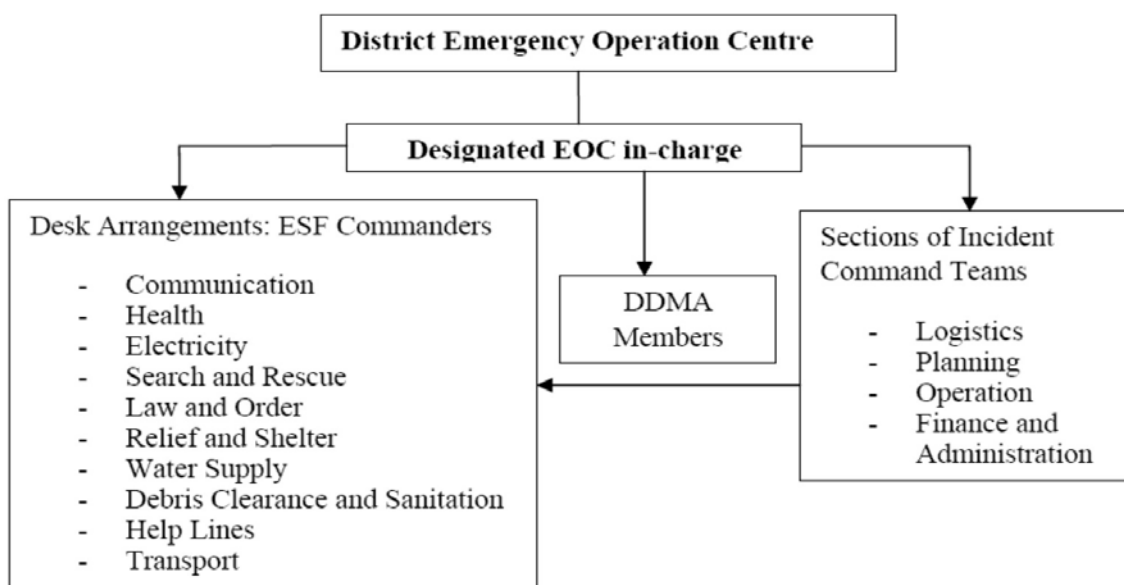

35. Incident Response System at Bilaspur District

The response structure would be based on Incident Response System (IRS) as per the Guidelines issued by the NDMA. IRS is a standardized method of managing disasters onsite, which is flexible and adaptable to suit any scale of natural as well as human induced disasters. It consists of common terminology, organizational flexibility, specialized training, unity, chain of command and well-rehearsed coordination mechanism. The IRS system would work through various service divisions. The IRS system would contract and expand depending upon the nature and magnitude of emergency / disaster.

At the district level, there will be one District Team with the primary function of assisting the deputy commissioner or in handling tasks like general co-ordination, distribution of relief materials, media management and the overall logistics. Suitable officers from the district administration will be carefully selected and professionally trained for the different IRS positions to constitute the District Level. The Incident Response System (IRS) at district level identifies and designates officers to perform various duties and get them trained in their respective roles; thus, reducing chaos and confusion during the response phase. It is a flexible system and all the Sections, Branches and Units need not be activated at the same time. Various Sections, Branches and Units need to be activated only as and when they are required. It also includes proper documentation of various activities for better planning, accountability and analysis which also helps new/ outside responders to immediately get a comprehensive picture of the situation and go in for immediate action. A sample IRT framework is given in figure; The DDMA would also form IRTs for all divisions and notify them. All the functionaries of IRT and IRS would be trained to understand the IRS system. The response structure would run parallel from district based on ESF plan (Annexure) for various departments.

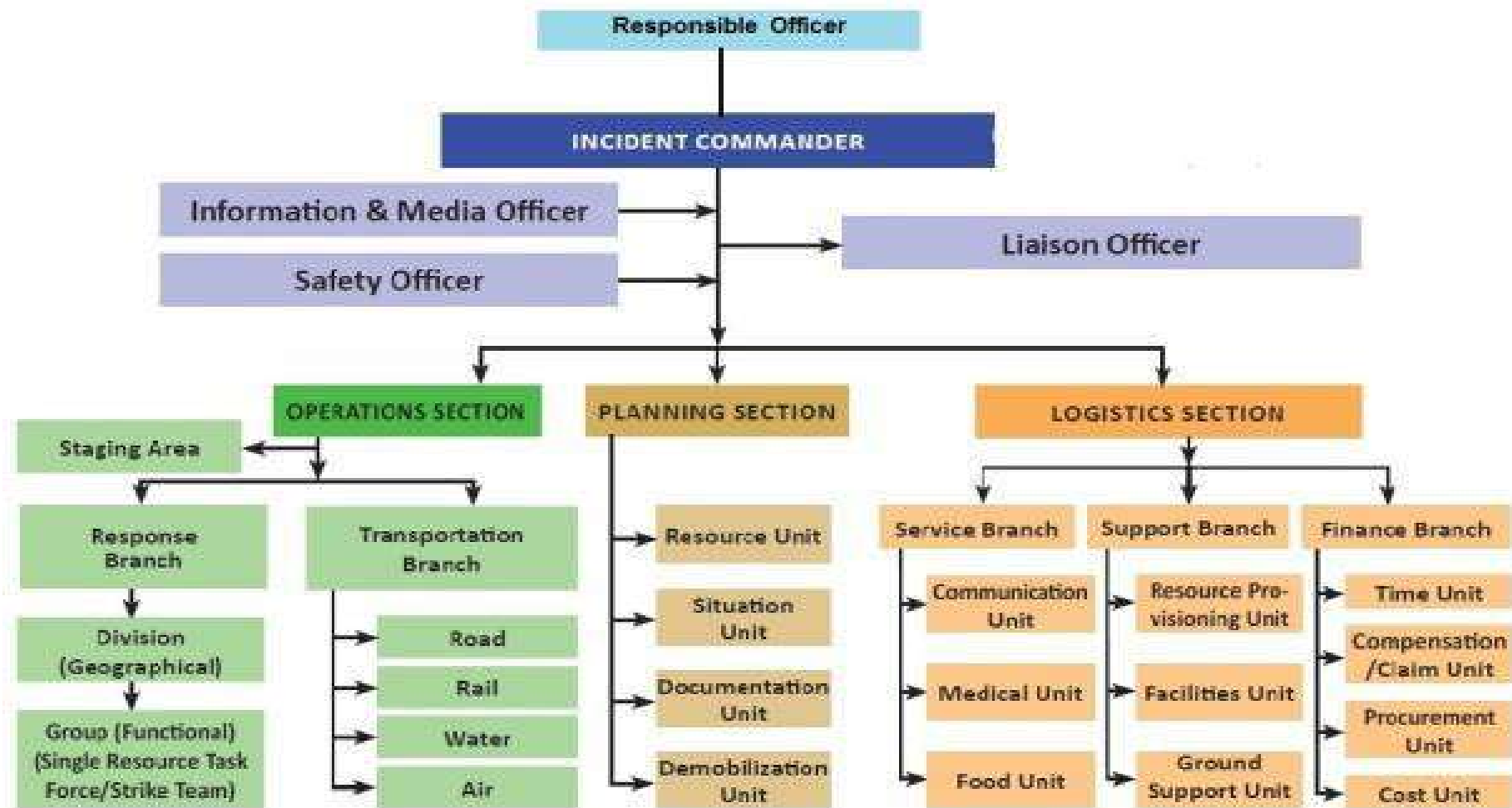

Outline of Responsibility of Main Functionary of Bilaspur district for IRS

Responsible Officer	Primarily responsible for effective response
Incident commander	Overall, In-charge of the Incident Response Team & its Effective Functioning.
Operations Sections	Direct & supervise all tactical actions.
Planning Sections	Collect/ Analyzedata, Workoutneed of requiredresources andprepare action plan for incident/Disasterof the Bilaspur district.
Logistics & Finance Section	Provide logistic support, procurement & cost accounting

IRS: On site Action during Disasters:

The following would be the broad guidelines for actions during disasters: -

- Assess the full extent of the disaster/calamity and the damages/losses incurred
- Plan and supervise search and rescue operations
- Allocate clear responsibilities to the officers and provide them necessary resources along with necessary delegations and Mobilize resources from outside the district if the situation so warrants.
- Finalize the relief to be provided to the affected persons and ensure its timely distribution
- Document the disaster including the lessons learnt Last but not least, keeping informing the higher authorities about the whole incident.

And all the above objectives can be achieved by Incident Response System (IRS) which is still in its infancy stag of implementation and training programs are conducted to have it streamlined in the existing administrative structure of the district.

**Disaster Management and Emergency Response
Plan at Project Road Level (to be prepared
separately for Project Road & Jetty Facility)**

DISASTER MANAGEMENT & EMERGENCY RESPONSE PLAN				At Project Road & Site Level
HIERARCHY ACTION IN CASE OF EMERGENCY				
Issued By	Checked By	Approved By	Date of Issue	Revision
Incident Controller/ Manager (Projects)	Site Controller/ GM (Projects)	CSC/ HPRIDC		0

IN CASE OF EMERGENCY PLEASE CONTACT



EXTERNAL AGENCY	
NAME	TELEPHONE NUMBER
Police	
Fire	
Ambulance	
Hospital(s)	
Dist. Collector Officer	
Any other agency	

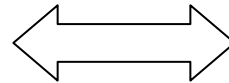

Name of the Contractor		
NAME	DESIGNATION	TELEPHONE NUMBER
	Project Manager/ Incident Controller	
	Site Controller / Emergency Controller	
	Safety In-charge / Assembly Area Coordinator	
	Security/ Watch ward	

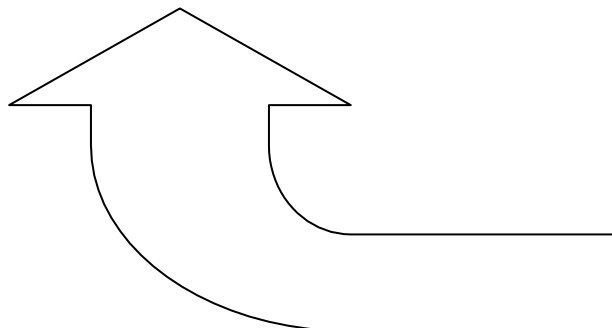

CLIENT - HPRIDC		
NAME	DESIGNATION	TEL. NUMBER
	Project Director, HPRIDC	
	Team Leader, CSC/ Resident Engineer, CSC	
	Executive Engineer. CMU	
	Environmental Specialist, HPRIDC	

Disaster Management Plan (DMP) & Emergency Preparation Plan of M/s..... (Name of the Contractor-Package Specific)

(Important Note: Needs to be updated/ prepared by the respective Contractor of the awarded package in consultation with District Disaster Management Authority, scrutinized & checked by CSC and approved by HPRIDC to be prepared separately for Project Road & Jetty Facility)

Background

The Disaster Management Act 2005 envisages disaster and its management as Disaster - Disaster means a catastrophe, mishap, calamity or grave occurrence in any area, arising from natural or manmade cause, or by accident or negligence which result in substantial loss of life or human suffering or damage to, or degradation of, environment, and is of such nature or magnitude as to be beyond the coping capacity of the community of the affected area.

Disaster Management Plan (DMP) and Emergency Preparedness Plan (EPP)

Disaster or Emergency and its Possibility

A disaster, and therefore an emergency, occurring as a result of a malfunction of the normal operating procedures or an intervention of an outside natural phenomenon force such as earthquake, floods, landslides, winds or sabotage, that may affect several sections within it and/or may cause serious injuries, loss of lives, extensive damage to property or serious disruption outside the works.

Apart from natural phenomenon, major fire and disruption, serious accidents may take place through explosion in Gas/Fuel Tankers, heavy leakage and subsequent fire in the oil tankers etc. near construction camp/ establishment sites.

Objective of Disaster Management Plan

In order to be in a state of readiness to face any accident or disaster caused during the project construction, a Disaster Management Plan shall be prepared. Such a plan ought to cover possible disaster, on and off-site emergency preparedness plan, establishment of Emergency Control Centers (ECC), location of emergency services, and duties of the officers/staff during emergency.

Basic Contents of DMP

Basically, the DMP shall contain the following aspects:

- Description of the Site
- On-site Emergency Plan
- Off-site Emergency Plan

Disaster Management - Disaster Management implies continuous and integrated process of planning, organizing, coordinating and implementing measures which are necessary as expedient for

- Prevention of danger or threat to any disaster.
- Mitigation or reduction of risk of any disaster or its severity or consequences.
- Capacity building.
- Preparedness to deal with any disaster.
- Prompt response to any threatening disaster situation or disaster.
- Assessing the severity of magnitude of effect of every disaster.
- Evacuation rescue & relief.
- Rehabilitation and reconstruction.

BASIC DEFINITIONS

1. **On-Site Plans** - address incidents originating at any of construction/ operation sites or establishment sites
2. **Off-Site Plans** - address incidents originating at any of construction/ operation sites or establishment sites outside but affecting the Project Work
3. **Risk** - The chance of an adverse event occurring in some period or in a specific circumstance, in the process of engaging in an activity
4. **Hazard** - A phenomenon which may cause disruption to persons and their infrastructure; and is an undesirable outcome in the process of engaging in an activity
5. **Disaster** - An event which can cause immense damage and disruption and causing loss to live of workforce and property.
6. **Emergency** - Serious sudden situation or occurrence that happens unexpectedly and demands immediate action to correct or to protect lives and/or property.
7. **Crisis** - Unstable situation of extreme danger. and may lead to the following elements: - Surprise- -Rapid flow of events-Lack of or insufficient information-Internal conflict-confusion
8. **Disaster Management** - Set of actions and processes designed to lessen disastrous effects before, during and after a disaster.
9. **Preparedness** - Measures undertaken in advance to ensure that individuals and agencies will be ready to react, such as emergency plans, logistical support and resource, inventories, and emergency information & communications systems
10. **Response** - Those measures undertaken immediately after a disastrous or hazardous event has occurred and for a limited period thereafter, primarily to save human life, property, treating the injured, prevent further injury and other forms of property loss and to mitigate disruption. They include response plan activation, declaration and communication of emergency to the concerned potential population and facilities at risk, opening and staffing of emergency operation centers, mobilization of resources, issuance of warnings and directions and provision of aid.
11. **Mitigation** - Those measures and activities aimed at reducing or eliminating hazards or lessening the impact of the event.
12. **Prevention** - Mitigation of hazard effects through public education, early warning or detection systems, safety systems, building and land- use codes and regulation.
13. **Recovery** - Those measures undertaken to restore normal conditions. The time frame for recovery begins as soon as a reduction in critical response activities permits the re-allocation of resources and could include physical restoration and reconstruction.
14. **All Clear** – Direction given by the incident coordinator (or authorized person) that the emergency has been revoked and that there is no further damage.
15. **Assembly Areas** – On decision of evacuation, the place where people will move first to assembly area where further instruction will be given.
16. **Suspect Device** – Any item that contains an explosive or mechanical device designated to explode by means of timer, touching, impact or by remote control a suspect device may appear suspicious by its placement, the circumstances surrounding its location or other information that may cause any person to become suspicious and decide that further

investigation is necessary.

Key Objectives of the Plan

- To build a safe and disaster resilient project construction sites by developing
- a holistic,
- proactive,
- multi-disaster oriented and
- technology driven strategy through
- prevention,
- mitigation,
- preparedness and
- response

Objective of Disaster Management Plan

- To improve state of preparedness to meet any contingency
- To reduce response time in organizing assistance by
- defining responsibilities,
- procedures for facilitating the curtailment and/ or restoration of Asset(s).
- To identify
- major resources,
- manpower, material & equipment needed to make the plan operational
- Making optimum use of resources.
- Closure of emergency, its analysis and identification of lessons learnt

Scope of Disaster Management Plan

- Landslides
- Floods
- earthquake
- Cloud burst
- Fire
- Terrorist Attack
- Any other hazard

Prevention of Disasters

Design the system after considering factors like:

- Highest flood level
- Seismic zones
- Wind zones
- Fire protection system
- Physical Security arrangements
- Other critical parameter

Disaster Management Cell at Contractor

- Management level at Contractor's Corporate Office
- Site level at respective project sites

Site level Disaster Management Committee

- Site Manager
- Site Engineers
- Safety In charge

Disaster Management at Site Level Responsibilities

- To maintain and update emergency call out list of persons:
- for emergency control,
- key personnel of Client
- fire safety
- first aid, medical emergencies
- Security, Police, District Administration Authorities
- Display communication details of nodal officers to be contacted in emergency
- Fixing of permanent notice boards at all suitable locations at project operation/ establishment sites displaying information, map, escape routes, precautions to be taken during emergency.
- To arrange food, drinking water, Tent for office space at site, accommodation for deployed employees/workers (all levels)

Appointment of Key Persons and their Role at Project Road/ Site Level

1. Site Controller (SC)

The General Manager (however called) or his nominated deputy will assume overall responsibility for the Site and its personnel.

2. Incident Controller (IC)

Project Manager or an Officer of similar rank will be nominated to act as the IC. Immediately on learning about an emergency, he will rush to the incident site and take overall charge and report to the SC.

3. Liaison Officer (LO)

Personnel/Administrative Manager or his nominated Officer of deputy rank will work as LO and will be stationed at the Nodal Control Centers during emergency to handle Police, District Administration, Hospitals and other enquiries.

4. Forward Area Controller (FAC)

Departmental In charge of the concerned area will be the FAC to take care of the respective departments during emergency.

5. Task Specific Team Leaders (TLs)

As number of specified activities may have to be carried out, for which specific teams have to be formulated and their roles or duties defined, each of them will be headed by a Team Leader, in accordance. The following teams are suggested:

- Task Force
- Repair Team
- Fire Fighting Team
- Communication Team
- Security Team
- Manpower Team

- Safety Team
- Transport Team
- Medical Team

Emergency Control Centers (ECC)

Emergency Control Room is to be set up and marked on the site plan for the knowledge of all concerned. ECC is the focal point and it should be well connected with internal and external telephones and furnished with list of personnel and their addresses.

Assembly Points

Assembly points, the pre-determined safe places, where people will be directed after evaluation from the hazardous locality, have to be set up and marked on the site plan. Escape routes from assembly points have to be clearly defined and depicted.

Alarms

Suitable sirens will be provided at Site, which could be operated from the Nodal Control Rooms. The coding of the siren should be as per the standards and well circulated within the facility.

Tie Ups for Aid with Institutions (Hospitals, Wards, Police Stations etc.)

It is essential to have mutual aid arrangements among the industries in the neighborhood which would help in the case of a major disaster.

Training and Mock Drills

Proper training of the key personnel and other non-key personnel, who will take part in case of an emergency, should be arranged through engagement of district level disaster management authorities. Mock drills shall be performed to test the performance of the procedure laid

Emergency Callout List

Sl. No.	Name of Official/ Agency	Mobile No.	Landline No.	Address
1	Site Manger			
2	Site Engineer			
3	Safety In charge			
4	Team Leader, CSC			
5	Resident Engineer, CSC			
6	Executive Engineer, CMU			
7	Environmental Specialist HPRIDC			
8	Project Director, HPRIDC			
9	Nearest Fire Station-I			
10	Nearest Fire Station-II			
11	Nearest Hospital-I			
12	Nearest Hospital-II			
13	Police Station			
14	District Magistrate			
15	Superintendent of Police			
16	District Disaster Management Cell			
17	State Disaster Management Cell			
18	National Disaster Management Cell			

APPENDIX 18: Illustrative Checklist for Work Zone Safety Requirements

Avoiding Collisions (Runovers & Backovers)

Safety & Health Checklist for the Roadway Construction Industry

How are most roadway construction workers killed?

Over 40% — nearly half — of the fatalities for roadway construction workers occur when workers are run over or struck by moving vehicles, trucks or equipment. Over half of the fatalities are caused by construction vehicles and equipment in the work area.

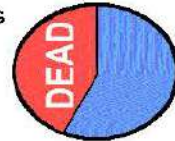

How can you avoid a "collision" in your work area?

Be seen. Make sure you wear high visibility clothing, including a vest and hard hat.



Communicate. If you are working near construction vehicles and equipment, make sure the operator/ driver knows where you are located. DO NOT assume he/she can see you.

Stay back. Do not approach moving equipment. Communicate with the driver using a radio, hand signals, etc. Only approach the vehicle once the operator has stopped operations.



Plan. Set up a plan or procedure — some call it an "internal traffic control plan" — to separate workers from the paths of vehicles and equipment. Make sure vehicles know where workers are located and workers know where equipment is operating.

Look out for other workers. Use a whistle, air-horn, or other device to warn fellow workers when they are in danger.



Positive Separation. Separate workers from traffic using "positive separation," such as barriers, road closures, shadow vehicles, and

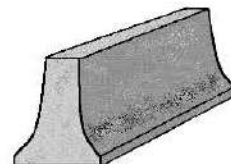

buffer space. Remember, this separation is important for BOTH roadway traffic and construction vehicles.

- ❑ **Be alert.** Don't become complacent with your work environment. Stay alert at all times and in all places. Stop, look, and listen for possible hazards.

Flaggers and directing traffic

Each year about 20 flaggers are killed and many more are injured. Flaggers must be especially vigilant to protect against collisions.



- ❑ **Get trained.** Don't accept an assignment to be a flagger unless you have been properly trained. You must know where to stand, how to dress, and how to properly communicate with motorists.
- ❑ **Wear high visibility clothing.** Know what type of clothing you should wear depending on the speed of traffic, the time of day, and the complexity of your surroundings.

- ❑ **Stay focused.** Keep your eyes on oncoming traffic. Make sure your signals are clear and do not conflict with other traffic control signals.



- ❑ **Plan an escape.** Plan a route so you can move quickly to safety if a motorist does not appear to heed your signals.
- ❑ **Warn fellow workers.** Make sure you have a way to quickly warn other workers when vehicles do not respond to your signals.
- ❑ **Respect motorists.** Be courteous. Do not respond to abusive drivers. Notify law enforcement if necessary.



This material was produced under grant number 46C3-HT31 from the Occupational Safety and Health Administration, U.S. Department of Labor. It does not necessarily reflect the views or policies of the U.S. Department of Labor, nor does mention of trade names, commercial products or organizations imply endorsement by the U.S. Government. The developers have not assumed any part of the employer's exclusive responsibility to provide a safe & healthful work place. **To find more information, please visit:** www.artba.org or <http://wzsafety.tamu.edu>.

Electrical Hazards

Safety & Health Checklist for the Roadway Construction Industry

What are volts, ohms, amps, and current?

- ❑ **Voltage** = force or pressure that causes electricity to flow through a conductor (wire). (Think of water held behind a dam.)
- ❑ **Ohm** = **resistance** that impedes the flow of electricity through a conductor. (Think of pipes. Pipe size restricts water flow.)
- ❑ **Amp** = measurement of **current** — the flow of electrons — from the source of voltage through a conductor. (Think of water moving through a pipe.)

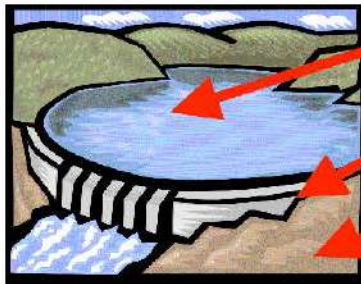

Voltage is like water in a reservoir. It's the measurement of electrical pressure.

Ohm is like water in a pipe. It's the measurement of electrical resistance.

Amp is like water moving through a pipe. It's the measurement of electrical movement or "current."

How much electricity will hurt me and how?

For death to occur, the body must become part of an electrical circuit. The actual amount of damage depends on the amount of current (amps), the pathway of electricity as it passes through the body, and the duration of the event.

Estimated Effects of AC Currents (U.S. Standard 60 Hz)	
1 milliamp (mA)	Barely perceptible
16 mA	Maximum current an average man can grasp and "let go"
20-30 mA	Paralysis of respiratory muscles
100 mA	Ventricular fibrillation threshold
2 Amps	Cardiac standstill and internal organ damage
15/20/30 Amps	Common U.S. household breakers



Check for these common sources of electrical energy exposure:

- Worn power cords (extension cords, hand tools)
- Water on or near electrical outlets, tools & cords
- Temporary circuit boxes and breakers for construction job sites
- Switches and connections on equipment, vehicles and machinery
- Buried utilities
- Overhead power lines

What are some precautions you can take to avoid contact with electrical energy:

- Contact appropriate "one call" number.
- Ensure buried utilities are marked by the proper authority.
- Locate and mark overhead power sources. Develop protocols for working near overhead power lines.
- De-energize, lockout and tagout power sources for equipment, tools and machinery before repairing or servicing.
- Use "ground fault circuit interrupters" (GFCIs) on all power tools and equipment that are not double-insulated.
- Inspect tools, cords, etc. to ensure they are in good condition before each use.
- Use appropriate personal protective equipment (PPE) including:
 - o Insulated gloves and footwear
 - o Non-metallic ladders

This material was produced under grant number 46C3-HT31 from the Occupational Safety and Health Administration, U.S. Department of Labor. It does not necessarily reflect the views or policies of the U.S. Department of Labor, nor does mention of trade names, commercial products or organizations imply endorsement by the U.S. Government. The developers have not assumed any part of the employer's exclusive responsibility to provide a safe & healthful work place. **To find more information, please visit:** www.artba.org or <http://wzsafety.tamu.edu>.

Mechanized Equipment

Safety & Health Checklist for the Roadway Construction Industry

What hazards are created by construction vehicles and equipment?

Construction vehicles and motorized equipment present a major hazard to highway construction workers. Recent studies indicate that workers are killed just as often by vehicles and equipment operating within the work zone as by motorists that cross the barricades and strike workers.

Construction vehicles and equipment can endanger:

- Drivers and operators
- Workers on foot
- Motorists/ public



To avoid roll-over hazards, DO NOT:

- Operate equipment too fast or on a steep grade
- Exceed the manufacturer's load or operating limits
- Use inadequate methods to load machinery onto a transport trailer
- Set, park or operate equipment on soft spots/soft shoulders
- Fail to use seatbelts, if equipped, to remain in position to control the vehicle



To avoid striking pedestrian workers with the vehicle, or its equipment — such as a bucket or shovel — check to ensure it has:

- Adequate brakes
- Functioning backup alarm
- Known blind spots (operators must check around their vehicle for workers before engaging)
- Proper barricades protecting the swing area of the equipment
- Continuous communication with pedestrian workers



Common hazards for equipment operators include striking utilities. Operators must have proper training and ensure adequate clearance. Construction vehicles and equipment can endanger workers by:

- Knocking down overhead wires or tree branches
- Making contact with power lines or buried utilities, causing the equipment to become energized
- Operating with an unguarded/ unbarricaded blade, swing radius and/or scissor points.



How can operators reduce hazards to themselves?

- Install and use rollover protective structures (ROPS)
- Install and use seat belts that meet the Society of Automotive Engineers (SAE) requirements
- Maintain a safe speed
- Use spotters for backing, loading, etc.
- Use ramps that are the right size and stable
- Use painted guidelines or other markings to guide operators and indicate hazardous areas



How can you prevent injuries to workers on foot?

- Inspect brakes and other stopping devices to ensure they are operating properly and able to stop and hold equipment when fully loaded
- Check to ensure backup alarms work and are louder than surrounding noise
- Use mirrors, closed circuit television, sensors and alarms or spotters to look for workers and hazards
- Make certain cab glass is not dirty, cracked or broken, and does not distort the operator's view
- Have operators check for other workers before starting the machine
- Warn workers when vehicles or equipment with rotating cabs are in use
- Guard scissor points, pinch points, and the swing radius of equipment when necessary

This material was produced under grant number 46C3-HT31 from the Occupational Safety and Health Administration, U.S. Department of Labor. It does not necessarily reflect the views or policies of the U.S. Department of Labor, nor does mention of trade names, commercial products or organizations imply endorsement by the U.S. Government. The developers have not assumed any part of the employer's exclusive responsibility to provide a safe & healthful work place. **To find more information, please visit:** www.artba.org or <http://wzsafety.tamu.edu>.

High Visibility Clothing

Safety & Health Checklist for the Roadway Construction Industry

What is "high visibility" clothing and when do you need it?

High visibility clothing refers to reflective and fluorescent vests, shirts, pants, hats, etc. that workers should wear to make them more visible when working near traffic and heavy equipment, in all light conditions, day and night.



You should wear high visibility clothing if:

- You work near traffic (on the side of a roadway, as a flagger, directing traffic, etc.).
- You work near moving construction vehicles and equipment such as large vehicles, dump trucks, pavers, graders, etc.

What type of clothing should you wear?

There are different classes of clothing, depending upon the hazards you are likely to face.

- Class 1 garments:** For workers that are separated from vehicular traffic that does not exceed 25 mph; where background settings and worker tasks are not complex.



- Class 2 garments:** Necessary for greater visibility during inclement weather; where work background is more complex and is close to moving traffic and vehicles; workers' attention will likely be diverted from traffic traveling at speeds from 25-50 mph.



- ❑ **Class 3 garments:** Traffic speed is greater than 50 mph; worker must be conspicuous — and identifiable as a person — through the full range of body motions at a minimum of 1,280 feet.

Is high visibility clothing hot and uncomfortable?

When the ANSI/ISEA 107 Standard for High Visibility Apparel was first developed, some of the early designs were hotter than what road-way construction workers were used to wearing.



Over the past few years, new designs have been developed, made of light-weight, breathable fabrics that are much cooler and can be comfortably used in hot and humid weather.

To obtain more information about the ANSI/ISEA 107 standard or to order a copy of High Visibility Apparel, contact the International Safety Equipment Association (ISEA) at www.safetysafetyequipment.org.

This material was produced under grant number 46C3-HT31 from the Occupational Safety and Health Administration, U.S. Department of Labor. It does not necessarily reflect the views or policies of the U.S. Department of Labor, nor does mention of trade names, commercial products or organizations imply endorsement by the U.S. Government. The developers have not assumed any part of the employer's exclusive responsibility to provide a safe & healthful work place. **To find more information, please visit:** www.artba.org or <http://wzsafety.tamu.edu>.

Multi-Employer Policy

Safety & Health Checklist for the Roadway Construction Industry

Are you covered by OSHA's Multi-Employer Policy?

You may be responsible for activities of other employers on the job site that expose workers to safety and health hazards.

Is there more than one employer / contractor on your site? If yes, then continue.

Did your company create and expose your workers OR the workers of another employer to hazards?

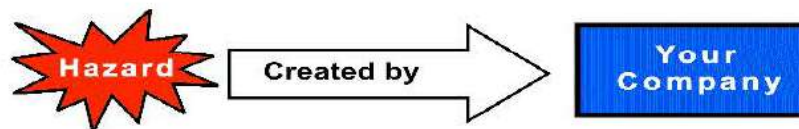

Is your company responsible, by contract or actual practice, for the safety and health conditions on a work site (even if none of your workers are exposed or your company did not create the hazard)?

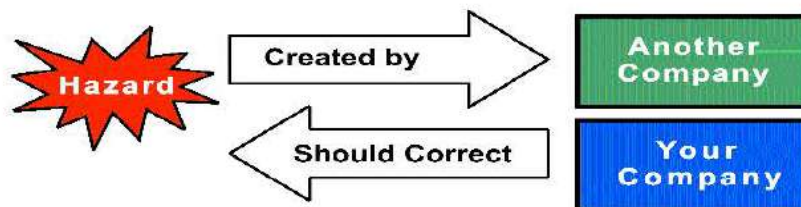

Does your company have the responsibility for actually correcting the hazard (even if none of your workers are exposed or your company did not create the hazard)?

Are your workers exposed to a hazard that was created by another employer?

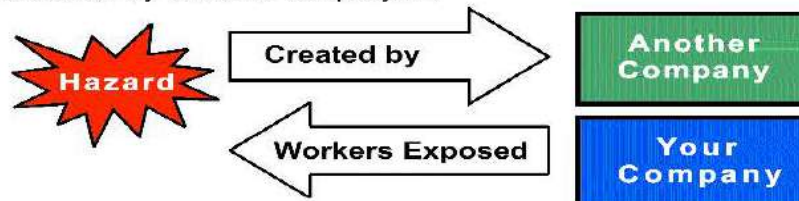

If you checked any of the boxes on the front, YOU MAY BE SUBJECT TO A CITATION FROM OSHA THROUGH THE MULTI-EMPLOYER POLICY.

Before OSHA issues a citation, it will consider the following issues that may reduce an employer's liability:

Did your company create the hazard?

Did your company have the responsibility or authority to correct the hazard?

Did your company have the ability to correct or remove the hazard?

Did your company notify the other responsible employers about the hazard to which their employees were exposed?

Did your company instruct its employees to recognize the hazard and 1) take steps to remove its employees from exposure, or 2) in extreme cases, remove its employees from the job?

What do you do when you find a hazard on your job site?

Correct or remove the hazard. If you are unable to do so, then:

Notify your workers and other employers of the hazard, and

Remove your workers from exposure to the hazard, or

Remove your workers from the job site.

NO MATTER WHAT OTHER EMPLOYERS OR WORKERS MAY DO, YOU ARE ULTIMATELY RESPONSIBLE FOR THE SAFETY AND HEALTH OF YOUR WORKERS.

This material was produced under grant number 46C3-HT31 from the Occupational Safety and Health Administration, U.S. Department of Labor. It does not necessarily reflect the views or policies of the U.S. Department of Labor, nor does mention of trade names, commercial products or organizations imply endorsement by the U.S. Government. The developers have not assumed any part of the employer's exclusive responsibility to provide a safe & healthful work place. **To find more information, please visit: www.artba.org or <http://wzsafety.tamu.edu>.**

Night Work

Safety & Health Checklist for the Roadway Construction Industry

What are some of the common problems identified with night work zones?

- Reduced visibility
- Driver impairment or inattention (drugs, alcohol)
- Fatigue, sleepy drivers
- Inadequate lighting
- Poor maintenance of traffic control devices



What are some of the solutions to the problems of night work?

- Have police officers present and visible
- Make workers more visible (better garments and lighting)
- Use drums in the taper
- Keep traffic control devices in good condition
- Provide adequate lighting
- Space traffic control devices closer together to reduce confusion — especially on ramps, crossovers, etc.



What can be done to reduce hazards for drivers?

- Use changeable message signs with up-to-date information.
- Obtain assistance from law enforcement. Ensure that all signs, markings, channelizing devices, and barricades are in good condition.
- Remove devices that are dirty, disfigured, or are not retroreflective.
- Use good quality temporary pavement markings. Cover or remove old, confusing markings.
- Increase the length of tapers to facilitate merges.
- Use transitional lighting to avoid temporary blindness from abrupt transitions from darkness to bright light and from bright light to darkness.
- Ensure that temporary work lighting does not glare in the eyes or mirrors of passing motorists.
- Move signage along with the work zone.

**ROAD WORK
AHEAD**



Does night work increase health problems?

Working at night makes it difficult to get enough sleep. Sleep after night work usually is shorter and less refreshing or satisfying than sleep during the normal nighttime hours.



Some research suggests that night workers have more upset stomachs, constipation, and stomach ulcers than day workers.

How can you protect your health and safety when working at night?

- Avoid permanent (fixed or non-rotating) night shifts.
- Keep consecutive night shifts to a minimum.
- Avoid quick shift changes.
- Plan some free weekends.
- Avoid several days of work followed by four to seven day "mini-vacations."
- Keep long work shifts and overtime to a minimum.
- Consider different lengths for shifts.
- Examine start-end times.
- Keep the schedule regular and predictable.
- Consider taking more frequent rest breaks.

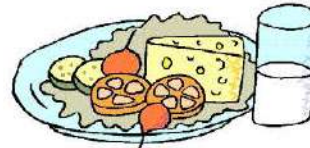

How can you maintain an active family and social life?

- Schedule activities on weekends or "off-days" to be with family and friends.
- Plan one meal a day when the family can eat together.
- Schedule "quiet" time during the day when you can get adequate, uninterrupted sleep.
- Don't participate in too many activities or other work that prevents you from getting adequate rest.
- Maintain a healthy diet and find time to exercise.



This material was produced under grant number 46C3-HT31 from the Occupational Safety and Health Administration, U.S. Department of Labor. It does not necessarily reflect the views or policies of the U.S. Department of Labor, nor does mention of trade names, commercial products or organizations imply endorsement by the U.S. Government. The developers have not assumed any part of the employer's exclusive responsibility to provide a safe & healthful work place. **To find more information, please visit:** www.artba.org or <http://wzsafety.tamu.edu>.

Personal Protective Equipment

Safety & Health Checklist for the Roadway Construction Industry

What is Personal Protective Equipment?

Hard hats, safety glasses, face shields, earplugs, fall arrest systems, safety-toed shoes, and respirators are all types of *personal protective equipment* or PPE.

In the roadway construction industry, there are many potential hazards you might face every day. Your use of PPE is very important to protect your safety, health, and even life.



Who should provide your PPE?

It is the employer's duty to make sure you have the necessary equipment to safely do your work. In some cases, if the PPE could likely be used away from work, you may be required to purchase your own. The items you may have to purchase are apparel such as safety-toed shoes, prescription safety glasses and outerwear.

What types of PPE should you use?

The best way to protect against hazards is to eliminate them, such as providing guardrails to prevent falls, or good ventilation to remove fumes and gases.

In roadway construction, these "engineered" hazard controls are not always feasible, so PPE must be worn to protect against the hazards to which you are exposed on any given task.

Here are some of the basics:

- Hard Hats** (head protection): Protect against electrical shock and impacts caused by falling objects or rocks thrown by passing vehicles. May provide for increased visibility near traffic and large vehicles.
- Safety Glasses** (eye and face protection): Protect against chemicals, particles, dust, and other airborne substances. Some safety glasses protect against the bright sun and provide UV protection for the eyes.



- ❑ **Gloves** (hand & arm protection): Protect against burns caused by electrical hazards, hot materials (asphalt), caustic materials (wet cement), and provide protection against cuts, punctures, blisters and skin irritation.

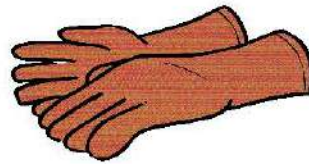

- ❑ **Ear plugs/muffs** (hearing protection): Protect against hearing loss that may occur suddenly, or gradually over time due to exposures to loud noises, such as heavy equipment or noisy hand tools.



- ❑ **Safety-toed shoes** (foot and leg protection): Provide protection against sharp, falling or rolling objects, hot materials, and slippery surfaces.

- ❑ **Harnesses and lanyards** (fall protection): Protect workers from falling. Required for exposures at six feet or higher, such as bridge construction, form work, overpasses, etc.



- ❑ **Respiratory protection** (dust mask / respirator): This type of protection can be a bit complicated, and will require competent personnel to determine what type of protection is needed and proper fit. You may need protection if you are working with or in proximity to:

- o dust containing silica (concrete & asphalt cutting, rock crushing, sand blasting)
- o metal fumes (from welding, brazing, soldering)
- o chemical fumes (motor fuels, cleaners, petroleum-based products)



To obtain more information about personal protective equipment, contact the International Safety Equipment Association (ISEA) at www.safetysite.org.

This material was produced under grant number 46C3-HT31 from the Occupational Safety and Health Administration, U.S. Department of Labor. It does not necessarily reflect the views or policies of the U.S. Department of Labor, nor does mention of trade names, commercial products or organizations imply endorsement by the U.S. Government. The developers have not assumed any part of the employer's exclusive responsibility to provide a safe & healthful work place. **To find more information, please visit: www.artba.org or <http://wzsafety.tamu.edu>.**

Temporary Traffic Control Zones

Safety & Health Checklist for the Roadway Construction Industry

What is a "Temporary Traffic Control Zone" or "Work Zone"?

A temporary traffic control zone, commonly known as a work zone, is the area on a roadway where construction work is taking place adjacent to traffic. Because of the constraints and locations of most work zones, they can pose many hazards for workers and motorists.

For definition purposes, a work zone has the following parts: 1) Advance Warning Area, 2) Transition Area, 3) Activity Area (Work Space, Traffic Space and Buffer Space), and 4) Termination Area.

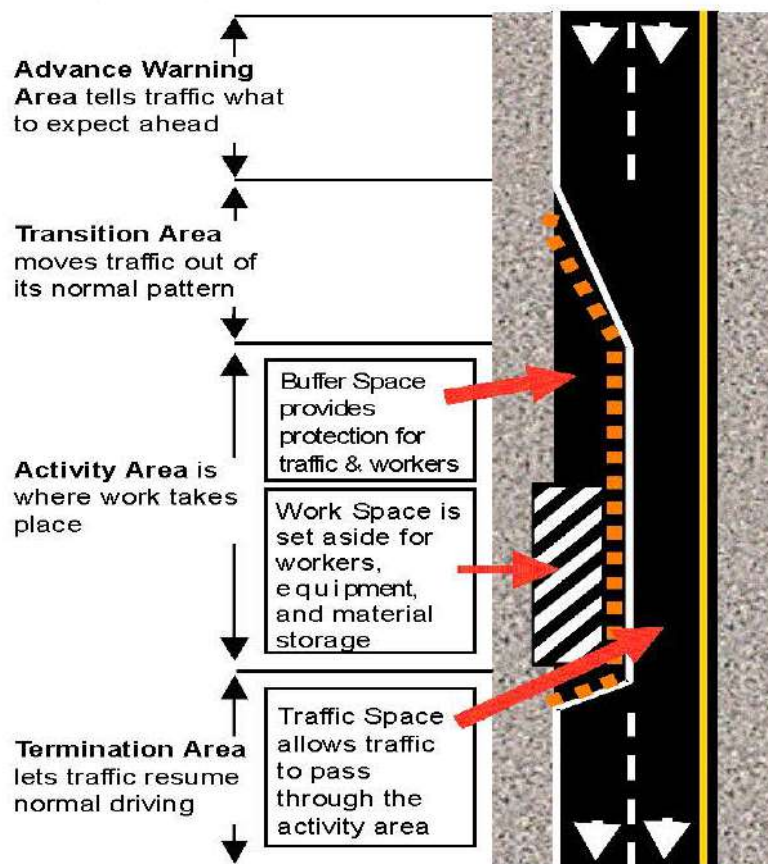

Review the following items to help you determine if your work zone is set up properly:

- Is the work zone set up as designed in the Traffic Control Plan? OR, if it is a small job where a traffic control plan was not developed . . .
- Are the traffic control devices (signs, markings, cones, barrels, etc.) set up as specified in the *Manual on Uniform Traffic Control Devices*?
- Are your signs in good condition? Do they maintain their "retroreflective" properties?
- Are your advance warning signs placed at the proper distances to adequately warn drivers?
- Are your channelizing devices (cones, barrels, barriers, etc.) placed properly, spaced at the proper distance according to traffic speeds?
- Are your channelizing devices in good condition? Do they maintain their "retroreflective" properties?
- Have old pavement markings been completely removed, and are new, clear temporary markings in place?
- Does your work zone traffic control require a flagger?
- Has your flagger been trained in a recognized program?
- Is your flagger attentive, always facing oncoming traffic, standing in the proper location, and using the correct signals/ paddle to direct traffic?
- Is your flagger properly dressed, with appropriate clothes to make him or her visible to traffic and construction vehicle operators?
- Does your flagger have a way to communicate with the other workers on the site?

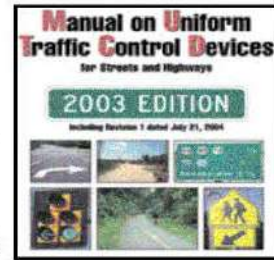

This material was produced under grant number 46C3-HT31 from the Occupational Safety and Health Administration, U.S. Department of Labor. It does not necessarily reflect the views or policies of the U.S. Department of Labor, nor does mention of trade names, commercial products or organizations imply endorsement by the U.S. Government. The developers have not assumed any part of the employer's exclusive responsibility to provide a safe & healthful work place. **To find more information, please visit:** www.artba.org or <http://wzsafety.tamu.edu>.